

# Essential Series Windows

## 1/2" Mull Reinforcement Instruction for Field Application

---

**ABSTRACT:** The following instructions are intended for use in assembling multiple wide and/or high configurations of Essential windows using field-applied mull kits. Please read through these instructions thoroughly and in their entirety before attempting to mull windows.

### IMPORTANT

More than one mull kit may be necessary. Field mulls beyond factory mulled configurations are not recommended. Maximum dimensions are 2W x 2H up to 96" x 96" R.O. or a 4W up to 114" x 78" R.O. Field mulled windows are not certified to the advertised DP ratings of individual windows.

---

*NOTE: Numbers listed in parentheses () are metric equivalents to the nearest whole number.*

### Mull Kit Parts

- 1 - Mull reinforcement (MRF)
- 2 - Mull bracket
- 2 - Mull plugs
- 4 - Rivets
- 1 - Sill mull bracket
- 2 - Flat sill structural brackets
- 6 - 90-degree bent structural brackets with 8-#7 x 5/8" screws
- 2 - Mull covers (interior and exterior)
- 2 - Nailing fin connector gaskets
- 2 - MRF T-Slot connections (for 1H mulls)
- 4 - MRF T-Slot connections (for 2+H mulls)
- 2 - #10 x 2-1/2" Spax screws
- 2 - Kerf weather strip

*NOTE: Inspect the mull kit to ensure that there are no damaged or missing parts. Parts listed above are included in each kit. More than one kit may be needed depending on configuration.*

### Tools and Supplies Needed

- Rubber mallet
- Rivet gun
- Caulking gun
- Hacksaw
- Silicone sealant and slip on nozzle
- Screw gun/drill with 7/32" drill bit
- Screwdriver with a #2 Phillips head bit
- Thin putty knife

### ⚠ CAUTION!

Always wear the proper eye and ear protection when using power tools. Follow all manufacturers' instructions for application and clean up of sealants.

---

# **WARNING!**

Drilling, sawing, sanding or machining wood products can expose you to wood dust, a substance known to the State of California to cause cancer. Avoid inhaling wood dust or use a dust mask or other safeguards for personal protection. For more information go to [www.P65Warnings.ca.gov/wood](http://www.P65Warnings.ca.gov/wood).

## ***Preparing the Windows for Mulling***

1. Remove and properly discard all shipping material.
2. Inspect the unit to make sure it is the right size, color, etc. and that there is no damage. If you find something wrong with your windows, contact your local Marvin representative and provide them with customer service number located in one of the corners of the glass. See [Figure 1](#).



**Figure 1**

3. Remove and set aside all screens and loose hardware.
4. Lay the units to be mullled on a flat sturdy surface exterior side up. Remove all nailing fin, if present, from windows at the mull and perpendicular to the mull. See [Figure 2](#).

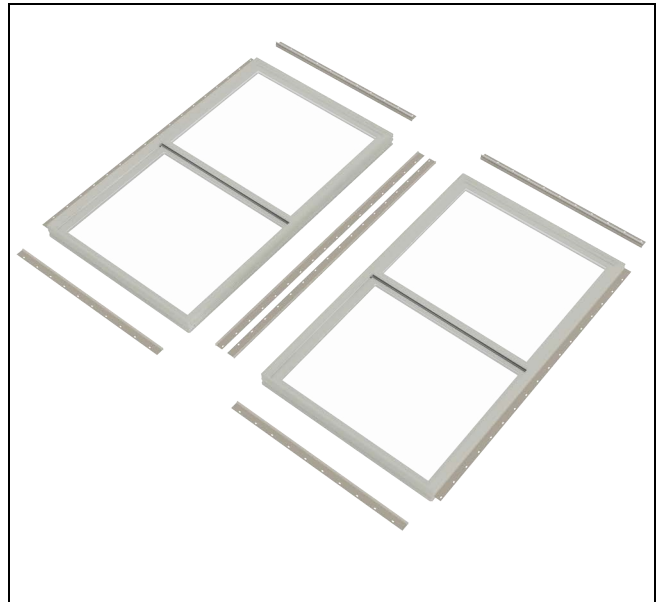

**Figure 2**

## Mulling the Windows

1. Set the units to be mulled close together and slide the mull T slot connector down the nailing fin channel on both units. If necessary pound the connector in with a rubber mallet or plastic hammer. See [Figure 3](#).

*NOTE: For 1-high units, insert 1 T-Slot Connector from the bottom. If the mull is 2-high or more, insert the second T-Slot Connector from the top.*

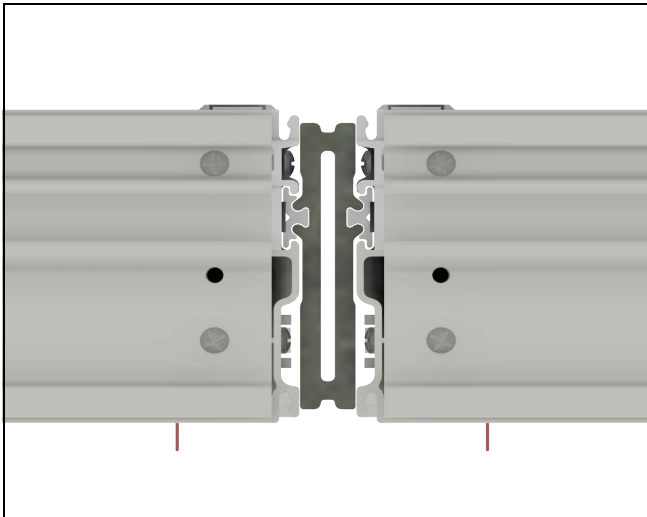

Figure 3

2. On all mull ends: Insert the mull plugs with the injection hole oriented toward the exterior. See [Figure 4](#).

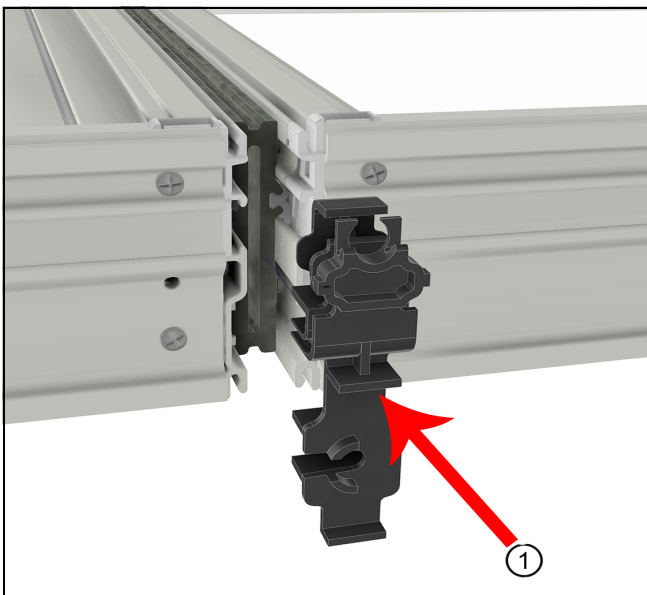

Figure 4 Line up mull plug with grooves in frame

1	Mull plug
---	-----------

3. Loosen the screws from the interior corners of the windows on both ends of the mull. See [Figure 5](#). (Remove screws from sill completely for sliding window products.)

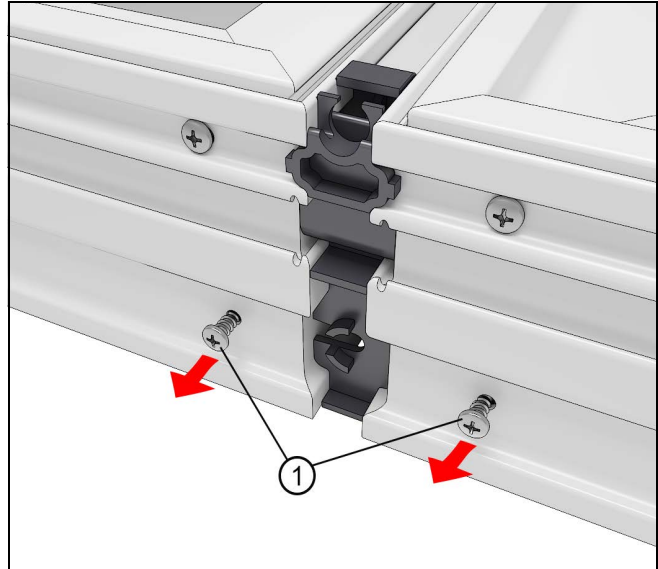

Figure 5

1	Loosen screws
---	---------------

4. Place the brackets as shown. Fasten using screws loosened in previous steps. See [Figure 6](#) and [Figure 7](#).



Figure 6 Head and jamb mulls

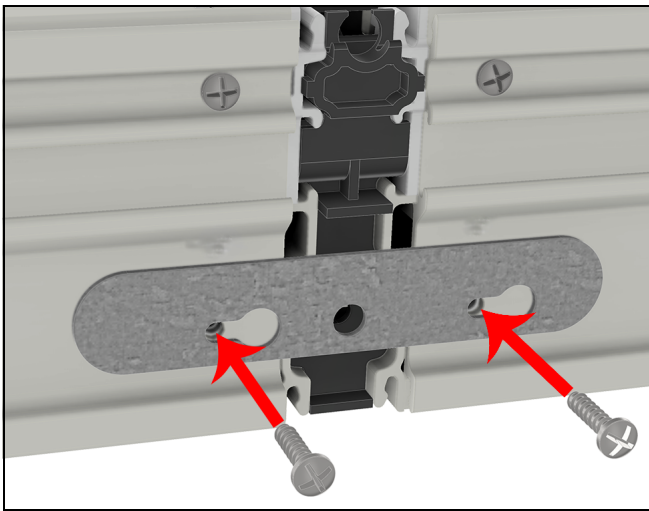

Figure 7 Sill only vertical mull

5. Using the 7/32" drill bit, drill through first layer of Ultrex using holes in end of bracket as a guide. See Figure 8.



Figure 8 Jamb/Head jamb mulls

6. Fasten all rivets. See Figure 9. (Sill mull brackets on sliding window products do not require rivets.)



Figure 9

7. Insert kerf weather strip into the accessory kerf on both sides along the full length of the mull. Apply 1" bead of silicone on top of kerf weather strip in the accessory kerf at mull ends. See Figure 10.

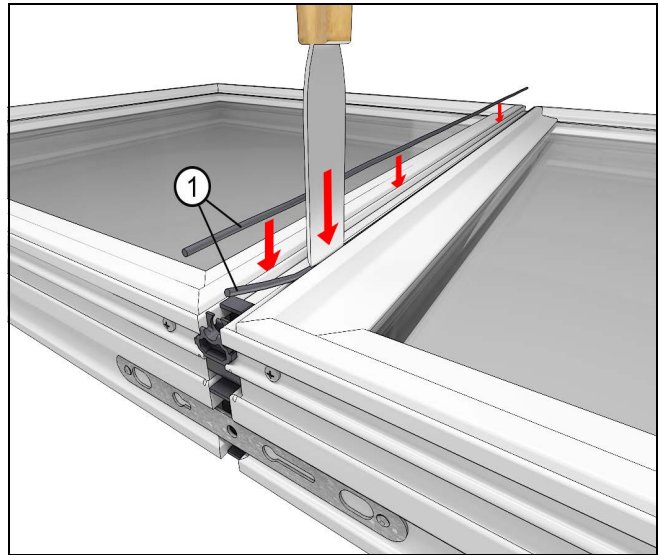

Figure 10

1	Kerf weather strip
---	--------------------

8. Install the exterior mull cover. These should be flush with the interior edge of the accessory kerf to allow for J-channel application. You may have to seat the cover with a rubber mallet or wood block and hammer. See Figure 11.

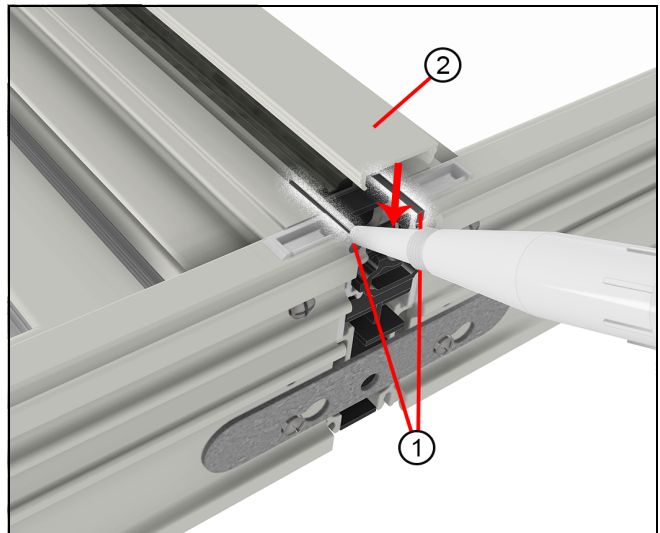

Figure 11

1	1" silicone bead
2	Mull cover



## Sealing the Assembly

**NOTE:** Be sure the sealant used is compatible with any flashing materials used to install the window into the rough opening.

- Using a high quality clear silicone sealant loaded into a caulking gun, insert the nozzle into the injection hole on the mull plug and inject with sealant. You will know there is enough sealant injection when overflow appears in the nailing fin channel below the injection hole and around the cover above the injection hole. See [Figure 12](#).

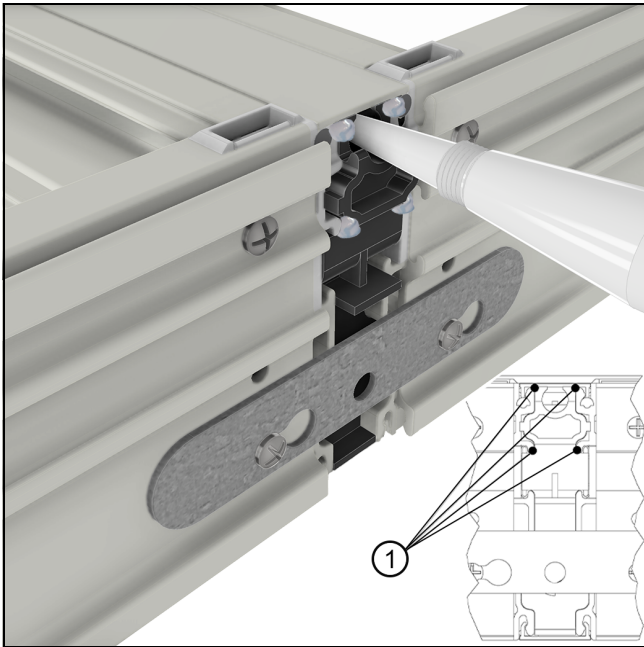

**Figure 12**

1	Squeeze out locations
---	-----------------------

- Flip the assembly over and install the interior mull cover using a rubber mallet, or wood block and hammer.

**NOTE:** Take care when handling or flipping the assembly.

- Install jamb and head jamb brackets. Place a bead of construction adhesive on either side of the mull within 1-1/8" from the center. Apply a 90° bent structural bracket in the same location, securing with 5/8" screws in outside holes. See [Figure 13](#). Apply a third bracket between the first two centered on the mull plug screw slot and fasten with a 2-1/2" Spax screw through the middle bracket hole into the mull pin.

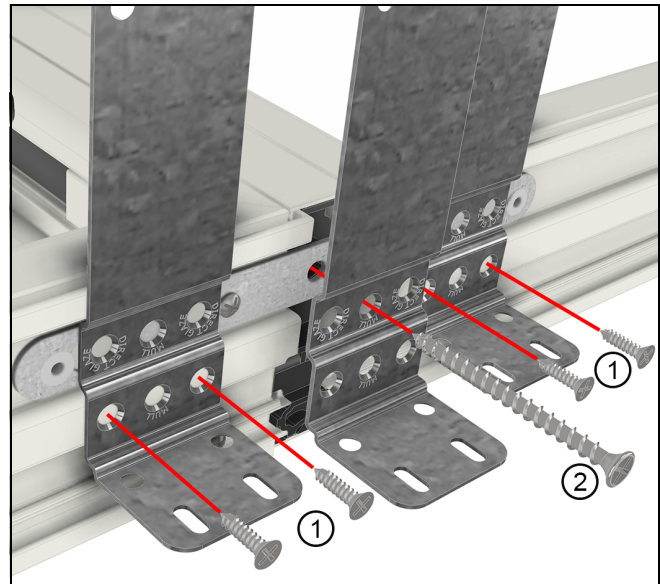

**Figure 13 Jamb and head jamb brackets**

1	90° bent structural bracket
2	2-1/2" Spax Screw

- For sill mull ends at the sill, apply two "flat" sill structural brackets spaced 1-1/8" from the center of the mull. Apply one 90° bent structural bracket between the first two, centered on the mull. See [Figure 14](#).

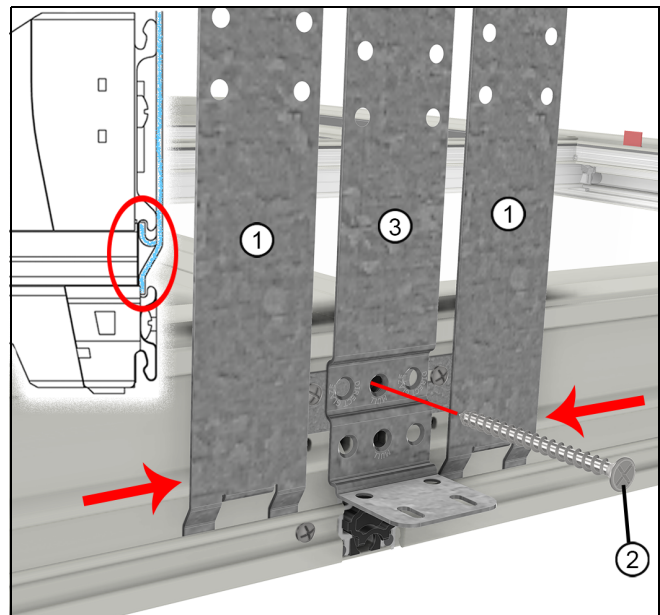

**Figure 14 Sill bracket placement**

1	Flat sill structural bracket
2	2-1/2" Spax Screw
3	90° bent structural bracket

5. Replace the nailing fin on the frame perpendicular to the mull. Leave sill nail fin off at this point. Slide the nailing fin in from the corners all the way until they butt up against each other over the mull plugs. Install the nail fin connector gaskets and seal around the edges of the connector. See [Figure 15](#) and [Figure 16](#).

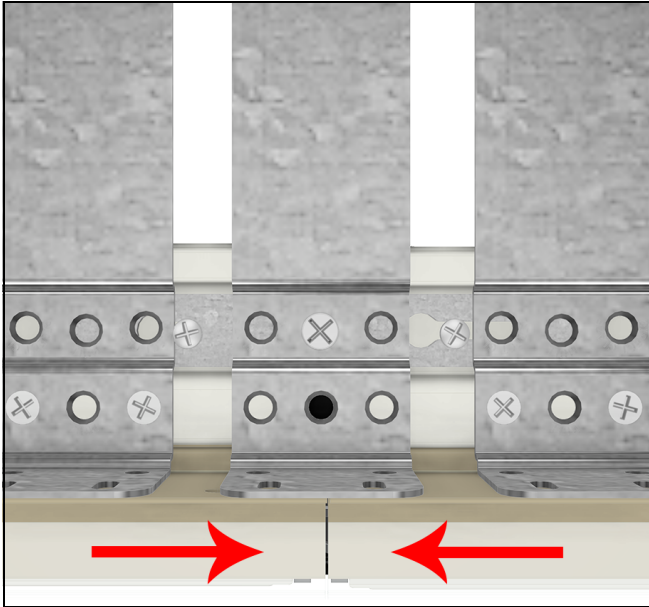

Figure 15

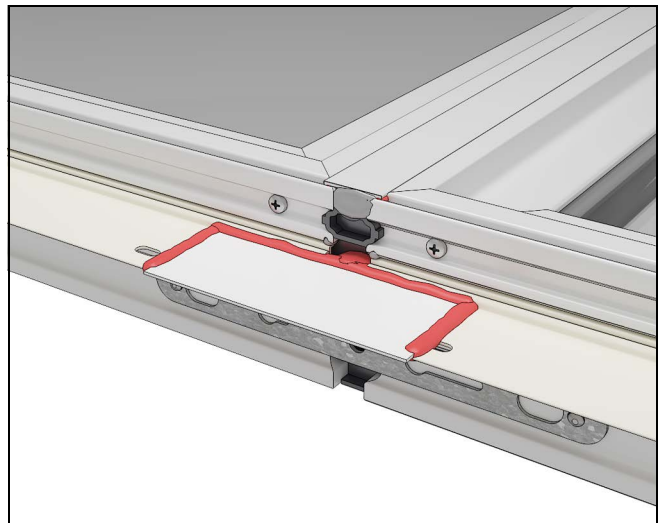

Figure 16

## 2W x 2H Configurations

*NOTE: When mulling All Ultrex windows in 2W X 2H configuration, you will need three mull kits.*

### IMPORTANT

Double Hung and Single Hung Operators cannot be mulled above other units.

*NOTE: Using the techniques outlined in the previous steps, prep, and mull the two vertical sections first (horizontal mulls). Then mull the two vertical sections together (vertical mull). Do not apply nailing fin until the entire assembly is complete.*

1. Ensure all mull plugs are injected.
2. Insert kerf weather strips. See [Figure 10](#) and [Figure 11](#) above. Then apply a 2" bead of silicone along the vertical accessory kerfs across the intersection. See [Figure 17](#).

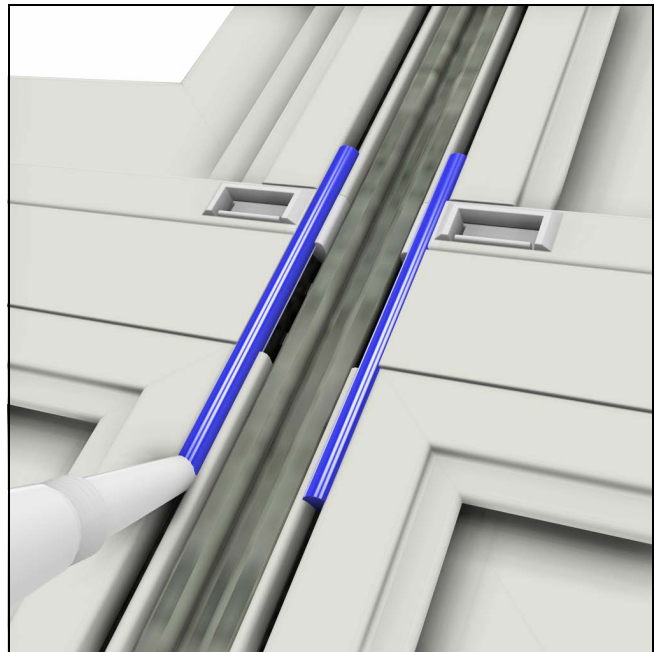

Figure 17

1	2" bead of silicone
---	---------------------

3. Ensure legs of accessory kerfs are cut away at the intersection to avoid damage to the mull covers. Cut out Ultrex accessory kerf walls to allow vertical mull cover to be fully seated. See [Figure 18](#). Seat cover with a rubber mallet or wood block and hammer. Make sure the joints are tight.

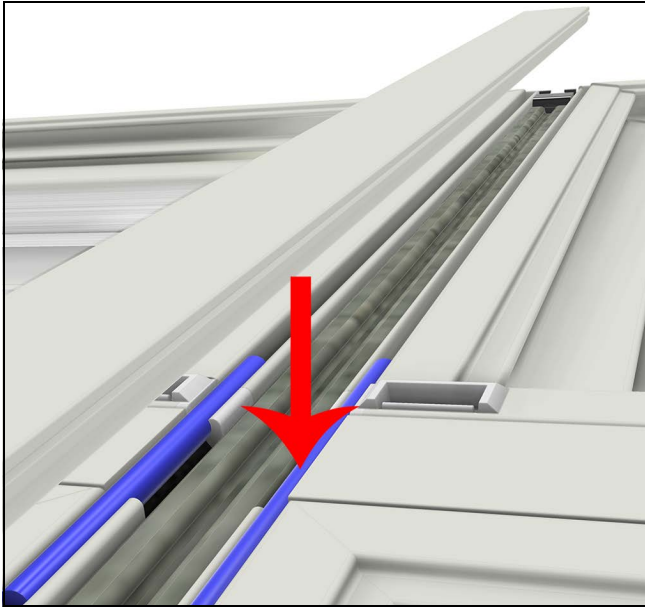

Figure 18 Vertical mull

4. Apply nailing fins, nailing fin connector gaskets, and 90° bent structural brackets on the jamb and head jamb mullion joints. See [Figure 19](#) and [Figure 20](#).

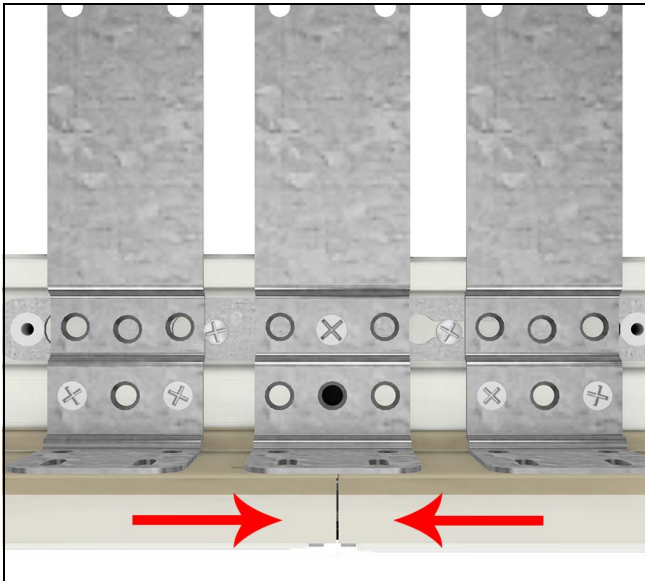

Figure 19

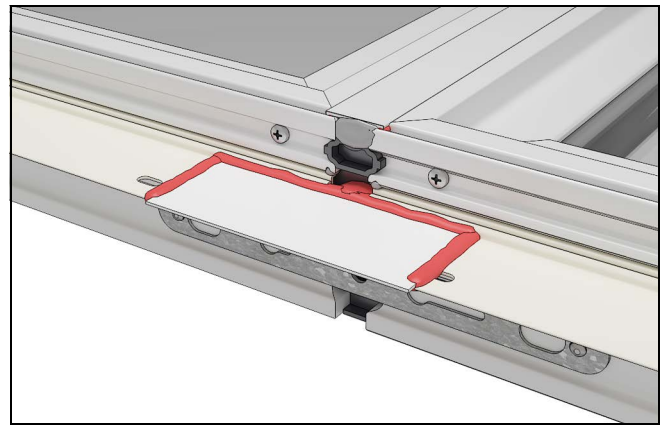

Figure 20

5. For sill mullion joints, take previously removed sill nail fin and cut sill nail fin at each mullion joint location and shorten the ends of each piece by 3"- 3-1/2" near each mullion to allow space for the flat sill structural brackets. Slide brackets and nail fin pieces into the sill T-slot. See [Figure 21](#).

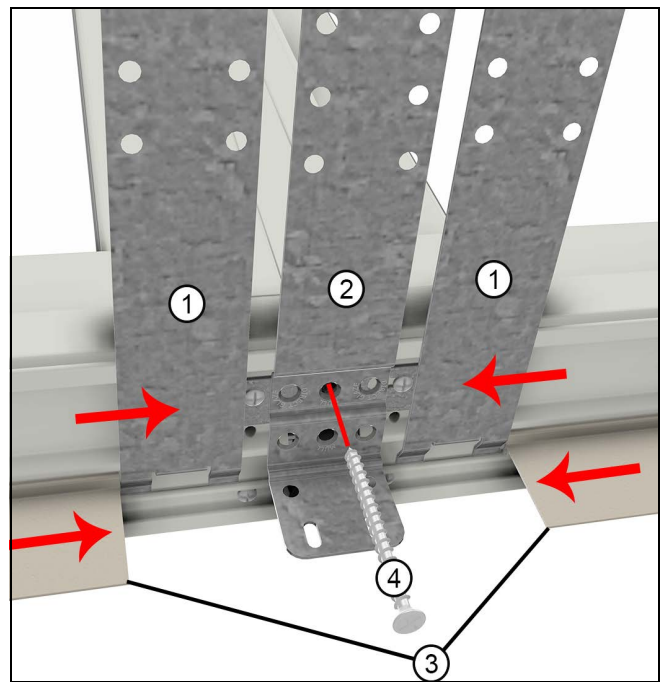

Figure 21 Sill bracket

1	Flat sill structural bracket
2	90° Bent structural brackets
3	Nailing fin
4	2-1/2" Spax screw into center hole of 90° bracket