

# Introduction and Product Performance (Ultimate)

How to Use this Manual .....	1
Top Level Abbreviations.....	2
Glossary of Terms .....	5
Unit Features on Windows and Doors.....	13
IZ3/IZ4: Code Requirements and Glazing.....	15
Egress Code: International Building Code - 2012, 2015, 2018 .....	16
Chain of Custody Certification.....	17
WDMA Hallmark Certification Program.....	19
Industry and Federal Performance Standards .....	20
Product Rating Codes / Performance Classes.....	21
STC and OITC Class Values.....	23
ENERGY STAR® Program - United States .....	27
ENERGY STAR® Most Efficient - United States .....	29
ENERGY STAR® Program - Canada .....	30
ENERGY STAR® Most Efficient - Canada .....	31
NFRC Certification Program.....	33
NFRC Label.....	34
Building Categories and Design Factors .....	35
Wind Speed Map - ASCE 7-16.....	38
Altitude Guidance .....	39



## How to Use this Manual

### Manual Objectives:

The content of this manual will aid in understanding the wide variety of standards, codes, and regulations governing the use of windows and doors. Consumer-friendly information on a variety of highly-rated Marvin Window and Door products along with fenestration standards, including glazing, clad finishes, hardware, and overall product performance can be used to help your clients understand what products best fit their project needs.

### Intended Audience:

**This manual is primarily intended for professionals who:**

- Provide shop drawings, sales and service to customers
- Write job specifications
- Need further product knowledge

### Sources of Additional Help:

- Marvin Architectural Hotline: 1-800-346-3363
- Our Website: [www.marvin.com](http://www.marvin.com)
- CSI Specifications
- Installations Instructions
- Warranty Information
- Care and Maintenance
- Owner's Manual
- Parts Manual

**The Online version of this document is the document of record and will be the most current version. Specifications and technical data are subject to change without notice.**

This manual is designed to make Marvin Windows and Door product knowledge easy to find and utilize. Used in conjunction with the Marvin Price Guide and Marvin Parts Manual, it will provide a library of Information on Marvin Products.

Each Window and Door Product has a collection chapter that covers general unit features. All individual chapters have product specific features. The line entries of the Table of Contents are linked to a specific page for assistance in locating necessary information.

### Product Notes:

- Numbers in parentheses () following measurements are metric equivalents in millimeters rounded to the nearest whole number
- Allow 1/16" (2) tolerance on all measurements
- For accessories, dimensions and applications, see the Accessories section of this manual
- All measurements for Rough Opening, Masonry Opening, Frame Size, Casing OM are rounded to the nearest 64<sup>th</sup> of an inch. Rounded Fraction for Glass Size, Daylight Opening, OM of Combination or Energy Panel, Storm Sash or RO Spring line are to the nearest 64<sup>th</sup> of an inch
- E = (Egress): Window that meets the requirements for Egress. Please note that the top of the sill must be no more than 44" (1118) from the floor. Code restrictions may vary depending on your local building codes
- T = (Tempered): For safety and/or code requirements, frame size greater than 71 1/8" (2924) tall, Marvin recommends tempered glass. Units with Frame 25.2 sq. ft. and larger may require tempered glass

### Trademark Information:

The following trademarks are referenced in this manual:

- E-Gard<sup>®</sup> is a registered trademark of Truth Hardware

### How to Submit Suggestions:

Comments or suggestions regarding this publication can be directed to: Technical Publications, Marvin Windows and Doors, P.O. Box 100, Warroad, MN 56763 or call (218) 386-1430 or 1-800-346-5044.

Top Level Abbreviations

**Marvin Product Abbreviations**

**General Term**

CN	Call Number
CNR	Corner Units
COMB	Combination
CR	Condensation Resistance
DLO	Daylight Opening
DP	Design Pressure
EP	Energy Panel
EXT	Exterior
EYE	Eyebrow
FCIR	Full Circle
FELP	Full Ellipse
FPAN	Flat Panel
FS	Frame Size
GOTH	Gothic Head
GS	Glass Size
GTH	Gothic
HCIR	Half Circle
HP	High Performance
IG	Insulating Glass
INACT	Inactive (X)
INST	Installed
LF	Lineal Feet
LH	Left Hand
LPS	Low Profile Sill
LT	Lite
MO	Masonry Opening
MPT	Multi-Point
MRF	Mull Reinforcement
OCT	Octagon
OSM	Outside Measurement
OPER	Operator (X)
PG	Performance Grade
PROJ	Projection
QCIR	Quarter Circle
QELP	Quarter Ellipse
QEYE	Quarter Eyebrow
RAD	Radius
RO	Rough Opening
RPAN	Raised Panel
SCR	Screen
SG	Single Glaze
SGL	Single
SHGC	Solar Heat Gain Coefficient
SL	Sidelite
SO	Sash Opening
SPEC	Special

SPLN	Springline
ST	Stationary (O)
TRDL	Traditional
VGR	Vertical Grain
VLТ	Visible Light Transmittance
W	Wood
W	Wide - Always preceded by number wide
WDW	Window

**Doors**

CBD	Combination Door
DRTR	Door Transom
SCD	Screen Door
SD	Swinging Door
SDDG	Swinging Door Direct Glaze
UIFD2.25 G2	Ultimate Inswing French Door 2 1/4" G2
UID	Ultimate Inswing Door
UIFDSL	Ultimate Inswing French Door Sidelite
UIFDTR	Ultimate Inswing French Door Transom
UOFD2.25 G2	2 1/4" Residential Outswing French G2
UOD	Ultimate Outswing Door
UOFDSL	Ultimate Outswing French Door Sidelite
UOFDTR	Ultimate Outswing French Door Transom
UIFD2.25AT	Ultimate Inswing French Door 2 1/4" Arch Top
UOFD2.25AT	Ultimate Outswing French Door 2 1/4" Arch Top
UIFDAT	Ultimate Inswing French Door Arch Top
UOFDAT	Ultimate Outswing French Door Arch Top
UWSPDINT	Ultimate Wood Sliding Patio Door Interior
USD	Ultimate Sliding Door
UWSFDINT	Ultimate Wood Sliding French Door Interior
USFD G2	Ultimate Sliding French Door G2
USFDTR	Ultimate Sliding French Door Transom
ULSD	Ultimate Lift and Slide Door
ULSD PKT	Ultimate Lift and Slide Pocket Door
ULSD STK	Ultimate Lift and Slide Stacked Door
UCD	Ultimate Commercial Door (1 3/4")
UCDTR	Ultimate Commercial Door Transom
UCDDGTR	Ultimate Commercial Door Direct Glaze Transom
UCD2.25	Ultimate Commercial Door 2 1/4inch
UMSD	Ultimate MultiSlide Door
UMSDSTK	Ultimate MultiSlide Door Stacked
UMSDPKT	Ultimate MultiSlide Door Pocket
UBFLD	Ultimate Bi-Fold Door



**Top Level Abbreviations****Clad Colors**

SW	Stone White
PB	Pebble Gray
SA	Sierra White
CO	Coconut Cream
CS	Cashmere
CG	Cadet Gray
BN	Bahama Brown
EG	Evergreen
HS	Hampton Sage
CC	Cascade Blue
BZ	Bronze
EB	Ebony
WB	Wineberry
MSL	Bright Silver (pearlescent)
MCP	Copper (pearlescent)
MLB	Liberty Bronze (pearlescent)
CY	Clay
GM	Gunmetal
SE	Suede

**Matching Paint and Stain: Options**

Color matching for trim or other detail work, we recommend reaching out to your customer service department or visiting your local Marvin dealer for a paint chip to color match at the hardware store or paint supplier of your choice.

## Glossary of Terms

**ALUMINUM SURROUND:** The aluminum frame around a screen or energy panel.

**APRON:** A piece of casing or decorative trim installed against the wall immediately beneath the stool of a window.

**ARGON GAS:** An inert gas known for its ability to provide insulating properties in IG air spaces.

**ASTRAGAL:** A moulding applied to one stile of a French Door, Sliding French Door or Ultimate French Casement window unit which the other door panel or window sash strikes. Usually head and foot bolt devices will be found on the astragal side.

**ASSEMBLY:** A collection of single units mullied together.

**AUTHENTIC DIVIDED LITE (ADL):** Also known as True Divided Lite. Permanent stationary muntins and bars separate the glass in a window sash or door panel to give the sash two or more lites of glass.

**AWNING WINDOW:** A combination of frame and sash, hinged at the top of the vertical jambs which allows the unit to pivot from the top with the sash opening to the exterior of the building.

**BALANCES:** Any system of block and tackle or spiral springs used in the jamb liner of double hung or single hung units to counter-weight the sash and allow for easier opening and top sash retention.

**BARs:** A narrow rabbeted, member in a divider system to create a series of divided lites in the daylight opening of the sash or panel. ADL, GBG, and SDL Spacer bars must be connected to the rails and stiles. SDL without spacer bars may be freely attached to the glass without contacting rail and stile. Bars can be assembled into a variety of patterns including grids, radius, diamond, Queen Anne, etc.

**BAY WINDOWS:** A series of windows installed in a “bay” which is two flanker units and a center sash; a “bay” may be an arc or a polygon; when a “bay” is or closely approaches an arc, the window is termed a “bow” See Bow Windows.

**BOW WINDOWS:** A series of adjoining window units, installed on a radius.

**BRICK MOULD CASING (BMC):** An exterior moulding of window and door frames that butts the exterior facing material of the structure. The casing serves as the boundary moulding for brick or other siding material and also helps to form a rabbet for screens and/or storm sash or a combination door.

**CAM LOCK:** A lever operated lock which is used to prevent intrusion through the sash. Cam locks and keepers were installed on the jambs and stiles of older Casement and awnings.

**CAM PIVOT:** A zinc pivot pin attached to the top and bottom sash stiles of double hung units (bottom sash on single hung units). Cam pivots rest on the clutch system of the balance tube assembly which allow opening and closing of the sash.

**CAPILLARY TUBES:** A tube inserted into the insulating glass spacer that allows the inside and outside air pressure to equalize in higher elevations. Capillary tubes will allow gas fills other than air to escape.

**CASEMENT WINDOW (CA):** A vertical hinged window system consisting of a frame, sash weather strip, locks, hinges and an operating crank device, on operating units. Push Out models are optionally available.

**CHECK RAIL:** The horizontal members of a double hung sash that are designed to mate with the check rail of the paired sash. These could also be vertical check stiles, as in the glider or patio door.

**CLAD (C):** Marvin clad products refer to wood window and door parts which are covered with an extruded permanent colored aluminum jacket on the exterior side of the frame and sash.

**CLAD BRICK MOULD CASING (BMC):** A clad extrusion designed to simulate brick mould casing for Marvin clad products.

**CLEAR OPENING (CO):** The opening created when the window or door is completely open.

**CLUTCH:** The plastic and metal assembly on which the cam pivots of a double hung or single hung sash rest. The clutch is attached to the balance system which allow opening and closing of the sash. The clutches are color coded for easy identification of balance strength.

**COMBINATION WINDOW:** A wood or clad wood frame storm sash with self-storing screen. Bottom glass panels such as those installed on a double hung unit operate by moving the plungers in and sliding the glass panel up to the desired position. Side glass panels such as those installed on gliders slide to the left or right to the desired position. All inserts are removable from the inside.

**COMMERCIAL DOOR:** A door which specifically targets the non-residential market and may not meet WDMA standards for water penetration. This door comes standard with an 1 3/8" (289) bottom rail and a 1/2" (13) low profile sill allowing it to meet ADA codes.

**CONDENSATION RESISTANCE (CR):** Measures the ability of a product to resist the formation of condensation on the interior surface of that product. The higher the CR rating the better it resists forming condensation.

**COTTAGE WINDOW:** A double or single hung window with the top sash smaller than the bottom sash.

**DAYLIGHT OPENING (DLO):** The width and the height of the visible glass.

## Glossary of Terms

**DEPTH OF THE JAMB:** The point where the exterior casing ends to the point where the interior casing begins. On clad units, the point from the backside of the nailing fins to the interior of the frame.

**DESIGN PRESSURE (DP):** Is a rating system that is based on testing for structural performance under static air pressure. Water leakage, air leakage, operating force and forced entry must also comply to attain a DP rating.

**DIRECT GLAZE (DG):** Refers to a stationary window with no sash where the glass is glazed directly into the frame.

**DIVIDED LITES:** See Authentic Divided Lites or Simulated Divided Lites.

**DOUBLE HUNG (DH):** A window unit with two movable sash which operate by sliding vertically. Double hung sash are retained in position with the use of balancing devices.

**DOUBLE HUNG MAGNUM (DHM):** Larger size Double hung windows. Double hung magnum windows have two movable sash which operate vertically. Double hung magnum sash are held in an open position with the use of balancing devices.

**DRIP CAP:** A formed aluminum or vinyl piece which is installed at the top of windows and doors that allows water to run off the casing of the unit instead of seeping around the casing and into the unit.

**DUAL GLAZE:** An IG with two panes of glass.

**EGRESS:** Refers to an escape opening in a room designated as a sleeping area. Windows and doors must meet a minimum size requirement to qualify as an egress product.

**ELECTRIC OPERATOR:** An electrically operated device which will open Casement or awnings units by using a switch. This is used in lieu of a roto gear crank or pole crank.

**EMISSIVITY:** A measure of a surface's ability to emit long-wave infrared radiation or room temperature radiant heat energy. Emissivity varies from 0 (no emitted infrared) to 1 (100% emitted infrared). The lower the emissivity, the lower the resultant U-Factor and the better insulating performance of the material.

**ENERGY PANEL (EP):** Formerly called an RDG - removable double glazing, is a piece of glass annealed or tempered, and finished on the edges by a surround. EPs are applied to windows or doors and rest on the glazing stop. EPs offer the homeowner added energy efficiency over single glazed units.

**ESCUTCHEON:** A decorative door handle plate attached to the stile directly behind the handle(s). Generally square or rectangular shaped.

**EXTRUSION:** A linear component of plastic or metal made by the process of heating the raw material and forcing it through a die as it cools to provide a specific cross-sectional shape.

**FENESTRATION:** Anything designed to fill an opening in a structure. Used in our industry to specifically apply to doors and windows.

**FINGER-JOINT:** A series of fingers machined into the ends of two pieces of lumber to be joined together. They are then held firmly in position by adhesive. Finger-jointed wood is very strong and has a lesser chance of warping than does a non finger-jointed piece of wood the same length.

**FLANKER:** A former term used to describe a side or lateral part. Also previously used to describe the side units in a 3-wide picture unit or bay. See two-wide entry.

**FLAT CASING:** Flat-surfaced on four sides, pieces of pine of various widths and thicknesses for trimming door and window openings. The casing serves as the boundary moulding for siding material and also helps to form a rabbet for screens and/or storm sash or combination doors.

**FOAM PLASTIC INSULATING SHEATHING (FPIS):** an insulating board

**FOOT BOLT:** A locking rod device installed vertically in the stile or astragal of a door or screen which when activated secures the panel or screen in a stationary position.



## Glossary of Terms

**FRAME:** The stationary portion of a window that encloses either the glass (direct glaze) or the sash (operating or stationary) and consists of the following parts:

1. **HEAD JAMB:** The top frame member.
2. **SILL:** The bottom frame member.
3. **SUB-SILL:** The supplemental member used under most awning and casement units as an additional sill with the primary purpose being to hold multiple units together at the sill.
4. **SIDE JAMB:** Side or vertical frame members.
5. **JAMB EXTENSION:** The addition onto the standard jamb to adapt a window unit to deeper wall thicknesses, in most cases will be factory applied unless specified otherwise.
6. **BRICK MOULD OR FLAT CASING:** The exterior trim member applied to the side jambs and head jamb on wood units. Often used to secure the window to the wall opening.
7. **BLIND STOP:** The frame member on a double hung window located between the jambs and the casing. The blind stop forms a rabbet that supports either a storm sash or screen.

**FRAME EXPANDER:** A flat aluminum extrusion used in conjunction with the 90 degree frame expander to provide a flat casing appearance for clad units.

**FRENCH DOOR:** A glass door consisting of moderate width top rail and stiles with a larger bottom rail. Doors available in either in-swing or out-swing operation. Can be rectangular or arched style top.

**GLASS SIZE (GS):** The measurement of the actual glass, not the visible glass.

**GLAZING:** Installing glass into windows and doors.

1. **SINGLE GLASS -** Glazing with a single piece of glass.
2. **INSULATING GLASS -** two or more panes of glass separated by a spacer and hermetically sealed together with dead air space between the panes.

**GLAZING BEAD:** Strips of profiled wood or vinyl used to hold the glass in position in the sash. Wood glazing bead is attached to the rails and stiles of the sash using staples, small nails or vinyl barbs. A vinyl bead is held in place by extruded barbs positioned in the kerf. Aluminum caps may be used over the vinyl bead in some cases.

**GLAZING TAPE:** A two sided adhesive tape placed between the glass rabbet and the glass and/or the glazing bead and glass of some unit types.

**GLIDER (GL):** Horizontal operating units which have one or more sash that glide open and shut horizontally.

**HANDING:** A term used to describe the right or left hand operation of a window or door.

**HEAD BOLT:** A locking rod device installed vertically in the stile or astragal of a door or screen which when activated secures the door in a stationary position.

**HISTORICAL OR HISTORIC:** A term used to define a window or door product meeting the requirements of historical renovation standards.

**IG:** Insulating glass (see Glazing)

**INACTIVE PANEL (X):** Secondary operating door panel.

**DOUBLE HUNG INSERT:** A specially designed, made-to-order sash and frame unit that is used to replace existing double hung sash and hardware in an existing frame - without disturbing existing interior trim or exterior casing.

**INSTALLATION BRACKETS:** A factory installed or supplied metal strip with holes used with windows or doors to attach the unit in the rough opening in lieu of nailing through the casing, thus eliminating unsightly nail holes. Available as an option for all Marvin wood windows or door products.

**INSWING FRENCH DOOR (IFD):** A French Door with panels that swing to the inside. One, two, three and four panel units available as stationary or operating.

**INSULATING GLASS (IG):** A glass assembly with two or more panes of glass sealed with a perimeter spacer.

**INTERIOR CASING:** The casing trim used on the interior perimeter of the window or door. Generally supplied by others except in the case of round top casing which is a factory supplied option.

**JAMB EXTENSION:** A jamb-like member usually surfaced on four sides, which increases or extends the depth of the exterior or interior window or door frame. Common jamb depths are 4 9/16" (116), 4 13/16" (122), 5 1/16" (129), 5 3/16" (132), and 6 9/16" (167).

**JAMB LINER (wood):** A strip of wood that goes on the inside of a window frame to provide a snug fit and finished look to the window. The birds' beak jamb extension is added to this piece to accommodate various wall thicknesses.

## Glossary of Terms

**KEYED CYLINDER LOCK:** A lock providing an exterior entry and locking convenience.

**LAMINATED GLASS:** Glass composed of two sheets of glass fused together with a sheet of transparent plastic between the sheets. When broken, laminated glass will generally not leave the opening and is often used as safety or security glazing.

**LAMINATED VENEER LUMBER (LVL):** An engineered wood product that uses multiple layers of thin wood assembled with adhesives. It offers several advantages over typical milled lumber: it is stronger, straighter, and more uniform. It is much less likely than conventional lumber to warp, twist, bow, or shrink due to its composite nature.

**LAMINATING:** A method of gluing strips of thin non finger-jointed wood to the lengthwise surfaces of finger-jointed material to provide the appearance of non finger-jointed stock.

**LEVER LOCK:** A lever handle and lever arm operator available as an option on awning units.

**LOCKSET:** A complete door lock system comprised of the lock mechanism together with knobs, keys, plates, strikes and other accessories.

**LOW E GLASS:** Low E stands for low emissivity. The lower the emissivity the higher the percentage of long wave radiation blocked thereby improving thermal performance. Low E glass is coated with a thin microscopic, virtually invisible, metal or metallic oxide layer. The primary function is to reduce the U-factor by suppressing radiative heat flow. A secondary feature is the blocking of short wave radiation to impede heat gain. There are two basic types of Low E glass. The first, vacuum or sputter coated Low E, is referred to as soft coat (See Low E2 definition). The second is pyrolytic Low E, commonly referred to as hard coat. (See pyrolytic definition.)

**LOW E1:** A high performance Low E coating, providing excellent balance for cold winters and warm summers. It offers increased solar heat gain coefficient values allowing heat from the winter sun to enter while reducing heat loss to the exterior. The Low E1 coated glass products are specifically designed for insulating glass units normally as a third surface coating.

**LOW E2:** A high performance Low E2 glass, providing excellent winter and center of glass temperatures. It offers reduced solar heat gain coefficient values providing customers cool summer glass temperature. Additionally, ultraviolet light transmission is greatly reduced. The Low E2 coated glass products are specifically designed for insulating glass units normally as a second surface coating. See Low E and pyrolytic definitions.

**LOW E3:** A high performance Low E glass, providing the best winter U-factor and center of glass temperatures. It offers extremely low solar heat gain coefficient values providing customers a summer glass temperature that is very low. Additionally, it provides the best reduction in ultraviolet light transmission.

**LOW ERS:** A hard coat Low E coating for the indoor IG surface, providing excellent heat reflectance. When used in conjunction with an E2 or E3 coating, it provides exceptional thermal properties – approaching that of a tripane unit with two LOW E coatings. The Low ERS coated glass reflects additional heat back to the room. The effectiveness of this coating causes the interior surface of the glass to cool and additional condensation may be noticed.

**LOW ELR:** A high performance Low E coating, providing the lowest Solar Heat Gain Coefficient with a slightly darker tint. It offers very good U-factor performance with excellent glare control. This product meets requirements for the “turtle code”. It provides the best reduction in ultraviolet light transmission.

**LOW PROFILE SILL:** Also referred to as saddles, these sills have no more than a 1/2" (13) rise. Low profile sills are required when a door opening must meet codes associated with the Americans with Disabilities Act.

**MAGNUM:** A Marvin trade name for heavily constructed window products which are designed for applications where a heavy duty product is necessary.

**MASONRY OPENING (MO):** A brick, stone or block opening into which a window or door unit is installed. Exterior casing may cause the Masonry Opening to be larger than the Rough Opening.

**MEETING STILES:** The vertical members of a glider sash or sliding door panel that are designed to mate with the meeting stile of the paired sash.

**MORTISE AND TENONING:** The system by which Marvin assembles authentic divided lite units, a projecting tenon on either the muntins or bars fit snugly into a mortise in either a bar, stile or rail.

## Glossary of Terms

**MULLING:** The act of attaching two or more window or door units together. The joint is then finished with a mullion center cap or mull trim.

**MULLION:** The vertical member of a sash, window or door frame between openings in a multiple opening frame.

1. **SPACE MULL** - Two or more units mull together with a space left between the units. The jamb extension surrounds the entire unit.
2. **STUD POCKET** - Two or more units mull together with a space between the units. The jamb extension surrounds each unit separately, providing space for a support member between the units.

**MULLION COVER:** A clad cover for space mull usage that covers a range from 3" (76) minimum to 10" (254) maximum width.

**MULLION EXPANDER:** An aluminum extrusion designed specifically for the Clad Magnum Double Hung Replacement System with Panning to allow the existing panning to be expanded to a wider width to accommodate a larger rough opening.

**MULLION REINFORCEMENT:** A system of high-strength members placed between units of an assembly and fastened to the RO and the units to provide enhanced structural performance. 3/8" (10) Aluminum, 1" (25) LVL, and various tube mullion options are available for most products.

**MULTI-POINT LOCKING SYSTEM:** A line of standard or optional multiple point locking mechanisms installed on the operative panel(s)/ sash of various Marvin products to enhance security and performance.

**MUNTINS OR "MUNT":** A short "bar," horizontal or vertical, extending from a bar to a stile or rail or another bar.

**NAILING FIN:** A factory installed vinyl strip that is inserted into a kerf in the frame of clad units. Nailing fin is designed to provide easier clad unit installation in new construction where the highest structural performance is not required.

**NON-KEYED LOCK:** A handle without a keyed cylinder. The door cannot be locked or unlocked from the exterior.

**OBSCURE GLASS:** (Pattern 62) A pattern glass that provided privacy while maintaining full light transmission. It is formed by running molten glass through special rollers that apply the pattern to one side.

**ORIEL WINDOW:** A double or single hung window with the bottom sash smaller than the top sash. (also know as 'Reverse Cottage')

**OUTSIDE MEASUREMENT (OM):** The measurement in width from outside of jamb to outside of jamb. Height measurement from top of jamb to bottom of sill. The outer edges of what is being measured.

**ONE WIDE (1W):** The current term used to describe one frame with single or multiple sash or panels.

**OPERATOR (X):** An operating sash, panel or unit.

**OUTSWING FRENCH DOOR (OFD):** A French door with panels that swing to the outside. One, two, three, or four panel units available as stationary or operating.

**OX and XO:** The letters OX or XO identify the operation of window or door units as viewed from the exterior. The letter O stands for stationary while the letter X stands for operating.

**PANEL:** An assembly of stiles and rails with glass that form the stationary or operating section of the door and is fitted in the frame.

**PANNING:** A term used to describe the aluminum covering extrusion components (i.e. jambs, sill and head jamb).

**PART STOP:** A strip of wood or aluminum with weather strip attached which prevents air and water infiltration. Part stops are commonly found at the head jamb of a double hung unit. Also referred to as a Blind Stop.

**PERFORMANCE CLASS:** A methodology to grade product performance types.

R = Residential, LC = Light Commercial, CW = Commercial, AW =Architectural

**PERFORMANCE GRADE (PG):** A numeric designator that defines performance that applies to; air leakage resistance, water penetration resistance and deflection resistance according to Standard Specifications.

**PITCH:** A term used to describe the angle of a roof. For example: A 4-12 pitch indicates that the roof rises 4" (102) vertically for each 12" (305) horizontally.

**POLE CRANK:** An extension pole used to open or close awnings or casements which would otherwise be inaccessible because of their height.

**POLYGON (POLY):** A high level term used to describe any shape with three or more straight sides. Typical fenestration shapes are triangles, trapezoids, pentagons, hexagons and octagons.

**PRIMER:** The first coat of paint in an application that is intended to prepare the surface for better adhesion by additional coats of paint.

**PULTRUSION:** Lineal profiles of constant cross section manufactured by combining plastic resin and continuous glass fiber reinforcement. These thermally insulating and structural components are ideally suited for applications where strength, thermal stability and weather resistance are required.

## Glossary of Terms

**RABBET:** A groove along or near the edge of a piece of wood.

**RADIUS:** The length of an imaginary line from the center point of a circle to the arc or circumference of a circle.

**RAILS:** The cross or horizontal members of the framework of a sash, door or other panel assembly.

**RELIEF KERF:** Kerfs machined into the frame parts of a unit. Relief kerfs inhibit warping.

**REMOVABLE MULLION:** A metal component available for two panel Commercial Doors. Anchored to the header and the sill, it separates the single opening into two, the mullion can be removed to allow furniture to be easily moved through the opening.

**RETRO:** Retro sizing refers to units which are sized for replacement purposes.

**RIM DEVICE:** May also be referred as panic hardware, a rim device spans the door panel. A push bar retracts the latch allowing for quick egress.

**ROLLED ALUMINUM:** A term used to describe aluminum profiles for screen and energy panel surrounds which are fabricated by the use of a roller or series of rollers to produce a desired profile. All other Marvin profiles are fashioned by the extrusion method.

**ROLLER CAM:** The adjustable roller devices of the Multi-Point hardware installed on the sash of the French Casement unit. When adjusted properly with an Allen wrench, they ensure a tight seal between the sash and frame members.

**ROSE:** A circular cover plate attached to the stile directly behind a knob or door handle. May be plain or have a decorative design embossed into the cover.

**ROTO-GEAR:** A term used to describe the steel drive worm, gears and crank device used for opening awning and casement windows.

**ROUGH OPENING (RO):** The opening in the wall where a window or door unit is to be installed. Openings are larger than the size of the unit to allow room for insulation, shimming and squaring of the unit.

**ROUND TOP (RT):** Any window unit with a radius frame member. The most common shape is a semicircle window with a horizontal sill which may be mulled to the top of another window or door. Round tops can be used separately or combined with other units to create a seemingly endless selection.

**SASH:** An assembly of stiles and rails with glass that form the stationary or operating section of the window and is fitted into the frame. Double Hung sash also contain check rails. The operating and/or stationary portion of the window unit that is separate from the frame. The sash consists of the following parts:

1. STILES - Vertical sash members.
2. RAILS - Horizontal sash members.
3. CHECK RAILS - Horizontal sash members that meet, as in double hung units. These could also be vertical check stiles, as in the glider or patio door.
4. BARS - Divisional members extending from rail to rail or from stile to stile in an authentic divided lite unit.
5. MUNTINS - Divisional members extending from a bar to a rail or stile or another bar.

**SASH LIMITER:** An optional metal device which attaches to an Ultimate Casement sill and bottom rail which limits the sash to a specified opening -5, 10, 15 or 20 degrees.

**SASH LOCK:** A device which holds a window shut and prohibits it from being opened from the outside.

**SASH OPENING (SO):** The opening between wood frame members for both height and width (disregarding any jamb hardware tracks). This measurement is used predominantly when measuring an opening for the Double Hung Tilt Pac.

**SASH RETAINER PLATE:** A flat plate used on double hung and Magnum Double Hung sash to secure the bottom sash.

**SASH WIDTH:** Horizontal measurement across the face of a sash.

**SCREEN OM (outside measurement):** The width and the height of a screen including wood or metal surrounds.

**SCREENS (full and half):** A close-mesh woven screen material of metal or fiberglass attached to an aluminum or wood surround. Screens inhibit entry of insects, yet permit light, air and vision. Most Marvin window and door products utilize full screens. Half-screens are available for single hung units.

**SEQUENTIAL LOCKING SYSTEM:** An exclusive Marvin design used on Ultimate Casement for locking the sash to the frame. The action is sequential where the lower lock activates first moving the sash to the weather strip; the top then engages to snug the sash to the frame.

**SIDELITE:** A stationary glass panel mulled to or installed next to a door.

**SILL:** The horizontal member forming the bottom of a window or exterior door frame; the lowest member of the frame of a structure, resting on the foundation and supporting the frame.

## Glossary of Terms

**SILL HORN:** The extension of the “lip” of a window sill to the outside edge of the casing.

**SINGLE HUNG (SH):** A window unit with two sash with a bottom sash that operates by sliding vertically and is retained in position with the use of balancing devices. The top sash is stationary.

**SLIDING FRENCH DOOR (SFD):** A sliding door utilizing French door style panels.

**SLOT AND TENON:** The method of machining profiles into the ends of stiles and rails in order to produce strong sash frame corners.

**SLOPE:** The measure of the tilt of a line; rise over run.

**SNUBBER:** An interlocking metal bracket attached at the center of the hinge side of a Casement sash and frame with certain heights and both sides of an awning sash and frame with certain heights. It allows operation but pulls the sash tightly against the frame weather strip to maximize performance when closed.

**SOLAR HEAT GAIN COEFFICIENT (SHGC):** The ratio of the solar heat gain entering the space through the fenestration product to the incident solar radiation. Solar heat gain includes directly transmitted solar heat and absorbed solar radiation which is then re-radiated, conducted, or convected into space. The lower a window's SHGC, the less solar heat it transmits to the interior, and the greater its shading ability.

**SPACER:** A perimeter member of an IG used to separate and seal two more pieces of glass.

**SQUARE FOOT (Sq. Ft.):** For measuring the area of a unit. RO width (inches) x RO height (inches) divided by 144 equals the area in square feet of a unit.

**STARBURST:** A semi-elliptical area, the lower center is the point where the dividing spokes meet and radiate outward. May be constructed of glazed sash, ADLs, GBGs or SDLs.

**STATIONARY (O):** A non-operating sash, panel or unit.

**STATIONARY SASH BRACKET:** A bracket used to secure stationary Ultimate Casement and Ultimate Awning sash to the frame. The sash can be removed for replacement by removing the wood stops and bracket screws.

**STILES:** The upright or vertical perimeter pieces of a sash, panel or screen.

**STOOL:** A horizontal trim member that laps the window sill above the apron and extends beyond the interior casing. See apron entry.

**STORM SASH:** A wood framed assembly containing non-removable glass. The storm sash is removed during the summer and replaced with a wood framed screen.

**STRUCTURAL MASONRY BRACKETS:** An installation bracket used with multiple high/wide window units or large doors for added structural support. The brackets are also used to attach the unit in the rough opening in lieu of jamb screws or nailing through the casing.

**STRUCTURAL ROUGH OPENING EXTENSION (SROE):** an-add-on (bump-out) to the structural framing at the rough opening to support the window and allow window alignment with exterior plane of FPIS. The add-on shall be suitable for structural attachment of window.

**SUNBURST:** A semi-elliptical area, the lower center of which contains a sun-like figure with sun rays radiating there from. May be constructed of glazed sash with inverted radii, ADLs or SDLs.1

**SURROUND:** An attractive, protective trim which is secured to an energy panel by an adhesive or vinyl barb to give the glass panel a safe finished edge. Also the aluminum framework for most standard screens.

**TEMPERED GLASS:** Float glass panels heated and then cooled rapidly in a controlled environment. This process makes the glass several times stronger than regular glass. It also makes it safer because when broken it yields small pebble-like fragments.

**TEMPLATE:** A pattern of a window unit or opening from which dimensions and measurements can be determined. Round Tops require templates for replacement units.

**THREE WIDE (3W):** Current term referring to any product or unit when three frames (i.e. separate jambs) are mulled together as a multiple unit.

**TRANSOM:** A window above a window or door. Transoms can be either stationary or operating.

**Triple Pane (TG):** An IG with three panes of glass. (often called Tripane)

**TURN BUTTON:** A vinyl or aluminum button and screw. Buttons are used to secure wood combinations, storm sash and wood screens to the exterior casing or energy panels to the sash or door panel.

**TURN RESTRICTOR:** A device used on a Magnum Tilt-Turn to provide friction to the sash when in the swing position.

**TWO WIDE (2W):** Current term referring to any product or unit when two frames (i.e. separate jambs) are mulled together as a multiple unit.

**Glossary of Terms**

**ULTREX:** A pultruded composite material made of polyester resin and glass fibers with an acrylic cap on primary surfaces.

**U-FACTOR:** (Btu/hr.-sq. ft. - \*F.) A measurement of the amount of heat flow through a product. The lower the U-factor, the greater the resistance to heat flow and better its insulating value.

**UV BLOCKAGE:** Low E glass options will screen out ultraviolet waves while allowing visible light into a structure, reducing fading damage to interior surfaces.

**UNIT:** One single product such as a one-wide casement.

**VENT OPENING:** The total opening created when a door or window is completely open.

**VINYL GLAZING BEAD:** A vinyl extrusion used on clad units which serves the same purpose as a wood glazing bead for wood units.

**VISIBLE LIGHT TRANSMITTANCE (VT):** Percentage of visible light transmitted through the unit.

**WARM EDGE SPACER:** A spacer designed to minimize heat transference between layers of insulating glass.

**WATER RESISTIVE BARRIER:** A material behind an exterior wall covering that is intended to resist liquid water that has penetrated behind the exterior covering from further intruding into the exterior wall assembly.

**WEATHER STRIP:** A strip of resilient material designed to seal the sash and frame members in order to reduce air and water infiltration.

**WINDOW OPENING CONTROL DEVICE (WOCD):** A device that controls a window sash opening to be opened with normal operation of the sash such as to prohibit the free passage of a four inch (102mm) diameter rigid sphere at the lowest opening portion of the window opening, with a release mechanism that allows the sash to be opened to a larger opening area as required for emergency escape and rescue, and that automatically resets when the window sash is fully closed.

**WIRE GLASS:** Glass with wire embedded into the glass when the glass is still in a molten state. This prevents the shattered glass from falling out of the sash if it should break.

**XO:** See OX entry.

## Unit Features on Windows and Doors

Marvin offers an assortment of products and features to fit your window and door requirements. Each product offers similarities that allow multiple products to be positioned in your project and look similar yet distinctive. Below is a collection of the similar characteristics you will find throughout our product lines. For product specific features, refer to the collection or individual chapters for additional information.

### Aluminum Frame and Sash:

- Exterior: Extruded aluminum .050"(1.3) thick
- Standard colors: Stone White, Bahama Brown, Bronze, Pebble Gray, Evergreen, Ebony, Wineberry, Sierra White, Coconut Cream, Cashmere, Cadet Gray, Hampton Sage, Cascade Blue, Bright Silver (pearlescent), Copper (pearlescent), Clay, Gunmetal, Liberty Bronze (pearlescent), or Suede
  - Custom colors are available, please contact your Marvin representative
- Interior: Standard is treated pine bare wood
- Optional species: mixed grain Douglas fir, mahogany, vertical grain Douglas fir, cherry and white oak
  - Cherry and white oak are available on parts towards the interior on clad units only
- The Wood is dried to a moisture content of 12% or less

### Wood Frame and Sash:

- The wood is dried to a moisture content of 12% or less
- Exterior and Interior: Standard is treated pine bare wood
- Optional species: mahogany, and vertical grain Douglas fir
- Cedar Dress Option
  - Brick Mold and Flat Casing
  - Subsill
  - Mull Covers
- See [Ultimate Wood Double Hung Collection Chapter](#) for additional Cedar Dress options

### Interior Finish Options:

- Prime: Factory applied enamel primer
  - Available on Pine products only
- Painted Interior Finish (PIF): Factory applied water-borne acrylic enamel paint applied over compatible primer
  - Available on pine products only.
  - Available colors: White or Designer Black
- Clear Interior Finish (CIF): Factory applied water-borne acrylic enamel clear coat. Applied in two separate coats with light sanding between coats.
  - Available on pine, mahogany, mixed grain Douglas fir, vertical grain Douglas fir, cherry, and white oak
- Stain Interior Finish (SIF): Factory applied water-borne stain. Stain applied over a wood (stain) conditioner. A water-borne acrylic enamel clear coat applied on two separate coats, with light sanding between coats, applied over the stain
  - Available on pine, mahogany, mixed grain Douglas fir, vertical grain Douglas fir, cherry, white oak
  - Colors available: Wheat, Honey, Hazelnut, Leather, Cabernet, and Espresso

### Interior Jamb Extension:

- Jamb extensions are available for various wall thickness factory applied up to 14" (356) wide
  - Finish to match interior
- Jamb extensions over 7 9/16" (192) will be edge glued, 4 11/16" (119) jamb extension will be shipped loose
  - Custom jambs deeper than 6 13/16" for wood and clad will ship separately.

### Insect Screen:

- Standard Screen is roll formed aluminum with Charcoal Fiberglass screen mesh
  - Optional screen mesh is Charcoal High Transparency Fiberglass Mesh, Charcoal Aluminum Wire, Black Aluminum Wire, Bright Aluminum Wire, or Bright Bronze Aluminum Wire
- Interior screen colors: Satin Taupe, Bronze, White or Ebony
- Exterior screen will match the clad frame color
  - See Clad and Wood Swinging Door Collection chapters for sliding and swinging screen options.
- Optional wood interior screen for Casement products.
- Optional wood screen for wood exterior Double Hung windows.

---

**Standard Features on Windows and Doors:****Simulated Divided Lites (SDL):**

- Bar (interior and exterior): 5/8" (16), 7/8" (22), 1 1/8" (29), 1 15/16" (49), 2 13/32" (61) wide bars
- Exterior:
  - Clad units match the exterior clad color
  - Wood Units match the wood species
- Interior:
  - Pine wood standard
  - Finish to match interior
- Insulated glass units available with or without aluminum spacer in airspace
- Pattern: Rectangular, diamond, custom lite layouts available, contact your Marvin representative

*NOTE: Due to the inherent qualities of tempered glass, daylight gaps may be seen when using simulated divided lite bars. Daylight gaps could be visible between the internal spacer bar and surface applied bars when viewing from an acute angle to the glass on the following applications:*

- Tempered glass over 72" high while using 5/8" SDL bars
- Tempered glass over 91" high while using 7/8" SDL bars.

**Grilles-Between-the-Glass (GBG):**

- 23/32" (18) white contoured aluminum bar
- Exterior Colors: Stone White, Sierra White, Coconut Cream, Evergreen, Pebble Gray, Ebony, Bronze, Bahama Brown, Wineberry, and Cashmere
  - The exterior GBG color is designed to best match the Marvin clad colors when used with Low E glass
  - The use of different types of glazing options may alter the exterior GBG color appearance
- Interior Colors: White, Bronze, Pebble Gray, Sierra, and Ebony (only available with Ebony exterior)
- Optional flat aluminum bar (5/8") available
  - Exterior and Interior Colors: White, Sand Stone, Dark Brown, Dark Bronze, Green, Bright Gold, Champagne, and Light Bronze

**Authentic Divided Lite (ADL):**

- Wood units only
- Bar (interior and exterior): single glazed 7/8" (22) wide bars, insulated glass 1 11/16" (43) wide bars.
- Available in standard pine and optional mahogany, or vertical grain Douglas fir
- Finish to match interior and exterior and species of door
- Pattern: Rectangular, custom lite layouts available, contact your Marvin representative
- ADL glazing options not available with Argon. Sealed air units are standard.

**Accessories:**

- Installation brackets: 6 3/8" (162), 9 3/8" (238), or 15 3/8" (390)
- Masonry brackets: 6" (152), or 10" (254)
- Exterior wood casings: Brick Mould Casing (BMC), Flat Casing, Special Casing 3 (SPC3), Special Casing 7 (SPC7), Special Casing 21 (SPC21), Special Casing 18 (SPC18), Special Casing 26 (SPC26)
- Aluminum extrusions: Brick Mould Casing (BMC), Flat Casing, Columbus Casing, Grayson Casing, Stratton Casing, Thorton Casing, Potter Casing
- Aluminum Extrusions: Mullion Cover, Frame Expander, Mullion Expander, Subsills and Subsill End Caps
- Jamb Jack Installation kit
- IZ3 Installation kit



## **IZ3/IZ4: Code Requirements and Glazing**

### **Regional Product Design Pressure Requirements**

#### **International Residential Code/International Building Code:**

This set of building codes has fast been replacing the regional codes we have had available in the past. These codes represent the results of the many code governing agencies getting together to come up with a singular code language that meets all geographical locations within the building industry.

The International Residential Code is written for typical residential construction and the International Building Code is more for Commercial use. Within these codes is language that places a building site geographically into different zones based on wind-speed and proximity to the ocean as listed here:

#### **Impact Glazing Zone 1 (IZ1):**

130mph and up to but not including 140 mph and within 1-mile of the mean high tide line and Hawaii. Design pressures in this zone will exceed 40psf for negative loads. The I-codes also specifically require wind-borne debris construction in this zone. Windows and doors must be designed to withstand an impact of a 4' long 2x4 stud shot out of a cannon at 40' per second (27mph) to simulate flying debris followed by a total of 9,000 high wind cycles to simulate a hurricane.

#### **Impact Glazing Zone 2 (IZ2):**

140mph and up to but not including 150mph and more than 1-mile from the mean high tide line. Pressures in this zone approach 50psf for negative loads. Wind-borne debris requirements are identical to Zone 1.

#### **Impact Glazing Zone 3 (IZ3):**

For winds 150mph and up to 160mph, or 140mph and up to 160mph and within 1-mile of the mean high tide line. Design pressures in this zone can approach 65psf for negative loads. The I-codes specifically require wind-borne debris construction in this zone. Windows and Doors must be designed to withstand an impact of an 8' long 2x4 stud shot from a cannon at 50' per second (34mph) to simulate flying debris followed by a 9,000 high wind cycles that simulate a hurricane.

#### **The make-up of IZ3 glass:**

- Exterior piece of glass is annealed or tempered.
- Interior piece of glass is laminated glass which is composed of a layer of PVB or SGP sandwiched between two pieces of annealed glass.

#### **Impact Glazing Zone 4 (IZ4):**

This is considered a high velocity wind zone and encompasses all areas with wind speeds in excess of 160mph. Design pressures in this zone often exceed 65psf and can approach 100psf. Wind-borne debris requirements include everything from Zone 3 as well as as possible multiple hits per test unit and mullions.

*NOTE: Refer to wind speed map and ASTM E1996, subsection 6.2.2 for more information.*

**Egress Code: International Building Code - 2021, 2024**

**International Building Code - 2021 and 2024**

Chapter 10, Section 1031 in the 2021 and 2024 Code - Emergency Escape and Rescue

**Minimum Size:** Emergency escape and rescue openings shall have a minimum net clear opening of 5.7 square feet (.053 m<sup>2</sup>). Exception: The minimum net clear opening for grade-floor emergency escape and rescue openings shall be 5.0 square feet (0.46m<sup>2</sup>).

**Minimum Dimensions:** The minimum net clear opening height dimension shall be 24 inches (610). The minimum net clear opening width dimension shall be 20 inches (508). The net clear opening dimensions shall be the result of normal operation of the opening.

**Maximum Height from Floor:** Emergency escape and rescue openings shall have the bottom of the clear opening not greater than 44 inches (1118) measured from the floor.

**Operational Constraints:** Emergency escape and rescue openings shall be operational from the inside of the room without the use of keys or tools. The 2018 code added the following sentence - window-opening control devices complying with ASTM F2090 shall be permitted for use on windows serving as a required emergency escape and rescue opening.

Code restrictions may vary depending on your local building code.

*NOTE: Net Clear Opening drawing is located in individual chapter with measurement conversions. UCA sample below.*

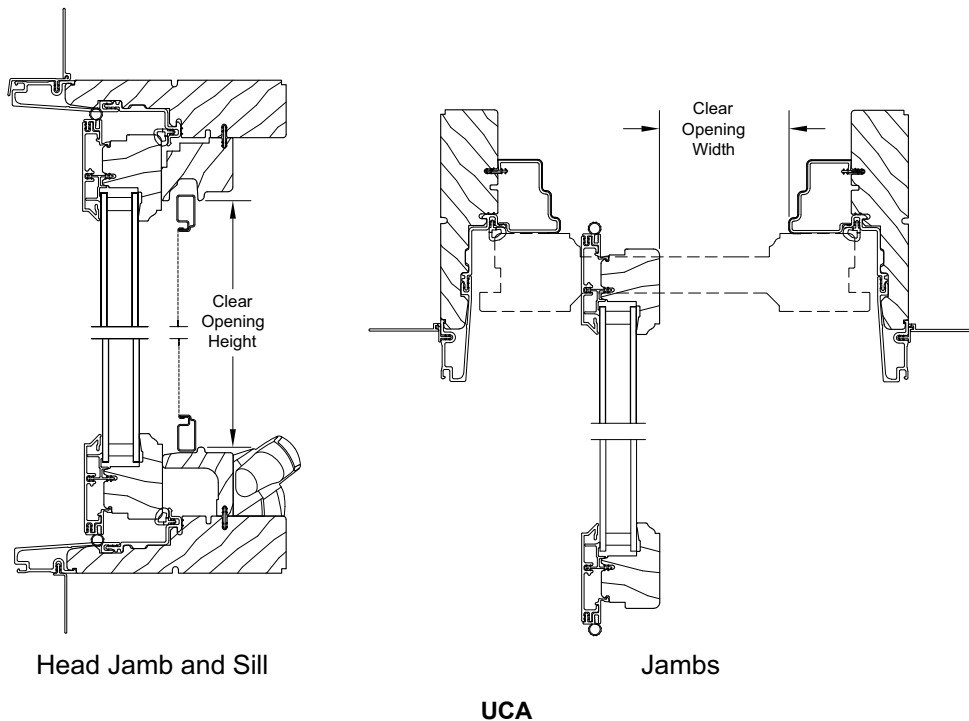

## **Chain of Custody Certification**

Marvin® offers customers the option to order chain-of-custody (COC) certified products through the Forest Stewardship Council® (FSC® License Code - FSC-C041268) Percentage System. The output claim for eligible products will be FSC® Mix XX%. The COC process is your assurance that the wood is legally and ethically harvested since it is tracked from the forest, through the manufacturing processes, and eventually to the end consumer.

When specifying the FSC® Percentage System, Marvin will utilize only FSC® certified COC and controlled material. Douglas Fir is the one species available from Marvin that is certified through the COC system. Invoices for the FSC® Mix Certified products will include the claim statement “FSC® Mix XX%” along with the Marvin FSC® certificate number.

FSC® is an established, independent organization recognized as a leader in promotion of responsible forest management practices. Marvin has a genuine appreciation for the critical role forests play in the quality of life within the global ecosystems. Properly managed forests supply a continual source of wood. Marvin continues to support sustainable forestry management and is committed to conserving natural resources, including efforts to preserve old growth and ancient rain forests. For more information on FSC®, go to [www.fscus.org](http://www.fscus.org).

## AAMA Paint & Coating Specifications

The American Architectural Manufacturer's Association (AAMA) is a trade association representing firms engaged in the manufacture and sale of architectural building components and related products. Voluntary standard have been created to test a product's durability, strength, resistance to environmental degradation and longevity. AAMA has a standard set of stringent performance tests designed to evaluate high-performance coatings on fenestration products. the quality of these finishes is affected by the pigment formula as well as the resin used to bind pigment to the substrate surface. Marvin Windows and Door uses an exceedingly strong fluropolymer resin material with hi-quality complex ceramic pigment mix to create a finish that meets AAMA 2605 voluntary performance requirements and test procedures for pigmented organic coatings on extruded aluminum and panels. In addition, a five-step pre-treatment process ensures thorough, firm bonding between the resin and the extruded aluminum substrate. The chart below illustrated the difference between the AAMA ratings, from aesthetic changes such as chalking and color retention to testing designed to replicate harsh coastal conditions.

AAMA Paint Specifications for Clad Units		
<b>South Florida Weathering:</b>		
Specification Details	AAMA 2603	AAMA 2605
Color Retention	1 yr "Slight" fade	10 yrs Fade = 5 Delta E
Chalk Resistance	1 yr "Slight" chalk	10 yrs chalk = 8
Glass Retention	no specification	10 yrs 50% retention
Erosion Resistance	no specification	10 yrs 10% loss
Dry Film Thickness	0.8 mils minimum	1.2 mils minimum
Pretreatment System	Chrome/chrome free	Chrome = 40 mg/sq ft
<b>Chemical Resistance</b>		
Specification Details	AAMA 2603	AAMA 2605
Muriatic Acid	15 minutes/no attack	15 minutes/no attack
Mortar	24 hours/no attack	24 hours/no attack
Nitric Acid	max 5D E units change	max 5D E units change
Detergent	72 hours/no attack	72 hours/no attack
Window Cleaner	no specification	24 hours/no attack
<b>Accelerated Testing</b>		
Specification Details	AAMA 2603	AAMA 2605
Salt Spray	1,500 hours	4,000 hours
Humidity	1,500 hours	4,000 hours

**WDMA Hallmark Certification Program**

[www.wdma.com](http://www.wdma.com)

Marvin Windows and Doors is a member of the Window and Door Manufacturers Association (WDMA) and uses their Hallmark Certification program to certify products. Please refer to product chapters for specific Hallmark Certification information.

Any manufacturer who complies with standards set by the Window and Door Manufacturer's Association's standards is eligible to participate in the Hallmark Certification program. In order to participate, products must be tested and pass one of the performance rating levels as defined in the applicable standard. In order for WDMA to ensure those manufacturers' products remain in continuing compliance; unannounced periodic in-plant inspections are conducted. Following this process authorizes the manufacturer to label the products as certified and gives the consumer and specifiers assurance that purchased products comply with industry standards.

Standard Requirements	
Aluminum and Wood Windows and Doors	AAMA/WDMA/CSA 101/I.S.2/A440, NAFS-11, NAFS-17
Water - Repellent Preservative	WDMA I.S.4
Non-Pressure Treatment for Millwork	

**Industry and Federal Performance Standards**

**Marvin products have been tested and passed the following applicable test procedures referenced by WDMA, AAMA, IGCC, IGMA, SMA and CMBSO.**

AAMA 2603	Voluntary Specification, Performance Requirements and Test Procedures for Pigmented Organic Coatings on Aluminum Extrusions and Panels
AAMA 2605	Voluntary Specification, Performance Requirements and Test Procedures for Superior Performing Organic Coatings on Aluminum Extrusions and Panels
WDMA I.S.2	Industry Standard for Water-Repellent Preservative Treatment of Millwork
WDMA TM-14-09	Test Methods for Factory Applied and Pigmented Interior Pre-finished Wood and Wood Cellulose Composites Used for Millwork
ANSI A 201-2	Specification for Aluminum Sliding Screen Doors; SMA 2005
ASTM C1036	Standard Specification for Flat Glass
ASTM D3310	Standard Specification for Adhesives Used in Non-Structural Glued Lumber Products
ASTM E90	Laboratory Measurement of Airborne Sound Transmission of Building Partitions
ASTM E283	Standard Test Method for Rate of Air Leakage Through Exterior Windows, Curtain Walls and Doors
ASTM E330	Standard Test Method for Structural Performance of Exterior Windows, Curtain Walls and Doors by Uniform Static Air Pressure Differences
ASTM E331	Standard Test Method for Water Penetration of Exterior Windows, Curtain Walls and Doors by Uniform Static Air Pressure Differences
ASTM E413	Determination of Sound Transmission Class
ASTM E547	Standard Test Method for Water Penetration of Exterior Windows, Curtain Walls and Doors by Cyclic Static Air Pressure Differences
ASTM E1300	Standard Practice for Determining the Load Resistance of Glass in Buildings
ASTM E1886	Standard Test Method for Performance of Exterior Windows, Curtains Walls, Doors, and Impact Protective Systems. Impacted by Missile(s) and Exposed to Cyclic Pressure Differentials
ASTM E1996	Standard Specification for Performance of Exterior Windows, Curtain Walls, Doors, and Impact. Protective Systems Impacted by Windborne Debris in Hurricanes
ASTM E2068	Standard Test Method for Determination of Operating Force of Sliding Windows and Doors
ASTM E2190	Standard Specification for Insulating Glass Unit Performance and Evaluation
ASTM E1425	Standard Practice for Determining the Acoustical Performance of Windows, Doors, Skylight, and Glazed Wall Systems
ASTM F588	Standard Test Method for Resistance of Window Assemblies to Forced Entry
ASTM F842	Standard Entry Method for Measurements of Forced Entry Resistance of Horizontal Sliding Door Assemblies
ASTM F2090	Standard Specification for Window Fall Prevention Devices with Emergency Escape (Egress) Release Mechanisms
SMA 1004	Specification for Aluminum Tubular Frame Screen for Windows
AAMA/WDMA/CSA 101/I.S. 2/A440-17	NAFS - North American Fenestration Standard/Specification for windows, doors, and skylights
ANSI/NFRC 100-2017	Procedure for Determining Fenestration Product Thermal Attributes

**Product Rating Codes / Performance Classes**

<u>Product Type</u>		<u>Performance Class and Grade</u>
AP = Awning, Hopper, Projected Window	MA = Mullion Assembly	R = Residential
AP = Awning, Hopper, Projected Window	POW = Parallel Opening Window	LC = Light Commercial
C = Casement Windows	SD = Sliding Door	CW=Commercial
DAW = Dual Action Windows	SGD = Sliding Glass Doors	AW =Architectural
DASHD = Dual Action Side-Hinges Door	SHD = Side-Hinged Door	
FD = Fixed Door	SHW = Side-Hinges (inswinging) window	
FW = Fixed Windows	SLT = Side Lite	
H = Hung Windows	SP = Specialty Product	
HGD = Hinged Glass Doors	SSP = Secondary Storm Product	
HP = Horizontally Pivoted Window	TH = Top-Hinged Window	
HS = Horizontal Sliding Windows	VP = Vertical Pivoted Window	
LW DASHD = Limited Water Dual Action Side Hinged Door	VS = Vertical Sliding Window	

**Product Rating Code for '11**

**Example**

**LC - PG25 - H**

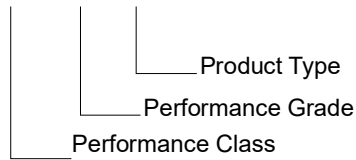

Product Rating Codes / Performance Classes/Design Pressure Ratings

Performance Classes ('08, '11, '17 Standards)	(psf) Min. DP	(psf) Struct. Press.	(psf) Water Press.	(cfm/ft <sup>2</sup> ) Max. Air. Inf.
R = Residential	15	22.56	2.92	0.3 (1.57 psf)
LC = Light Commercial	25	37.59	3.76	0.3 (1.57 psf)
CW = Commercial	30	45.11	4.59	0.3 (1.57 psf)
AW = Architectural	40	60.15	7.95	0.1 or 0.3 (6.27 psf)
Metric	(Pa)	(Pa)	(Pa)	(L/s/m <sup>2</sup> )
R = Residential	720	1080	140	1.5 (75 Pa)
LC = Light Commercial	1200	1800	180	1.5 (75 Pa)
CW = Commercial	1440	2160	220	1.5 (75 Pa)
AW = Architectural	1920	2880	380	0.5 or 1.5 (300 Pa)

NOTE: AAMA/WDMA chose to establish 2.86 psf as the minimum air pressure used during water testing although it is greater than 15% of the design pressure at DP15.

Performance Grade						
Performance Grade		PG15	PG20	PG25	PG30	PG35
Design Pressure (DP)	(psf)	15.04	20.05	25.06	30.08	35.09
Structural Test Pressure (STP)	(psf)	22.56	30.08	37.59	45.11	52.63
Water penetration resistance test pressure	(psf)	2.92	3.13	3.76	4.59	5.43
Performance Grade		PG40	PG45	PG50	PG55	PG60
Design Pressure (DP)	(psf)	40.10	45.11	50.13	55.14	60.15
Structural Test Pressure (STP)	(psf)	60.15	67.67	75.19	82.71	90.23
Water penetration resistance test pressure	(psf)	6.06	6.89	7.52	8.35	9.19
Metric Performance Grade		PG15	PG20	PG25	PG30	PG35
Design Pressure (DP)	(Pa)	720	960	1,200	1,440	1,680
Structural Test Pressure (STP)	(Pa)	1,080	1,440	1,800	2,160	2,520
Water penetration resistance test pressure	(Pa)	140	150	180	220	260
Metric Performance Grade		PG40	PG45	PG50	PG55	PG60
Design Pressure (DP)	(Pa)	1,920	2,160	2,400	2,640	2,880
Structural Test Pressure (STP)	(Pa)	2,880	3,240	3,600	3,960	4,320
Water penetration resistance test pressure	(Pa)	290	330	360	400	440



STC and OITC Class Values

Marvin Sound Transmission Class and Outdoor - Indoor Transmission Class Values							
Product Type	Exterior Glazing	Airspace	Interior Glazing	STC	OITC	Additional Information	STC Report #
<b>Ultimate Double Hung G2</b>							
UDH G2 (47 3/16 x 59 1/8)	1/8" (3.1) Annealed	5/8" (16.0)	1/8" (3.1) Annealed	27	23		<a href="#">ESP018375P-2</a>
UDH G2 (47 3/16 x 59 1/8)	1/8" (3.1) Annealed	1/4" (6.5)	1/8" (3.1) Annealed	28	24	Tri-pane: two 1/4" air spaces with 1/8" center pane	<a href="#">ESP016170P-2</a>
UDH G2 (47 3/16 x 59 1/8)	1/8" (3.1) Annealed	19/32" (14.5)	3/16" (4.7) Annealed	30	26		<a href="#">ESP020753P-2</a>
UDH G2 (47 3/16 x 59 1/8)	1/4" (5.7) Annealed	3/8" (9.8)	1/4" (6.0) Lami	30	27		<a href="#">ESP016170P-4</a>
UDH G2 (47 3/16 x 59 1/8)	1/4" (6.0) Lami	3/8" (9.8)	1/4" (6.0) Lami	31	27		<a href="#">ESP016170P-5</a>
UDH G2 (47 3/16 x 59 1/8)	1/8" (3.1) Annealed	7/16" (11.5)	5/16" (7.8) Lami	31	26	Not NFRC-certified	<a href="#">ESP020753P-1</a>
UDH G2 (47 3/16 x 59 1/8)	9/32" (7.0) Lami	5/16" (8.0)	9/32" (7.0) Lami	31	27	Not NFRC-certified	<a href="#">ESP016170P-7</a>
UDH G2 (47 3/16 x 59 1/8)	1/8" (3.1) Annealed	7/16" (11.5)	11/32" ( 8.6 ) Lami	31	27	I23	<a href="#">ESP018375P-5</a>
UDH G2 (47 3/16 x 59 1/8)	3/16" (4.7) Annealed	7/16" (11.5)	1/4" (6.0) Lami	31	28		<a href="#">ESP018375P-3</a>
UDH G2(47 3/16 x 59 1/8)	1/4" (5.9) Annealed	5/16" (8.0)	5/16" (7.8) Lami	31	29	Not NFRC-certified	<a href="#">ESP016170P-6</a>
UDH G2 (47 3/16 x 59 1/8)	3/16" (4.7) Annealed	5/16" (8.0)	11/32" ( 8.6 ) Lami	32	29	I23	<a href="#">ESP018375P-7</a>
UDH G2 (47 3/16 x 59 1/8)	1/8" (3.1) Annealed	5/8" (16.0)	1/8" (3.1) Annealed	35	28	1/8" Clad Storm Combination	<a href="#">ESP016170P-14</a>
UDH G2 (47 3/16 x 59 1/8)	1/8" (3.1) Annealed	1/4" (6.5)	1/8" (3.1) Annealed	36	30	Tri-pane: two 1/4" air spaces w/ 1/8" center pane, 1/8" Clad Storm Comb	<a href="#">ESP016170P-15</a>
UDH G2 (47 3/16 x 59 1/8)	1/4" (5.7) Annealed	3/8" (9.8)	1/4" (6.0) Lami	39	32	1/8" Clad Storm Combination	<a href="#">ESP016170P-19</a>
UDH G2(47 3/16 x 59 1/8)	1/4" (6.0) Lami	3/8" (9.8)	1/4" (6.0) Lami	40	33	1/8" Clad Storm Combination	<a href="#">ESP016170P-17</a>
UDH G2 (47 3/16 x 59 1/8)	3/16" (4.7) Annealed	7/16" (11.5)	1/4" (6.0) Lami	40	33	1/8" Clad Storm Combination	<a href="#">ESP016170P-18</a>
UDH G2 (47 3/16 x 59 1/8)	9/32" (7.0) Lami	5/16" (8.0)	9/32" (7.0) Lami	40	33	1/8" Clad Storm Combination -No NFRC-cert	<a href="#">ESP016170P-12</a>
UDH G2 (47 3/16 x 59 1/8)	1/4" (5.9) Annealed	5/16" (8.0)	5/16" (7.8) Lami	41	35	1/8" Clad Storm Combination -No NFRC-cert	<a href="#">ESP016170P-16</a>
UDH P G2 (47 3/16 x 59 1/8)	1/8" (3.1) Annealed	5/8" (16.0)	1/8" (3.1) Annealed	29	23		<a href="#">ESP016170P-21</a>
UDH P G2 (47 3/16 x 59 1/8)	1/8" (3.1) Annealed	1/4" (6.5)	1/8" (3.1) Annealed	30	25	Tri-pane: two 1/4" air spaces with 1/8" center pane	<a href="#">ESP016170P-24</a>
UDH P G2 (47 3/16 x 59 1/8)	1/4" (6.0) Lami	3/8" (9.8)	1/4" (5.7) Annealed	34	29		<a href="#">ESP016170P-26</a>
UDH P G2 (47 3/16 x 59 1/8)	1/4" (6.0) Lami	3/8" (9.8)	1/4" (6.0) Lami	35	30		<a href="#">ESP016170P-25</a>
UDH P G2 (47 3/16 x 59 1/8)	3/16" (4.7) Annealed	7/16" (11.5)	1/4" (6.0) Lami	35	29		<a href="#">ESP016170P-23</a>
UDH P G2 (47 3/16 x 59 1/8)	1/4" (5.9) Annealed	5/16" (8.0)	5/16" (7.8) Lami	35	31	Not NFRC-certified	<a href="#">ESP016170P-22</a>
UDH P G2 (47 3/16 x 59 1/8)	9/32" (7.0) Lami	5/16" (8.0)	9/32" (7.0) Lami	35	30	Not NFRC-certified	<a href="#">ESP016170P-27</a>
UDH P G2 (47 3/16 x 59 1/8)	1/8" (3.1) Annealed	1/4" (6.5)	9/16" (13.6) Lami	35	31		<a href="#">ESP016170P-29</a>
<b>Ultimate Wood Double Hung</b>							
UWDH 3026	1/8" (3.1) Annealed	7/16" (11.5)	1/8" (3.1) Annealed	35	26	3/32" (2) Wood Storm Comb	<a href="#">66263-4</a>
UWDH 3026	3/16" (4.7) Annealed	3/8" (9.8)	1/8" (3.1) Annealed	36	27	3/32" (2) Wood Storm Comb	<a href="#">66263-5</a>
UWDH 3026	5/32" (3.9) Annealed	3/8" (9.8)	1/4" (6) Lami	37	28	3/32" (2) Wood Storm Comb	<a href="#">66263-6</a>
UWDHP 6878	1/4" (5.7) Annealed	9/16" (14.5)	1/4" (6) Lami	34	27	2" (51) Sash	<a href="#">66263-7</a>
<b>Ultimate Wood Double Hung Magnum (see NOTE below)</b>							
UWDHM FS 48"(1219) X 60"(1524) (7/8)	1/4" (6) LAMI	3/8" (9.8)	1/4" (6) LAMI	33	28		<a href="#">ESP-015798P-3</a>
UWDHM FS 48"(1219) X 60"(1524) (7/8)	1/4" (6) LAMI	5/16" (8)	5/16" (8.6) LAMI	34	29		<a href="#">ESP-015798P-2</a>
UWDHM FS 48"(1219) X 60"(1524) (7/8)	1/8" (3.1) Annealed	1/4" (6.5)	1/8" (3.1) Annealed	28	24	Tri-pane: two 1/4" air spaces with 1/8" center pane	<a href="#">ESP-015798P-1</a>
UWDHM FS 47 7/8 X 88 (11/16)	1/8" (3.1) Annealed	7/16" (11.5)	1/8" (3.1) Annealed	27	22		76430
UWDHM FS 47 7/8 X 88 (11/16)	3/16" (4.7) Annealed	3/8" (9.8)	1/8" (3.1) Annealed	30	25		
UWDHM FS 47 7/8 X 88 (11/16)	1/4" (5.7) Annealed	5/16" (8)	5/32" (3.9) Annealed	31	26		
UWDHM FS 47 7/8 X 88 (11/16)	1/4" (6) LAMI	9/32" (7)	3/16" (4.7) Annealed	31	26		
<b>Ultimate Wood Double Hung Magnum</b>							
UWDHM FS 48" (1219) X 60"(1524)	(with 7/8" IG) 1/4" (6) LAMI	3/8" (9.8)	1/4" (6) LAMI	33	27		<a href="#">ESP-015798P-6</a>
UWDHM FS 48" (1219) X 60"(1524)	1/4" (6) LAMI	5/16" (8)	5/16" (8.6) LAMI	34	29		<a href="#">ESP-015798P-5</a>
UWDHM FS 48" (1219) X 60"(1524)	1/8" (3.1) Annealed	1/4" (6.5)	1/8" (3.1) Annealed	28	24	Tri-pane: two 1/4" air spaces with 1/8" center pane	<a href="#">ESP-015798P-4</a>

NOTE: The test reports in the UWDHM section are for Ultimate Double Hung Magnum (UDHM) product, a product that is no longer available. However, in testing the UDHM product, it qualifies the UWDHM product as well.

STC and OITC Class Values

Marvin Sound Transmission Class and Outdoor - Indoor Transmission Class Values							
Product Type	Exterior Glazing	Airspace	Interior Glazing	STC	OITC	Additional Information	STC Report #
Ultimate Casement							
Values for wood and clad product UCA, UCART, UPCA, UCAP, UCARTP, UPCAP							
UCA 2460 3/4" (19)	1/8" (3.1) Annealed	1/2" (13)	1/8" (3.1) Annealed	29	23		<a href="#">TCT005872P-1</a>
UCA 2460 3/4" (19)	1/4" (5.7) Annealed	5/16" (8)	1/4" (6) LAMI	34	29		<a href="#">ESP016574P-2</a>
UCA 2460 3/4" (19)	1/4" (6) LAMI	9/32" (7)	1/4" (6) LAMI	35	30		<a href="#">ESP016574P-3</a>
UCA 2460 3/4" (19)	1/8" (3.1) Annealed	5/16" (8)	11/32" (8.6) PVB	35	31	IZ3	<a href="#">ESP017287P-4</a>
UCA 2460 3/4" (19)	3/16" (4.7) Annealed	5/16" (8)	1/4" (6) LAMI	35	30		<a href="#">ESP016574P-4</a>
UCA 2460 3/4" (19)	3/16" (4.7) Annealed	1/4" (6.5)	11/32" (8.6) PVB	37	31	IZ3	<a href="#">ESP017287P-1</a>
UCA 2460 3/4" (19)	1/8" (3.1) Annealed	1/2" (13)	1/8" (3.1) Annealed	46	34	interior sash 1/8" glass, 4 1/4" airspace	<a href="#">TCT005872P-1</a>
UCA 2460 1" (25)	1/8" (3.1) Annealed	5/16" (8)	1/8" (3.1) Annealed	30	25	Tri-pane: two 5/16" air spaces, with 1/8" center	<a href="#">ESP016574P-5</a>
UCA 2460 1" (25)	1/4" (5.7) Annealed	1/2" (13)	1/4" (6) LAMI	34	28		<a href="#">ESP016574P-10</a>
UCA 2460 1" (25)	3/16" (4.7) Annealed	9/16" (14.5)	1/4" (5.7) Annealed	34	27		<a href="#">TCT005872P-1</a>
UCA 2460 1" (25)	1/4" (6) LAMI	1/2" (13)	1/4" (6) LAMI	35	28		<a href="#">ESP016574P-11</a>
UCA 2460 1" (25)	9/32" (7) Lami	7/16" (11.5)	9/32" (7) Lami	35	29	Not NFRC-certified	<a href="#">ESP016574P-13</a>
UCA 2460 1" (25)	1/4" (5.9) Annealed	7/16" (11.5)	5/16" (7.8 ) Lami	37	32	Not NFRC-certified	<a href="#">ESP017287P-3</a>
UCA 2460 1" (25)	3/16" (4.7) Annealed	9/32" (7)	17/32" (13.6 ) Lami	37	34		<a href="#">ESP016574P-9</a>
UCA 2460 1" (25)	3/16" (4.7) Annealed	9/16" (14.5)	1/4" (6) LAMI	37	30		<a href="#">ESP016574P-12</a>
UCA 2460 1" (25)	3/16" (4.7) Annealed	7/16" (11.5)	11/32" (8.6) PVB	37	31	IZ3	<a href="#">ESP017287P-2</a>
UCA 2460 1" (25)	3/16" (4.7) Annealed	3/8" (9.8)	13/32" (10.1) PVB	38	33		<a href="#">ESP017287P-6</a>
UCA 2460 1" (25)	3/16" (4.7) Annealed	9/16" (14.5)	1/4" (5.7) Annealed	47	36	interior sash 1/8" glass, 4 1/4" airspace	<a href="#">TCT005872P-1</a>
UCAP 4860 1" (25)	3/16" (4.7) Annealed	9/16" (14.5)	1/4" (6) LAMI	36	30		<a href="#">ESP016574P-15</a>
UCAP 4860 1" (25)	1/4" (5.7) Annealed	1/2" (13.0)	1/4" (6) LAMI	34	29		<a href="#">ESP016574P-16</a>
UCAP 4860 1" (25)	1/4" (6) LAMI	1/2" (13.0)	1/4" (6) LAMI	35	29		<a href="#">ESP016574P-17</a>
UCAP 4860 1" (25)	3/16" (4.7) Annealed	9/32" (7)	17/32" (13.6 ) Lami	36	33		<a href="#">ESP016574P-18</a>
UCAP 4860 1" (25)	1/8" (3.1) Annealed	5/16" (8)	1/8" (3.1) Annealed	29	24	Tri-pane: two 5/16" air spaces, with 1/8" center	<a href="#">ESP016574P-19</a>
UCAP 4860 1" (25)	9/32" (7) Lami	7/16" (11.5)	9/32" (7) Lami	36	30		<a href="#">ESP016574P-23</a>
UCAP 4860 1" (25)	1/4" (5.9) Annealed	7/16" (11.5)	5/16" (7.8 ) Lami	36	32	Not NFRC-certified	<a href="#">ESP016574P-22</a>
UCAP 4860 1" (25)	3/16" (4.7) Annealed	5/8" (16)	3/16" (4.7) Annealed	31	25		
UCAP 4860 1" (25)	3/16" (4.7) Annealed	9/16" (14)	1/4" (5.7) Annealed	34	28		<a href="#">TCT005872P-2</a>
UGL 5040	1/8" (3.1) Annealed	7/16" (11.5)	1/8" (3.1) Annealed	27	22		
UGL 5040	1/8" (3.1) Annealed	3/8" (10)	3/16" (4.7) Annealed	32	26		<a href="#">TCT006299P-CUGL</a>
UGL 5040	1/8" (3.1) Annealed	7/16" (11.5)	1/8" (3.1) Annealed	33	25	1/8" Combination to the exterior	
UGL 5040	1/8" (3.1) Annealed	3/8" (10)	3/16" (4.7) Annealed	37	27	1/8" Combination to the exterior	
UGL 5040	3/16" (4.7) Annealed	9/32" ( 7.0)	1/4" (6.0) Lami	32	29		<a href="#">ESP020754P-4rev1</a>
UGL 5040	5/32" (3.9)	9/32" ( 7.0)	9/32" ( 7.0) Lami	30	27	Not NFRC-certified.	<a href="#">ESP020754P-5</a>
UGL 5040	3/16" (4.7) Annealed	9/32" ( 7.0)	1/4" (6.0) Lami	37	31	1/8" Combination to the exterior	<a href="#">ESP020754P-2rev1</a>
UGL 5040	5/32" (3.9)	9/32" ( 7.0)	9/32" ( 7.0) Lami	37	30	1/2" Comb to the exterior. No NFRC-cert	<a href="#">ESP020754P-3</a>
UGLP 4050	3/16" (4.7) Annealed	5/16" (8)	3/16" (4.7) Annealed	31	26		<a href="#">TCT006299P-CUGLP</a>
UGLP 4050	1/8" (3.1) Annealed	3/8" (10)	3/16" (4.7) Annealed	31	26		
UGLP 4050	3/16" (4.7) Annealed	9/32" (7)	1/4" (6.0) Lami	34	30		<a href="#">ESP020754P-1</a>
Ultimate Direct Glaze							
UDG Rect FS 47 3/16" x 59 3/32"	5/32" (3.9) Annealed	7/16" (11.5)	5/32" (3.9) Annealed	28	24		<a href="#">ESP014020-2</a>
UDG Rect FS 47 3/16" x 59 3/32"	1/4" (5.7) Annealed	7/16" (11.5)	1/4" (6.0) Lami	33	27		<a href="#">ESP014020-3</a>
UDG Rect FS 47.2 x 59.1	1/8" ( 3.1) Annealed	7/16" (11.5)	1/8" ( 3.1 ) Annealed	27	23		<a href="#">ESP019269P-4</a>
UDG Rect FS 47.2 x 59.1	3/16" ( 4.7 ) Annealed	7/16" (11.5)	3/16" ( 4.7 ) Annealed	29	26		<a href="#">ESP019269P-9</a>
UDG Rect FS 47.2 x 59.1	1/4" ( 5.7 ) Annealed	7/16" (11.5)	1/4" ( 5.7 ) Annealed	30	26		<a href="#">ESP019269P-8</a>
UDG Rect FS 47.2 x 59.1	5/32" ( 3.9 ) Annealed	7/16" (11.5)	3/16" ( 4.7 ) Annealed	32	28		<a href="#">ESP019269P-5</a>
UDG Rect FS 47.2 x 59.1	3/16" ( 4.7 ) Annealed	7/16" (11.5)	1/4" ( 6.0 ) Lami	34	29		<a href="#">ESP019269P-2</a>
UDG Rect FS 47.2 x 59.1	1/4" ( 6.0 ) Lami	7/16" (11.5)	1/4" ( 6.0 ) Lami	33	28		<a href="#">ESP019269P-11</a>
UDG Rect FS 47.2 x 59.1	1/8" ( 3.1) Annealed	5/16" ( 8.0 )	1/8" ( 3.1) Annealed	27	23	tripane- two 5/16" airspaces with 1/8" center	<a href="#">ESP019269P-7</a>
UDG Rect FS 47.2 x 59.1	1/8" ( 3.1) Annealed	5/16" ( 8.0 )	1/4" ( 6.0 ) Lami	33	27	tripane- two 5/16" airspaces with 1/8" center	<a href="#">ESP019269P-6</a>
UDG Rect FS 47.2 x 59.1	3/16" ( 4.7 ) Annealed	3/8" ( 9.8 )	13/32" (10.1) SGP	34	30	IZ3	<a href="#">ESP019269P-3</a>
UDG Rect FS 47.2 x 59.1	9/32" ( 7.0 ) Lami	7/16" (11.5)	9/32" ( 7.0 ) Lami	36	30	Not NFRC-certification	<a href="#">ESP019269P-1</a>
UDG Rect FS 47.2 x 59.1	15/64" ( 5.9 ) Annealed	7/16" (11.5)	5/16" ( 7.8 ) Lami	36	31	Not NFRC certified	<a href="#">ESP019269P-10</a>

**STC and OITC Class Values**

Marvin Sound Transmission Class and Outdoor - Indoor Transmission Class Values							
Product Type	Exterior Glazing	Airspace	Interior Glazing	STC	OITC	Additional Information	STC Report #
<b>Ultimate Sliding Patio Door</b>							
USPD 6068	1/8" (3.1) Tempered	1/2" (13.0)	1/8" (3.1) Tempered	29	24		<a href="#">ESP023470P-12</a>
USPD 6068	1/8" (3.1) Tempered	7/16" (11.5)	3/16" (4.7) Tempered	31	26		<a href="#">ESP023470P-20</a>
USPD 6068	1/8" (3.1) Tempered	3/8" (9.8)	1/4" (5.7) Tempered	31	27		<a href="#">ESP023470P-14</a>
USPD 6068	5/32" (3.9) Tempered	7/16" (11.5)	5/32" (3.9) Tempered	30	25		<a href="#">ESP023470P-18</a>
USPD 6068	1/4" (5.7) Tempered	5/16" (8.0)	1/4" (5.7) Tempered	31	28		<a href="#">ESP023470P-19</a>
USPD 6068	1/8" (3.1) Tempered	3/8" (9.8)	1/4" (6) Lami	31	27		<a href="#">ESP023470P-15</a>
USPD 6068	3/16" (4.7) Tempered	5/16" (8.0)	1/4" (6) Lami	31	28		<a href="#">ESP023470P-17</a>
USPD 6068	1/4" (5.7) Tempered	5/16" (8.0)	1/4" (6) Lami	31	28		<a href="#">ESP023470P-13</a>
USPD 6068	1/4" (6) Lami	9/32" (7.0)	1/4" (6) Lami	32	29		<a href="#">ESP023470P-16</a>
USPD 6068	1/8" (3.1) Tempered	5/16" (8.0)	5/16" (7.8) Lami	31	28	Not NFRC-certified	<a href="#">ESP023470P-22</a>
USPD 6068	5/32" (3.9) Tempered	5/16" (8.0)	5/16" (7.8) Lami	31	28	Not NFRC-certified	<a href="#">ESP023470P-21</a>
<b>Ultimate Sliding French Door</b>							
USFD 6068	1/8" (3.1) Tempered	1/2" (13.0)	1/8" (3.1) Tempered	30	26		<a href="#">ESP023470P-1</a>
USFD 6068	1/8" (3.1) Tempered	7/16" (11.5)	3/16" (4.7) Tempered	31	27		<a href="#">ESP023470P-10</a>
USFD 6068	1/8" (3.1) Tempered	3/8" (9.8)	1/4" (5.7) Tempered	31	28		<a href="#">ESP023470P-5</a>
USFD 6068	5/32" (3.9) Tempered	7/16" (11.5)	5/32" (3.9) Tempered	30	27		<a href="#">ESP023470P-7</a>
USFD 6068	1/4" (5.7) Tempered	5/16" (8.0)	1/4" (5.7) Tempered	31	28		<a href="#">ESP023470P-11</a>
USFD 6068	1/8" (3.1) Tempered	3/8" (9.8)	1/4" (6) Lami	32	28		<a href="#">ESP023470P-3</a>
USFD 6068	3/16" (4.7) Tempered	5/16" (8.0)	1/4" (6) Lami	32	29		<a href="#">ESP023470P-8</a>
USFD 6068	1/4" (5.7) Tempered	5/16" (8.0)	1/4" (6) Lami	32	29		<a href="#">ESP023470P-9</a>
USFD 6068	1/4" (6) Lami	9/32" (7.0)	1/4" (6) Lami	31	29		<a href="#">ESP023470P-2</a>
USFD 6068	1/8" (3.1) Tempered	5/16" (8.0)	5/16" (7.8) Lami	32	29	Not NFRC-certified	<a href="#">ESP023470P-4</a>
USFD 6068	5/32" (3.9) Tempered	5/16" (7.5)	5/16" (7.8) Lami	32	29	Not NFRC-certified	<a href="#">ESP023470P-6</a>
<b>Ultimate Sliding French Door IZ3</b>							
USFD 6068	5/32" (3.9) Tempered	5/16" (8.0)	9/32" (6.9) SGP LAMI	32	29	IZ	<a href="#">ESP023470P-23</a>
USFD 6068	3/16" (4.7) Tempered	9/32" (7.0)	9/32" (6.9) SGP LAMI	32	29	IZ	<a href="#">ESP023470P-24</a>

**STC and OITC Class Values**

Marvin Sound Transmission Class and Outdoor - Indoor Transmission Class Values							
Product Type	Exterior Glazing	Airspace	Interior Glazing	STC	OITC	Additional Information	STC Report #
Ultimate Outswing French Door							
Ultimate Multi-Slide Door / Stacked							
Multi Panel Sliding Door CN6070 OX	3/16" (4.7) Tempered	9/16" (14.5)	3/16" (4.7) Tempered	30	27		<a href="#">ESP021984P-1</a>
Multi Panel Sliding Door CN6070 OX	3/16" (4.7) Tempered	1/2" (13.0)	1/4" (5.7) Tempered	32	29		<a href="#">ESP021984P-3</a>
Multi Panel Sliding Door CN6070 OX	1/4" (5.7) Tempered	7/16" (11.5)	1/4" (5.7) Tempered	31	28		<a href="#">ESP021984P-4</a>
Multi Panel Sliding Door CN6070 OX	3/16" (4.7) Tempered	1/2" (13.0)	1/4" (6.0) Lami	33	30		<a href="#">ESP021984P-5</a>
Multi Panel Sliding Door CN6070 OX	1/4" (6.0) Lami	7/16" (11.5)	1/4" (6.0) Lami	33	30		<a href="#">ESP021984P-2</a>
Multi Panel Sliding Door CN6070 OX	3/16" (4.7) Tempered	1/4" (11.5)	11/32" (8.6) SGP	31	29	IZ3	<a href="#">ESP021984P-7</a>
Multi Panel Sliding Door CN6070 OX	1/4" (5.7) Tempered	1/2" (13.0)	15/32" (11.7) SGP	32	30	IZ3	<a href="#">ESP021984P-6</a>
Ultimate Sliding Door 2 1/4" (3" stiles) (USD, USFDG2)							
Ultimate Sliding Door CN6070 OX	3/16" (4.7) Tempered	5/16" (8.0)	3/16" (4.7) Annealed	30	25	Tripane: two 5/16" air spaces with 1/4" PVB center pane	<a href="#">ESP040307P-1</a>
Ultimate Sliding Door CN6070 OX	7/32" (5.7) Tempered	15/32" (11.5)	1/4" PVB (6.0) Lami	32	28		<a href="#">ESP040307P-5</a>
Ultimate Sliding Door CN6070 OX	3/16" (4.7) Tempered	17/32" (13.0)	1/4" PVB (6.0) Lami	31	28		<a href="#">ESP040307P-3</a>
Ultimate Sliding Door CN6070 OX	7/32" (5.7) Tempered	17/32" (13.0)	7/16" PVB (11.7) Lami	33	30		<a href="#">ESP040307P-2</a>
Ultimate Sliding Door CN6070 OX	5/32" (3.9) Lami	5/8" (16.0)	5/32" (3.9) Lami	29	25		<a href="#">ESP040307P-6</a>
Ultimate Sliding Door CN6070 OX	3/16" (4.7) Tempered	13/32" (9.8)	5/16" PVB (8.6) Lami	32	29		<a href="#">ESP040307P-7</a>
Ultimate Inswing/Outswing Doors (3" stiles) (UID, UOD, UIFDG2, UOFDG2)							
Ultimate Inswing Door 2.25 CN6070	3/16" (4.7) Annealed	5/16" (8.0)	3/16" (4.7) Tempered	32	27	Tripane: two 5/16" air spaces with 1/4" PVB center pane	<a href="#">ESP037485P-6</a>
Ultimate Inswing Door 2.25 CN6070	7/32" (5.7) Tempered	15/32" (11.5)	1/4" PVB (6.0) Lami	34	30		<a href="#">ESP037485P-5</a>
Ultimate Inswing Door 2.25 CN6070	3/16" (4.7) Annealed	17/32" (13.0)	1/4" PVB (6.0) Lami	34	30		<a href="#">ESP037485P-4</a>
Ultimate Inswing Door 2.25 CN6070	7/32" (5.7) Tempered	17/32" (13.0)	7/16" PVB (11.7)	36	32		<a href="#">ESP037485P-2</a>
Ultimate Inswing Door 2.25 CN6070 IZ3	3/16" (4.7) Annealed	13/32" (9.8)	5/16" PVB (8.6) Lami	33	30	IZ3	<a href="#">ESP037485P-3</a>
Ultimate Inswing Door 2.25 CN6070	5/32" (3.9) Lami	5/8" (16.0)	5/32" (3.9) Lami	32	27		<a href="#">ESP036503P-4</a>

NOTE: The test results for the Ultimate Inswing 2 1/4" Door covers the Ultimate Outswing 2 1/4" Door as well.  
 The test results for the 3" stile doors (Sliding and Swinging) covers the French Door G2 products as they would perform slightly better.

**ENERGY STAR® Program - United States**

[www.energystar.gov](http://www.energystar.gov)

**About ENERGY STAR®**

ENERGY STAR® is a program of the U.S. Environmental Protection Agency helping us all save money and protect the environment through energy efficient products and practices.

Residential Windows, Doors and Skylights

Thanks to advances in technology, today's ENERGY STAR® certified windows, doors, and skylights offer greater savings than ever before. Just look for the ENERGY STAR® label.

**Save energy and money.**

Replacing old windows with ENERGY STAR® certified windows lowers household energy bills by 7-15 percent. Lower energy consumption also reduces greenhouse gas emissions from power plants and shrinks a house's carbon footprint.

**Current Specification Effective Date: October 23, 2023**

As of October 23, 2023, ENERGY STAR® certified windows, doors, and skylights meet new performance levels, see below.

Windows and skylights must meet NFRC U-Factor and, where applicable, Solar Heat Gain Coefficient (SHGC) requirements based on climate zone. Doors must meet U-Factor and, where applicable, SHGC requirements based on glazing level (amount of glass).

At this time, many Marvin product lines are certified for the ENERGY STAR® program. For more specific information, please refer to the individual product sections in your Marvin catalog.

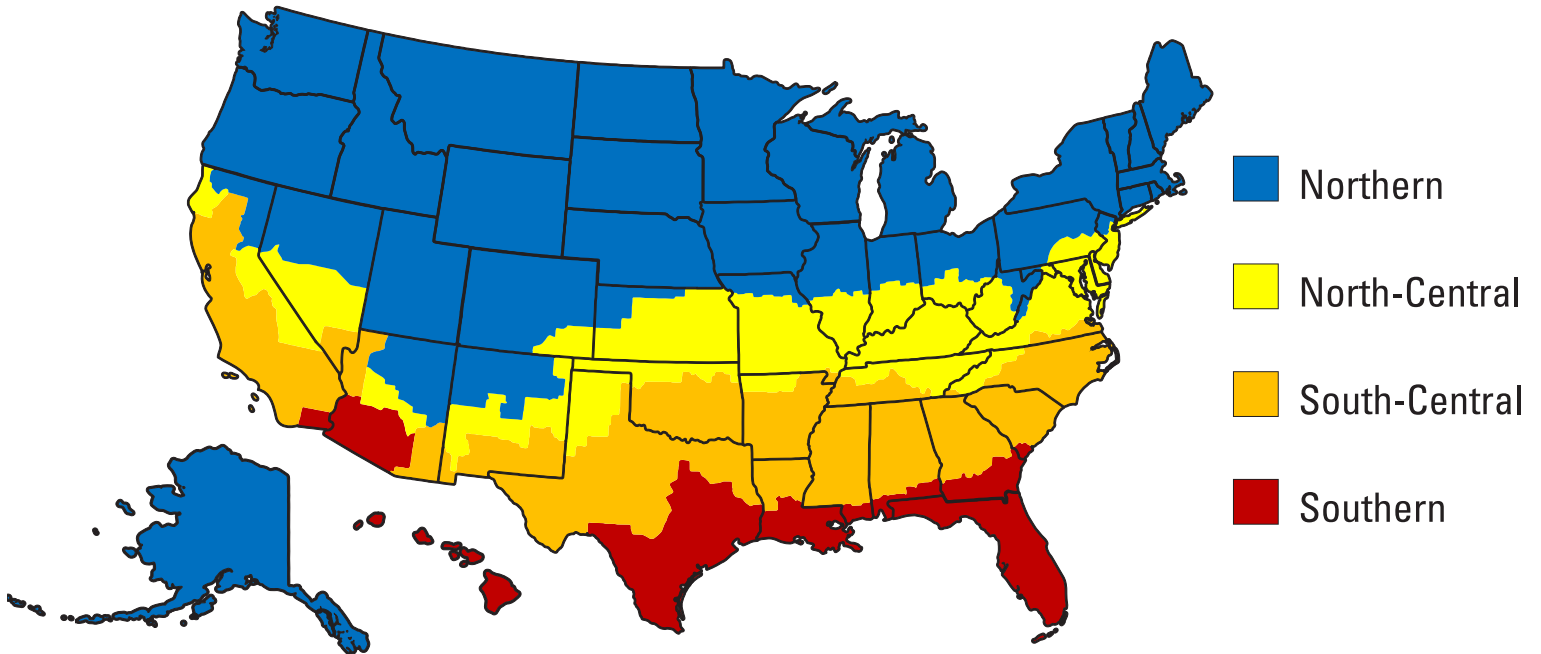

**ENERGY STAR® Program - United States**

[www.energystar.gov](http://www.energystar.gov)

WINDOWS			
Climate Zone	U-Factor <sup>1</sup>	SHGC <sup>2</sup>	
<b>Northern</b>	≤ 0.22	≥ 0.17	Prescriptive
	= 0.23	≥ 0.35	Equivalent Energy Performance
	= 0.24		
	= 0.25	≥ 0.40	
	= 0.26		
<b>North-Central</b>	≤ 0.25	≤ 0.40	
<b>South-Central</b>	≤ 0.28	≤ 0.23	
<b>Southern</b>	≤ 0.32	≤ 0.23	

Air Leakage ≤ 0.3 cfm/ft<sup>2</sup>  
<sup>1</sup> Btu/h-ft<sup>2</sup>·°F  
<sup>2</sup> Solar Heat Gain Coefficient

DOORS			
Glazing Level	Climate Zone	U-Factor <sup>1</sup>	SHGC <sup>2</sup>
Opaque	All Zones	≤ 0.17	No Rating
≤ ½-Lite	All Zones	≤ 0.23	≤ 0.23
> ½-Lite	<b>Northern</b>	≤ 0.26	≤ 0.40
	<b>North-Central</b>		
	<b>South-Central</b>	≤ 0.28	≤ 0.23
	<b>Southern</b>		

Air Leakage for Sliding Doors ≤ 0.3 cfm/ft<sup>2</sup>  
 Air Leakage for Swinging Doors ≤ 0.5 cfm/ft<sup>2</sup>  
<sup>1</sup> Btu/h-ft<sup>2</sup>·°F  
<sup>2</sup> Solar Heat Gain Coefficient

Skylights		
Climate Zone	U-Factor <sup>1</sup>	SHGC <sup>2</sup>
<b>Northern</b>	≤ 0.45	Any
<b>North-Central</b>	≤ 0.50	≤ 0.25
<b>South-Central</b>		
<b>Southern</b>		

Air Leakage ≤ 0.3 cfm/ft<sup>2</sup>

**ENERGY STAR® Most Efficient - United States**

The ENERGY STAR® Most Efficient mark is an extension of the ENERGY STAR® brand and is designed to recognize and advance the most efficient products among those that qualify for ENERGY STAR®. This recognition is for specific categories and awarded for a specific year.

Marvin has long been a leader in providing our customers with energy efficient options. We are pleased to announce that Marvin meets the US ENERGY STAR® Most Efficient criteria with over 40 product types and 27,000+ glazing options.

**MOST EFFICIENT CRITERIA**

<b>Climate Zone</b>	<b>U-factor</b>	<b>SHGC</b>
<b>Northern</b>	$\leq 0.20$	$\geq 0.20$
<b>North-Central</b>	$\leq 0.20$	$\leq 0.40$
<b>South-Central</b>	$\leq 0.20$	$\leq 0.23$
<b>Southern</b>	$\leq 0.21$ $= 0.22$	$\leq 0.23$ $\leq 0.21$

As more product and glazing options are certified throughout the year, additional qualifying options will become available. The EPA has set up a page on its website where consumers can go to find all of the Marvin options that meet the Most efficient criteria.

To view the latest listing of Most Efficient-qualifying products, click [here](#).



## ENERGY STAR® Program - Canada

This technical specification determines how residential windows, doors, and skylights sold in Canada are certified for the ENERGY STAR® program. This specification is issued by Natural Resources Canada (NRCan). NRCan has been authorized by the U.S. Environmental Protection Agency (EPA) to promote and administer the ENERGY STAR name and symbol in Canada. A product must meet this specification in order to be promoted as ENERGY STAR certified in Canada by its manufacturer or authorized agent. Manufacturers must also sign a Fenestration Administrative Arrangement with NRCan.

### Performance metrics

**U-Factor:** The heat transfer per time per area and per degree of temperature difference in  $W/m^2 \cdot K$  ( $Btu/h \cdot ft^2 \cdot ^\circ F$ ). The U-factor multiplied by the interior-exterior temperature difference and by the projected fenestration product area yields the total heat transfer through the fenestration product due to conduction, convection, and long-wave infra-red radiation. A U-factor in  $Btu/h \cdot ft^2 \cdot ^\circ F$  multiplied by 5.678263 converts the value to  $W/m^2 \cdot K$ . The U-factor in  $Btu/h \cdot ft^2 \cdot ^\circ F$  shall conform with Table 1 before the conversion to  $W/m^2 \cdot K$ .

**Solar heat gain coefficient (SHGC):** The ratio of the solar heat gain entering the space through the fenestration product to the incident solar radiation.

**Air leakage:** the flow of air that passes through fenestration products in  $L/s/m^2$ . Air leakage infiltration is the flow of air into the building envelope and exfiltration is the flow of air out of the building envelope. An air leakage in  $cfm/ft^2$  multiplied by 5.08 converts the value to  $L/s/m^2$ . The air leakage value in  $cfm/ft^2$  shall conform with Table 1 before the conversion to  $L/s/m^2$ .

**Energy rating (ER):** a unitless value derived from a formula that balances heat loss (U-factor), air leakage loss and potential passive solar gain of a fenestration product. The ER is applied to fenestration systems intended to be installed in a vertical orientation in low-rise residential buildings. The simplified ER equation is as follows:

$$ER = (57.76 \times SHGC_w) - (21.90 \times U_w) - (1.97 \times L_{75}) + 40 \text{ where}$$

- i.  $SHGC_w$  = fenestration system solar heat gain coefficient
- ii.  $U_w$  = fenestration system U-factor ( $W/m^2$ )
- iii.  $L_{75}$  = fenestration system air leakage rate at a pressure difference of 75 Pa, established in accordance with AAMA/WDMA/CSA 101/I.S.2/A440 (North American Fenestration Standard) in  $L/s \cdot m^2$ . The  $L_{75}$  shall be the average of the infiltration and exfiltration measurements.

A complete explanation of the ER equation may be found in the CSA A440.2 Standard.

### U-factor Criteria for Residential Windows and Doors

Product	Maximum U-factor $W/m^2 \cdot K$	Maximum U-factor $Btu/h \cdot ft^2 \cdot ^\circ F$
Windows and Doors	1.22	0.21

### Alternate ER Criteria for Residential Windows and Doors

Product	Minimum ER (unitless)
Windows and Doors	34

### U-factor Criteria for Unit Skylights

Product	Maximum U-factor $W/m^2 \cdot K$	Maximum U-factor $Btu/h \cdot ft^2 \cdot ^\circ F$
Skylights	2.29	0.4

**Air Leakage requirements:** Fenestration models must have an air infiltration rate and an air exfiltration rate less than or equal to 1.5  $L/s/m^2$ .

Marvin options that meet the ENERGY STAR Canada criteria can be viewed in the NRCan listing for [NRCan ENERGY STAR Searchable Product List](#).



**ENERGY STAR® Most Efficient - Canada****Most Efficient criteria for windows and sliding glass doors 2023**

The window or sliding glass door must:

- be manufactured by an ENERGY STAR Canada Participant
- be sold in Canada, registered with NRCan as ENERGY STAR certified and posted on the Canada/NRCan website
- meet the labeling section of the *Guidelines for the labeling and promotion of ENERGY STAR certified fenestration products*
- meet the following specific criteria:
  - A U-factor of  $1.05 \text{ W/m}^2\cdot\text{K}$  ( $0.18 \text{ Btu/h}\cdot\text{ft}^2\cdot^\circ\text{F}$ ) or lower**OR**
  - An Energy Rating (ER) of 40 (unitless) or higher

Marvin options that meet the Most efficient criteria can be viewed in the NRCan listing for [NRCan Most Efficient Windows and Sliding Glass Doors](#).



**ENERGY STAR® Program**

Today, manufacturers use an *array of technologies* to make ENERGY STAR qualified windows.

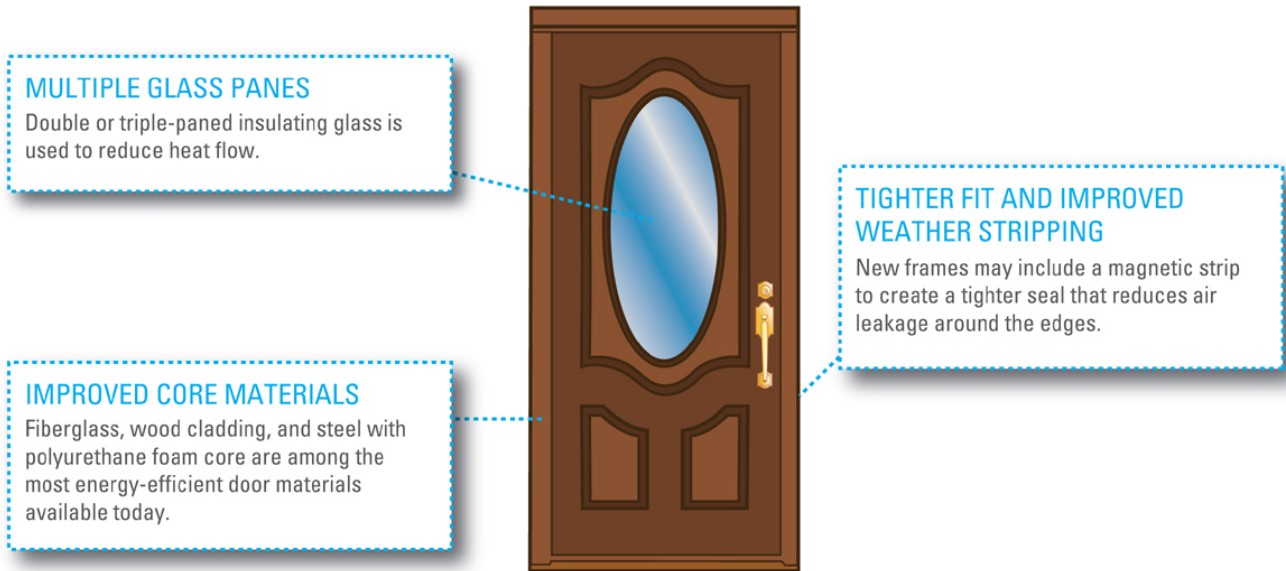
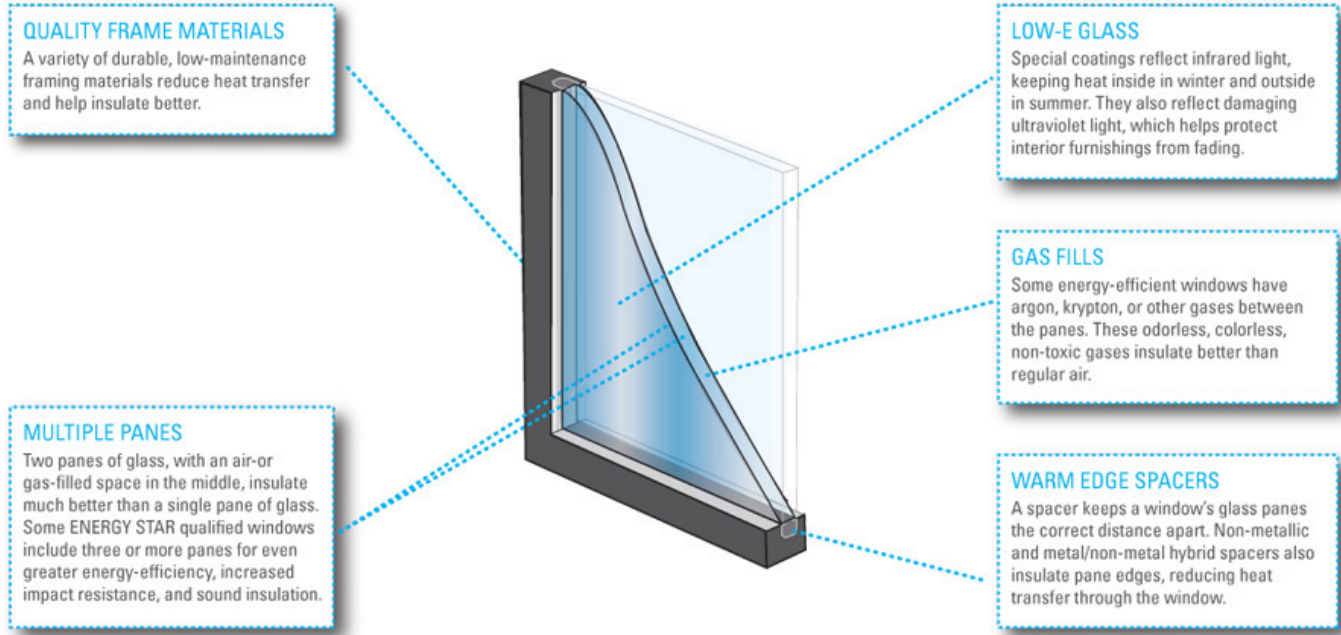

## **NFRC Certification Program**

### **Who is the NFRC?**

The National Fenestration Rating Council (NFRC) is a non-profit public/private group of manufacturers, builders, designers, specifiers, code officials, utilities, regulators and consumers formed to establish a national energy performance rating system for fenestration products.

Sanctioned by the federal government under the Energy Policy Act of 1992, NFRC will, over the next several years, in addition to U-Factor (thermal transmission), rate other factors, including solar heat gain, optical properties, air infiltration and condensation resistance.

It is important to note that the NFRC is not setting minimum performance standards or mandating specific performance levels. NFRC has established a single rating system with a rigorous process for comparing product performance. By certifying and labeling their products in accordance with the NFRC program, manufacturers demonstrate their commitment to provide accurate energy performance information.

### **Whole Product Performance**

NFRC ratings are based on “whole product performance”. Although a window, door, or skylight may have high performance glazing, its overall performance may be reduced by a poorly performing frame. Similarly, a very energy efficient frame may be wasted on ineffective glazing and sealing. Whole product performance helps builders and consumers compare products of different construction and attributes directly.

When reading a NFRC Label, it is important to remember that the U-Factor, SHGC, and VT, values represent the whole window, not the center-of-glass

### **NFRC Labeling**

#### Certification and Labeling Process

Window and door manufacturers attempting to certify their fenestration products are required to have them evaluated by two different types of independent NFRC accredited laboratories.

1. The first type of laboratory is a computer simulation lab which evaluates a window or door's thermal efficiency by computer simulation programs. The computer program takes into account the product's frame and glazing system attributes and derives an overall product U-Factor.
2. The second type of laboratory is a physical testing laboratory which takes an actual product and evaluates it in a thermal chamber. The physical test lab will also derive an overall product U-Factor.

*For additional regional information, please contact your local Marvin Windows and Doors representative.*

*For complete NFRC ratings, please visit <http://pros.marvin.com/resources/architectural-detail-manual/>*

NFRC Label

**MARVIN**  SIGNATURE COLLECTION

ENERGY STAR® Certified in Highlighted Regions



ENERGY STAR

**UL CSMNT**  
**WA/WA**  
**Casement**  
**3/4" IG Low E2 Arg**  
**3.1mm 272 / 13.0mm arg / 3.1mm clr**  
**.006 SS - D Pine or EQU**  
**MAR - N - 342 - 13243 - 00001**

**ENERGY PERFORMANCE RATINGS**

U-Factor <b>0.29</b> (U.S.I.-P)	SOLAR HEAT GAIN COEFFICIENT <b>0.29</b>
---------------------------------------	--

**ADDITIONAL PERFORMANCE RATINGS**

VISIBLE TRANSMITTANCE <b>0.49</b>	
--------------------------------------	--

Manufacturer stipulates that these ratings conform to applicable NFRC procedures for determining whole product performance. NFRC ratings are determined for a fixed set of environmental conditions and a specific product size. NFRC does not recommend any product and does not warrant the suitability of any product for any specific use. Consult manufacturers literature for other product performance information. www.nfrc.org

**Ultimate Casement**  
**Manufacturer Stipulates Hallmark Certification As Indicated Below**

UNIT	
Hallmark Product Number	407 - H - 918
AAMA/WDMA/CSA 1011A.5.2/A440-08	CW - PG50 914X2442 mm (36X96 13 in)
POSITIVE DESIGN PRESSURE (DP)	+50 psf
NEGATIVE DESIGN PRESSURE (DP)	-50 psf
Water Penetration Test Pressure	7.5 psf
MULL	
Hallmark Product Number	407 - H - 1137
AAMA 450 - 10 Option 1	
POSITIVE DESIGN PRESSURE (DP)	+70 psf
NEGATIVE DESIGN PRESSURE (DP)	-70 psf

OVERALL RATING  
CW - PG50  
WATER RESISTANCE 10.65 psf

**TCL02216 1 A1**

Do Not Remove this label prior to inspection.  
Save for future reference

Energy Star

NFRC

WDMA

**Building Categories and Design Factors**

Design Wind Pressure (PSF) - ASCE 7 -05												
Location	Zone	Effective Wind Area (SF)	Basic Wind Speed V (MPH)									
			110		115		120		130		140	
Walls	4	10	+22	-24	+24	-26	+26	-28	+30	-33	+35	-38
		50	+20	-21	+21	-23	+23	-25	+27	-30	+32	-35
		500	+16	-18	+18	-20	+19	-22	+23	-25	+26	-29
			150		160		180		200			
		10	+41	-44	+46	-50	+58	-63	+72	-78		
		50	+36	-40	+41	-45	+52	-57	+64	-71		
		500	+30	-34	+34	-38	+44	-48	+54	-60		
Walls	5		110		115		120		130		140	
		10	+22	-29	+24	-32	+26	-35	+30	-41	+35	-47
		50	+20	-25	+21	-27	+23	-29	+27	-34	+32	-40
		500	+16	-18	+18	-20	+19	-22	+23	-25	+26	-29
			150		160		180		200			
		10	+41	-54	+46	-62	+58	-78	+72	-96		
		50	+36	-46	+41	-52	+52	-66	+64	-81		
	500	+30	-34	+34	-38	+44	-48	+54	-60			

Metric Conversions: 1 PSF = 47.9 pascals

1 SF = 0.0929 SM

1 MPH = 0.447 M/S

**NOTE:**

- Design wind pressures above represent the net pressure (sum of external and internal pressures) applied normal to all surfaces.
- Values shown are for exposure B. For other exposures, multiply values shown by the following factor: exposure C: 1.40 and exposure D: 1.66
- Linear interpolation between values of tributary area is permissible.
- Values shown are for an importance factor I = 1.0. For other values of I, multiply values shown by I.
- Plus and minus signs signify pressure acting toward and away from the exterior surface, respectively.
- All component and cladding elements shall be designed for both positive and negative pressures shown in the table.
- Notation:
  - 10% of least horizontal dimension or 0.4 h, whichever is smaller, but not less than 40% of least horizontal dimension or 3 ft.
  - Mean roof height in feet (meters).

**BUILDING WIND LOADS**

*“The information presented is provided to simplify the determination of structural wind load requirements of ASCE 7-05. ASCE 7-05 may not have local precedence. Please refer to your local codes for design pressures that apply to your area.”*

ASCE 7-05 Design wind load tables are based on the following:

- Wind loads tables are based on Exposure B.
- Tributary area of the structural elements is less than or equal to 10 sq. ft.
- Does not apply to roof areas.
- Roof slope is greater than 10 degrees.
- Building is less than or equal to 30 feet tall.
- The building is completely enclosed, all windows and doors are designed to withstand full wind load.
- Applicable to components and cladding, which include windows and doors.

If the tributary area is greater than 10 sq. ft. or if the roof slope is less than 10 degrees, the design wind loads from this table may be conservative. However, if the building has openings in the elevation which may allow wind to pass through, the design values in the tables may be too low. For these cases, ASCE 7-05 should be consulted.

NOTE: Windows and doors designed to resist wind loading are not considered openings.

---

**Building Categories and Design Factors****EXPOSURES**

**Exposure B:** Urban and suburban areas, wooded areas, or other terrain with numerous closely spaced obstructions having the size of single family dwellings or larger. For buildings with a mean roof height of less than or equal to 30ft (9.1m). Exposure B shall apply where the ground surface roughness, as defined by Surface Roughness B, prevails in the upwind direction for a distance greater than 1,500ft (457m). For buildings with a mean roof height greater than 30ft (9.1m), Exposure B shall apply where Surface Roughness B prevails in the upwind direction for a distance greater than 2,600ft (792m) or 20 times the height of the building, whichever is greater.

**Exposure C:** Open terrain with scattered obstructions having heights generally less than 30 ft. (9.1 m). This category includes flat open country, grasslands. Shall apply for all cases where Exposures B or D do not apply.

**Exposure D:** Flat, unobstructed areas and water surfaces. This category includes smooth mud flats, salt flats, and unbroken ice. Shall apply where the ground surface roughness, as defined by Surface Roughness D, prevails in the upwind direction for a distance greater than 5,000ft (1,524m) or 20 times the building height, whichever is greater. Exposure D shall also apply where the ground surface roughness immediately upwind of the site is B or C, and the site is within a distance of 600ft (183m) or 20 times the building height, whichever is greater, from the Exposure D condition as defined in the previous sentence. For a site located in the transition zone between exposure categories, the category resulting in the largest wind forces shall be used.

**INSTRUCTIONS:**

- Determine the Basic Wind Speed (V) in mph from Design Wind Load Table based on the location of the building.
- Determine the Roof Height (h) of the building in feet. This is the mean height of the roof above the lowest grade adjacent to the building. Eave height may be used for roof slope of less than 10 degrees.
- Determine least width (B) of the building in feet. This is defined as the shortest distance between two parallel lines which contain the entire building floor plan.
- Determine high pressure outside corner loading zones (a) in feet from building illustration on following page.  $a = (0.10) \times (B)$  or  $a = (0.4) \times (h)$ , whichever is smaller, but not less than either  $(0.04) \times (B)$  or 3 feet (76).
- Determine design pressure from Design Pressure Table.
- All design pressure values are assumed for buildings with an importance Factor Category of II. See Design Factors chart on following page.
- If category III, IV is more appropriate then multiply the design pressure by the corresponding Design Factor - See Design Factor chart.

**Building Categories and Design Factors**

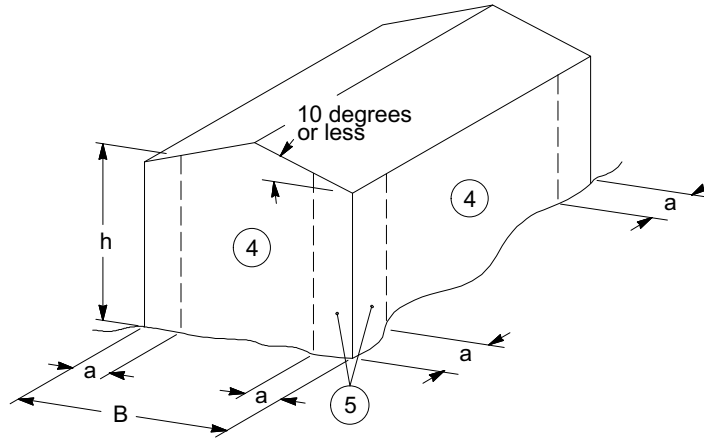

RISK CATEGORY	NATURE OF OCCUPANCY
I	Buildings and other structures that represent a low hazard to human life in the event of failure. <ul style="list-style-type: none"> <li>• Agricultural facilities.</li> <li>• Certain temporary facilities.</li> <li>• Minor storage facilities.</li> </ul>
II	Buildings and other structures except those listed in Risk Categories I, III and IV
III	<ul style="list-style-type: none"> <li>• Buildings and other structures that represent a substantial hazard to human life in the event of failure, such as, schools, colleges, large day care facilities, resident care recipients but not having surgery or emergency treatment facilities.</li> <li>• Any other occupancy with an occupant load greater than 5,000.</li> <li>• Power-generating stations, water treatment facilities for potable water, waste water treatment facilities, other public utility facilities, buildings and other structures containing quantities of toxic or explosive materials that exceed maximum allowable quantities per control area.</li> </ul>
IV	Buildings and other structures designated as essential facilities, such as, hospitals, surgery or emergency facilities. <ul style="list-style-type: none"> <li>• Fire, rescue, ambulance and police stations and emergency vehicle garages.</li> <li>• Designated earthquake, hurricane or other emergency shelters, emergency preparedness, communications and operations centers and other facilities required for emergency response.</li> <li>• Power-generating stations, public utility facilities required as emergency backup facilities.</li> <li>• Buildings/structures containing quantities of highly toxic materials.</li> <li>• Aviation control towers, air traffic control centers and emergency aircraft hangars.</li> <li>• Buildings and other structures having critical national defense functions.</li> <li>• Water storage facilities and pump structures required to maintain water pressure for fire suppression.</li> </ul>

*NOTE: This is an abbreviated version of the 2015 International Building Code (IBC) Table 1604.5. Please, check with your local building code official(s) for current requirements in your area.*

Category	Design Factors	
	Non-Hurricane prone regions and Hurricane prone regions with V = 85/100 mph and Alaska	Hurricane prone regions with V greater than 100 mph
I	0.87	0.77
II	1.00	1.00
III	1.15	1.15
IV	1.15	1.15

**Wind Speed Map - ASCE 7-16**

NOTES: Basic Wind Speeds for Occupancy Category II Buildings and Other Structures.

- Values are nominal design 3-second gust wind speeds in miles per hour (m/s) at 33ft (10m) above ground for Exposure C category.
- Linear interpolation between contours is permitted.
- Islands and coastal areas outside the last contour shall use the last wind speed contour of the coastal area.
- Mountainous terrain, gorges, ocean promontories, and special wind regions shall be examined for unusual wind conditions.
- Wind speeds correspond to approximately a 7% probability of exceedance in 50 years (Annual Exceedance Probability = 0.00143, MRI = 700 Years).

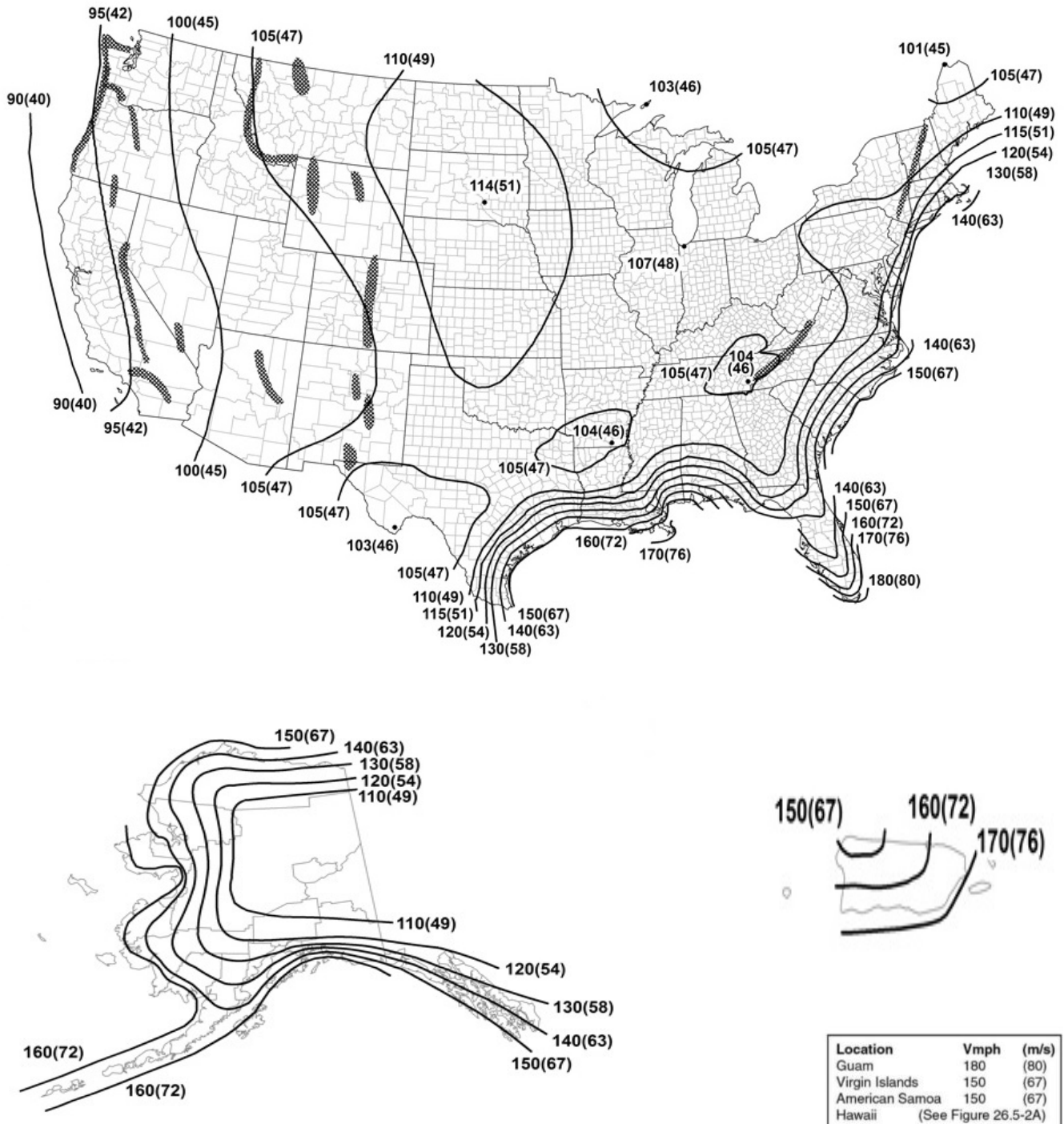



**Altitude Guidance**

Marvin provides Capillary Tube Usage Guidelines for all products, available upon request. Capillary tubes are also recommended in smaller lites or ADL units where one side of glass is less than 12" (305) in length at elevations of 3,000 feet or more above sea level. Partners who serve high altitude markets are expected to consult the Capillary Tube Usage Guidelines and make appropriate selections based on product size, installed altitude, and highest transportation altitude.