

Modern Structural Mulling

Assembly Instructions

ABSTRACT: The following instruction will demonstrate how to assemble Modern products using flat steel or tube steel for structural purposes. Refer to the installation instructions sent in the job box for procedures not shown here such as rough opening prep, additional fastening details, and flashing/sealing details.

USAGE DATES: This instruction is relevant for products manufactured December 2018 to present.

NOTE: Most illustrations within this instruction show units without nailing fin. This may differ from your preferred installation method. Remove any nailing fin from the frame where any mull will take place.

Table of Contents

- Hazard Notations and General Information 2
- Special Note on Sill Panning and Structural Mulls 2
- Window Flat Steel Mulling 3
- Window Tube Steel Mulling 20
- Swinging Door Flat Steel Mulling 45
- Swinging Door Tube Steel Mulling 57
- Tube Steel Mulling Procedures 59
- Final Installation Details 74
- Flashing Modern Window Installations 74

Hazard Notations and General Information

WARNING!

Always practice safety! Wear the appropriate eye, ear, and hand protection, especially when working with power tools.

WARNING!

Do NOT lift or move without proper equipment. Read, understand, and follow all lift equipment manufacturers' instructions and safety information.

CAUTION!

Wear gloves and protective clothing when handling the frame components. Some high-density fiberglass surfaces are not coated and can leave splinters in bare skin.

Hint

Sealants and/or structural sealants are included in the job box for use throughout this instruction. Use isopropyl alcohol to remove excessive wet sealants from the painted HDF material.

Special Note on Sill Panning and Structural Mulls

1. If the tube or flat steel interrupts the back dam/ upturned leg in your sill panning you will need to alter the panning to accommodate the structural member. Seal around the tube or flat steel after mulling is complete but before you install the interior mull cover. Seal in a manner so that incidental water cannot pass to the interior. [See Figure 1](#)



Figure 1

Window Flat Steel Mulling

Tools and Supplies Needed

- 1/2" x 4" (13 x 102) OR 1/2" x 2 1/2" (13 x 64) **primed** flat steel (spec listed below)
- 1/8" (3) drill bit for drilling into steel plate
- #23 drill bit (.154 inches or 3.911mm) for drilling into steel plate
- Power drill/driver
- Phillips head bit
- Drill stop collar
- Level
- Clamps
- Rubber mallet
- Tape Measure

- Scratch awl or tool for marking steel

Parts Included

- #8-32 x 1/2" trilobular screws (frame to steel)
- #8-32 x 1 1/4" trilobular screws (frame to steel for Casement only)
- #10-12 3" T20 Torx pan head 2/3 thread screws (through brackets into RO framing)
- Mull end brackets
- Mull covers
- Template for fabricating steel ends
- CSL 343 Sealant or equivalent

Steel Specification: ASTM A36/GR50 Steel or better.

IMPORTANT

If you are mulling a casement unit above another unit, when complete, you will need to fasten the hardware base to the mull using the 1 1/4" trilobular screws. See the [Special Instructions on Casement Units on page 42](#).

IMPORTANT

If you are mulling a polygon unit with a sloped head jamb or sill, [refer to Special Instructions for Non-Rectangular Polygons on page 43](#) for more details on using the correct mull brackets.

Fabricate Flat Steel Ends

1. Calculate the length of steel for the mull by taking the frame outside measurement and adding 1/8" (3). Cut the steel to this measurement. [See Figure 2](#).

2. Use the template included in the job box to mark and fabricate end cuts on the steel. [See Figure 3](#) and [Figure 4](#).

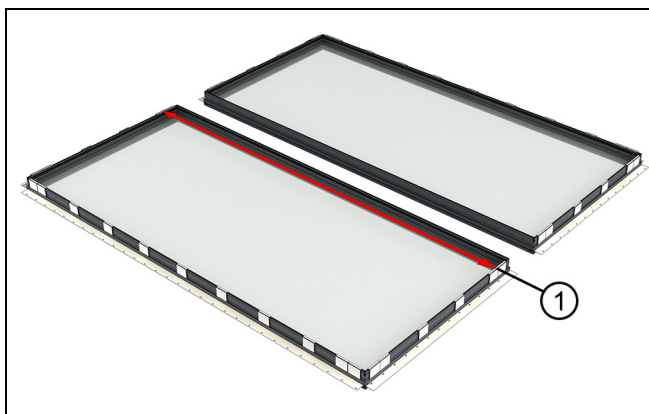

Figure 2

1	Measure full length of mull and add 1/8"
---	--

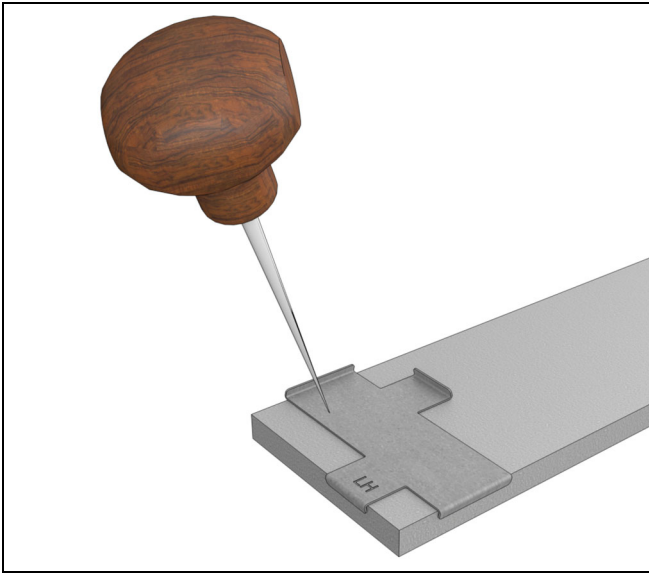

Figure 3

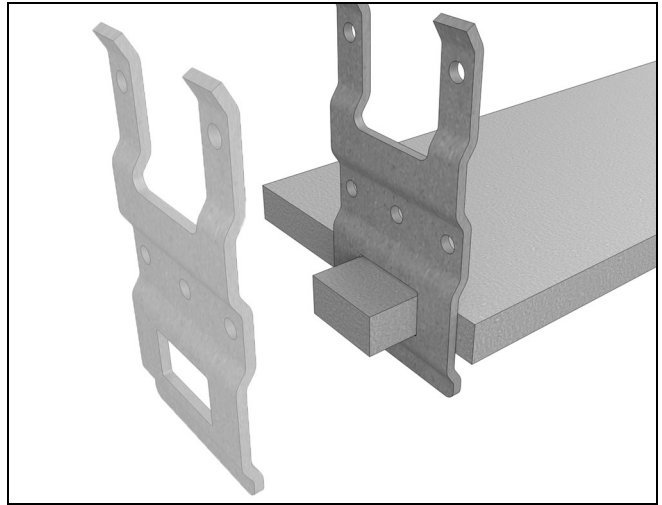

Figure 5

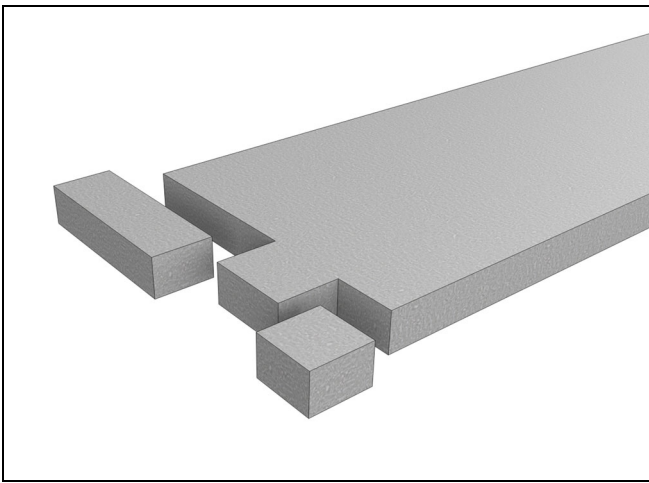

Figure 4

3. Dry-fit the mull bracket over the end of the steel to make sure the "tab" on the steel fits cleanly through the hole in the bracket. Adjust your cuts if necessary. [See Figure 5.](#)

Flat Steel-Ribbon Mulls Assembly and Installation

Using a smartphone or similar device, scan the QR code or go to the link below to play a video of this procedure.



<https://www3.marvin.com/download?vid=131>

This section will demonstrate mulling a two wide unit in the rough opening with a **vertical** mull. The procedure is similar for a horizontal mull. Repeat this process until your assembly is complete. See the [Flat Steel-Multiple Wide and Multiple High Assemblies on page 11](#) if your unit has both vertical and horizontal mulls. Refer to the installation instructions sent in the job box for fastening details.

IMPORTANT

For multiple high and multiple wide assemblies with mixed mull types (standard and structural) make sure to assemble the standard mull sub-assemblies first (refer to [Flat Steel-Multiple Wide and Multiple High Assemblies on page 11](#)).

1. Start with a flat and level opening.
2. Establish an exterior plane along the sill. Use a laser level or snap-line. This will be helpful for larger multiple wide assemblies. See [Figure 6](#).

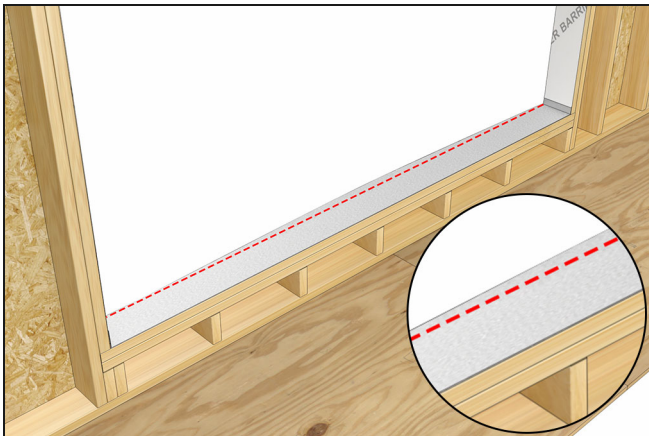

Figure 6



Hint

Remove any shim blocks along the mulls (if not already done from the factory). Also remove shim blocks from the top and bottom corners adjacent to the mull on units that will **not** have the steel attached to it first (in this case, the A2 unit). See [Figure 7](#) and [Figure 8](#).

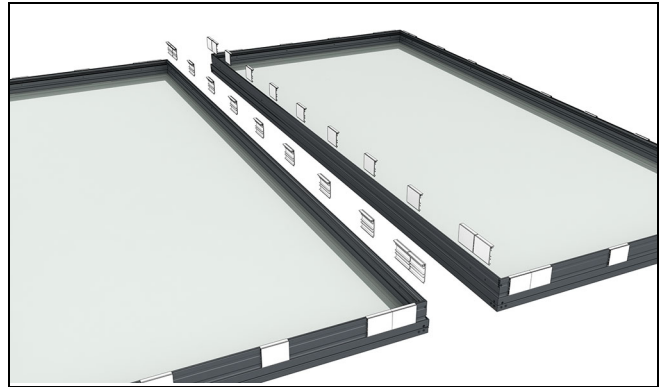

Figure 7

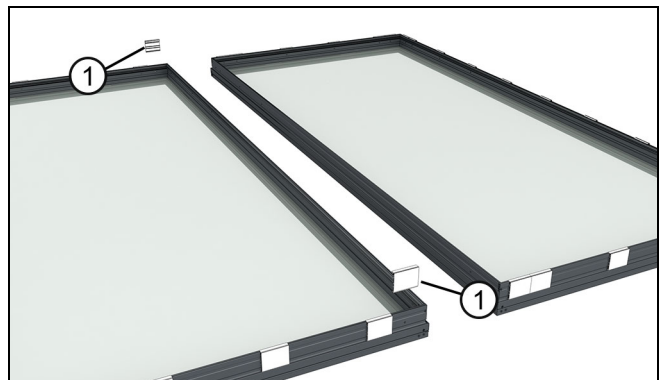

Figure 8

1	Shim blocks
---	-------------

IMPORTANT

Removing the shim blocks from the top and bottom corners will eliminate interference with the mull bracket later.

3. Position the first unit in the opening. Shim and plumb the first jamb on the desired vertical plane, then fasten with 3" installation screws. See [Figure 9](#).

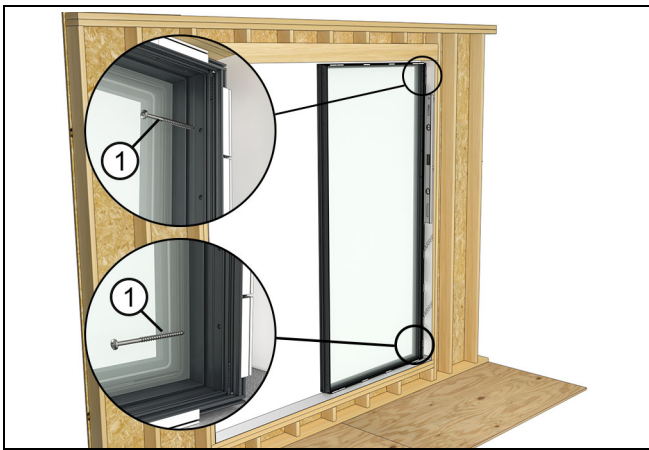

Figure 9

1	Installation screw
---	--------------------

4. Temporarily position the mull bracket on the sill. You will need shim to get the bracket to the correct height if the unit does not sit flat on the sill plate. The bracket should sit flush with the bottom of the frame/shim block. See Figure 10.

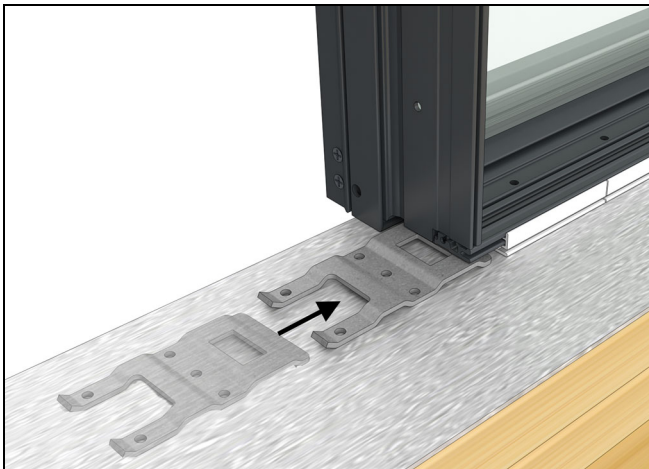

Figure 10

5. Position the steel tight against the step in the frame and so the tab on the mull steel fits in the hole in the sill bracket. Then clamp the steel to the frame. See Figure 11, Figure 12 and Figure 13.

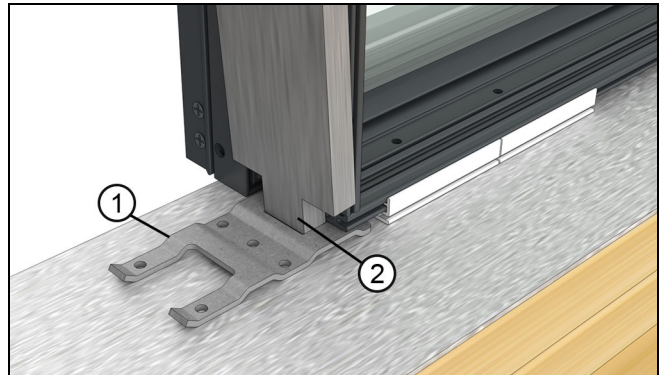

Figure 11

1	Mull bracket
2	"Tab" on steel set into the hole in the bracket



Figure 12

1	Steel fits tightly against the step in frame
---	--

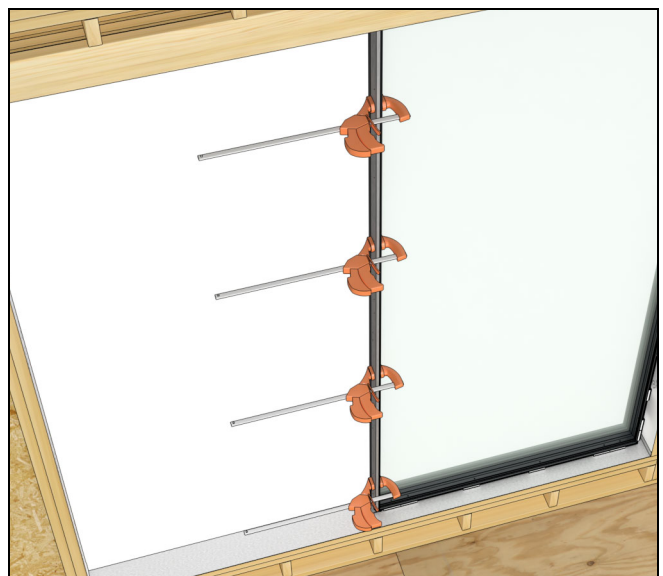

Figure 13

6. Adjust the frame and bracket so it is square in the opening. Fasten the bracket using #10-12 3" T20 Torx pan head 2/3 thread screws or similar depending on the sill material. See Figure 14 and Figure 15.

NOTE: If you are drilling into a sill pan or prepared sill with water management it is highly advised to pre-drill and inject sealant in the screw holes prior to fastening the sill bracket.

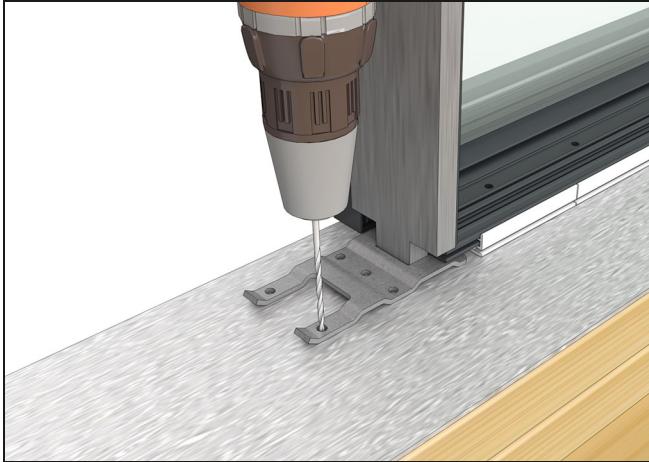

Figure 14

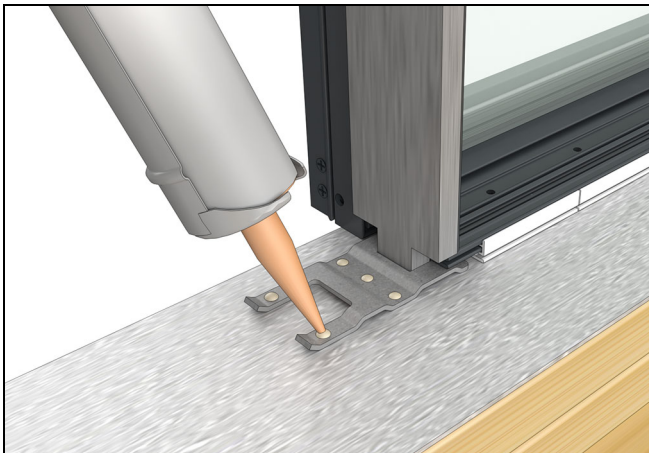

Figure 15

7. Slide the top mull bracket so that it fits over the tab on the mull steel. See Figure 16.

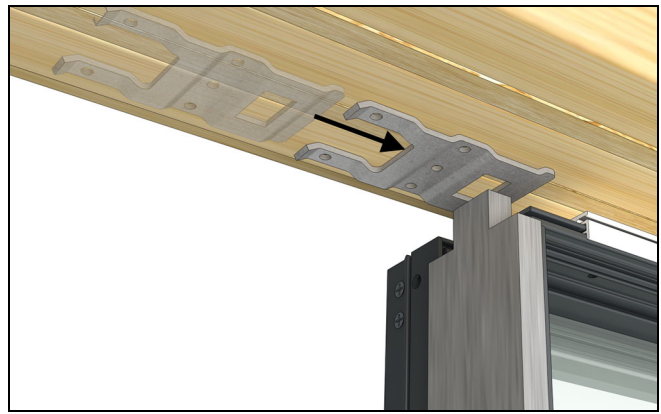

Figure 16

8. Shim the top bracket so that when it is fastened to the RO it will be no more than 1/8" away from the top of the frame/shim block. See Figure 17.



Figure 17

9. Fasten the top bracket to the RO with the 3" screws provided. See Figure 18.

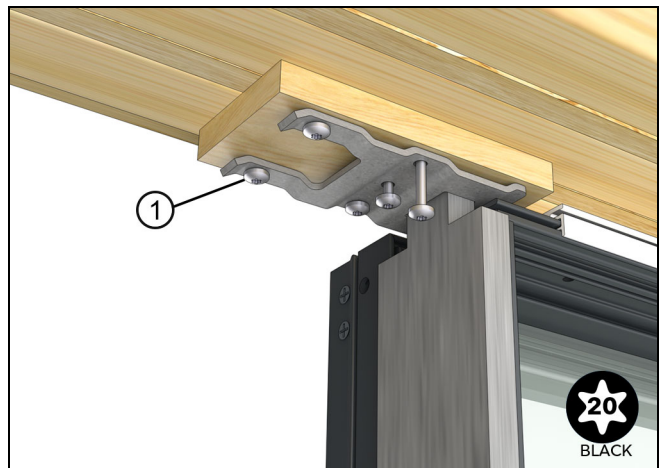

Figure 18

1	#10 x 3" Installation screw
---	-----------------------------

NOTE: You might have your own preference for screws depending on your steel of choice. Adjust the bit size in the next [step 10 on page 8](#)

10. Using the pre-drilled installation holes in the frame as a guide, drill through the steel with a #23 bit. See [Figure 19](#).

NOTE: You may need to first drill with a 1/8" bit.



Figure 19

1	#23 drill bit
2	Installation holes

11. Fasten the steel to the frame with the included #8-32 x 1/2" trilobular screws. See [Figure 20](#).



Figure 20

12. Apply a 1/4" bead of sealant beside the exterior frame accessory kerf along the entire length of the mull. See [Figure 21](#).

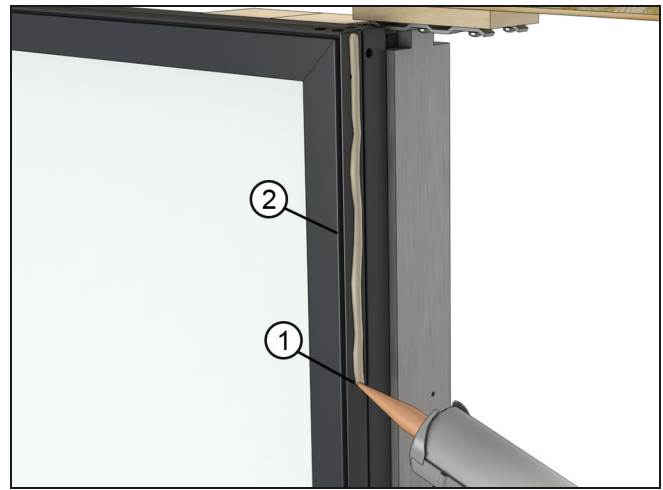

Figure 21

1	Sealant
2	Exterior accessory kerf

13. Set the second unit in place in the opening. Align the frames and clamp. See [Figure 22](#) and [Figure 23](#).

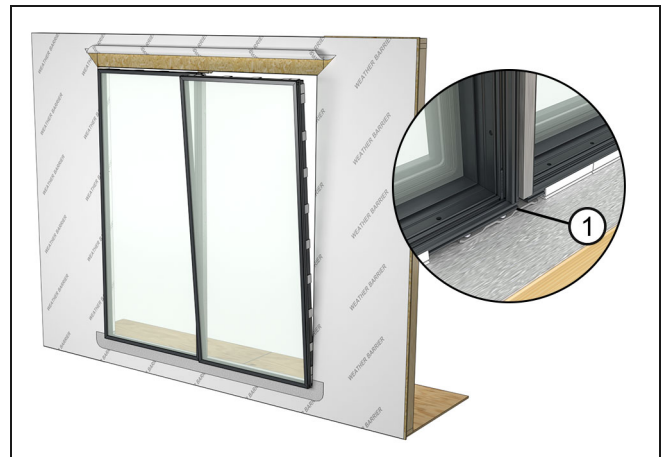

Figure 22 Set second unit and align frames (inset)

1	Align frames
---	--------------



Figure 23

IMPORTANT

Verify the sealant has made contact with both frames before proceeding.

14. Install the exterior mull cap. Seat in place with a rubber mallet. See Figure 24.

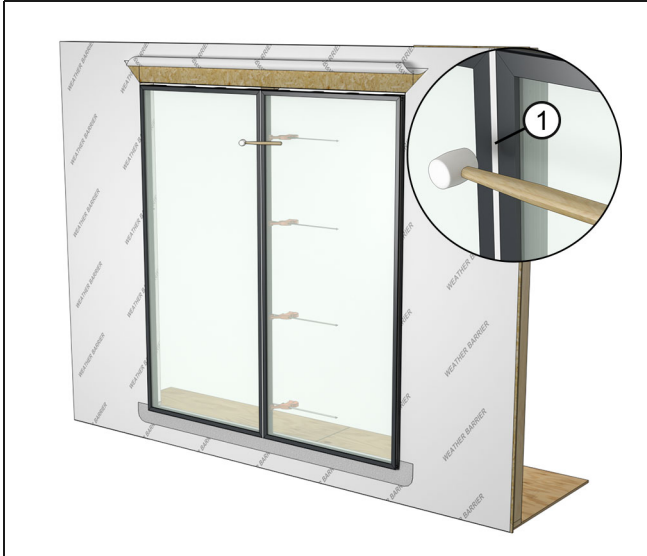

Figure 24

1	Mull cap
---	----------



Hint

Clean any excess sealant off the frame at this time.

IMPORTANT

Confirm that the installation holes on opposite sides of the mull are offset from each other (vertically). If not, drill new holes through the frame at least 1/2" away from the original installation holes.

15. Using a drill with a stop collar use the installation holes as a guide and bore into the steel with a #23 drill bit. Note the depth of the stop collar on Figure 25 for different products.

IMPORTANT

Do not bore through the steel and into the opposite framing.

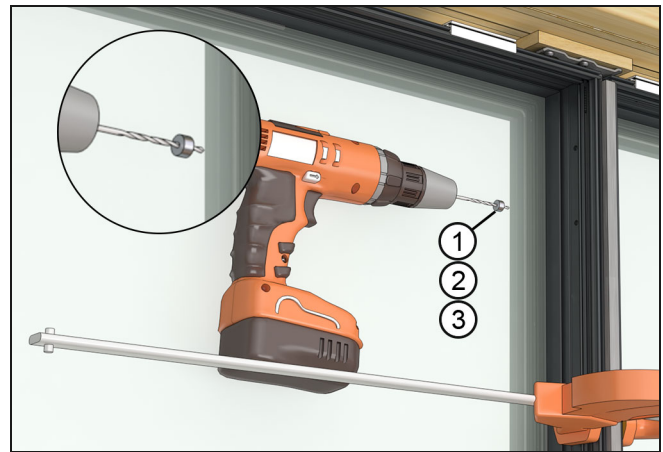

Figure 25

1	Direct Glaze: #23 drill bit with a stop collar set to 5/8" depth
2	Casement: #23 drill bit with stop collar set to 1 1/4" depth
3	Doors: #23 drill bit with stop collar set to 1" depth

16. Fasten the second frame to the mull steel using the #8 x 1/2" trilobular screws included. See Figure 26.



Figure 26

1	#8 x 1/2" Trilobular screws
---	-----------------------------

17. Making sure the second frame is aligned along the correct exterior plane, fasten the sill through pre-drilled holes in both frames. See Figure 27.

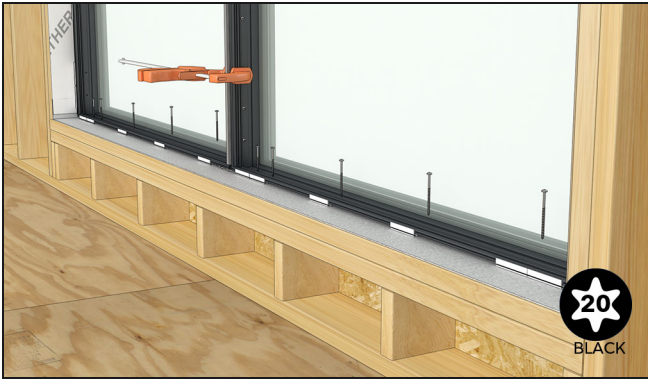

Figure 27

18. Square and plumb the second frame in the opening and then shim and fasten the jamb. See Figure 28.



Figure 28

19. Complete shimming and fastening around the entire perimeter using the pre-drilled installation holes. See Figure 29, Figure 30, and Figure 31.



Figure 29



Figure 30



Figure 31

Flat Steel-Multiple Wide and Multiple High Assemblies

The following steps will show a 2 wide 2 high configuration but would be similar for other multiple high multiple wide configurations. As a general rule mull any standard mulls first following the steps in the [Mulling Instructions](#), then proceed with the structural mull.

Frames are typically prepped from the factory for multiple wide/multiple high assemblies. In the event that the exterior frame kerf is not prepared from the factory, refer to the following steps to remove material from the corners of individual units where there is a cross section of mulls (i.e. the middle of a 2W2H configuration).

Using a smartphone or similar device, scan the QR code or go to the link below to play a video of this procedure.



<https://www3.marvin.com/download?vid=132>

1. For reference in this instruction, the illustrations will be showing a 2 wide 2 high assembly with the standard Marvin alphanumeric mulling labels as seen from the exterior. [See Figure 32.](#)



Figure 32

ATTENTION

If you have determined your frames are already prepped properly from the factory you can skip to [step 5 on page 12.](#)

2. Place the individual units on a flat sturdy surface exterior side up.

3. Place the individual units on a flat sturdy surface exterior side up. Use a hacksaw, rotary tool, or oscillating tool, to remove material from the corners of individual units to allow the mull cap to pass. Remove about 1/8" of material from the accessory kerf leg that runs perpendicular to the direction of the mull. [See Figure 33.](#)

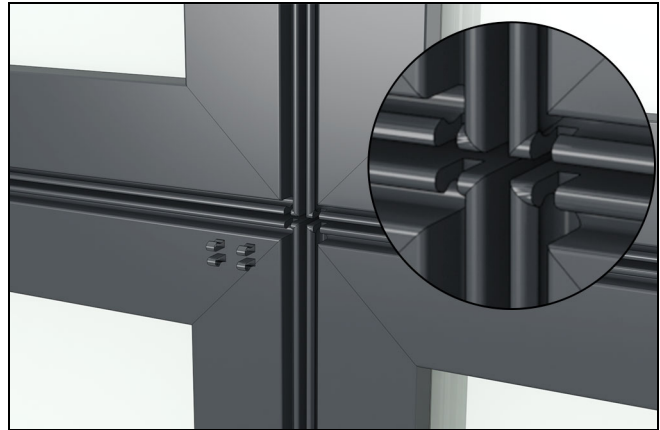

Figure 33

4. Remove any shim blocks along the mulls. Also remove shim blocks from the top and bottom corners adjacent to the mull on units that do not have the steel attached to first (in this case, the A2 unit). [See Figure 34](#) and [Figure 35.](#)

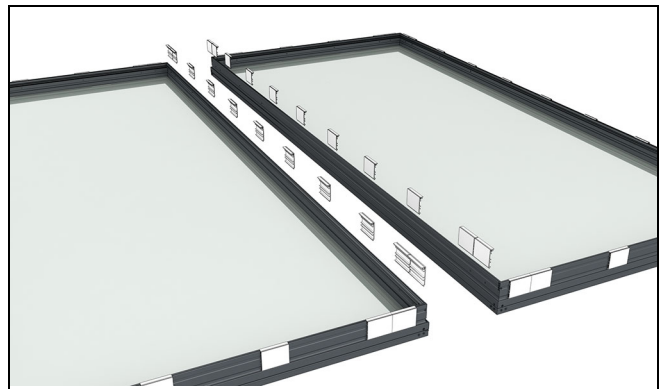

Figure 34

IMPORTANT

Removing the shim blocks from the top and bottom corners will eliminate interference with the mull bracket later.

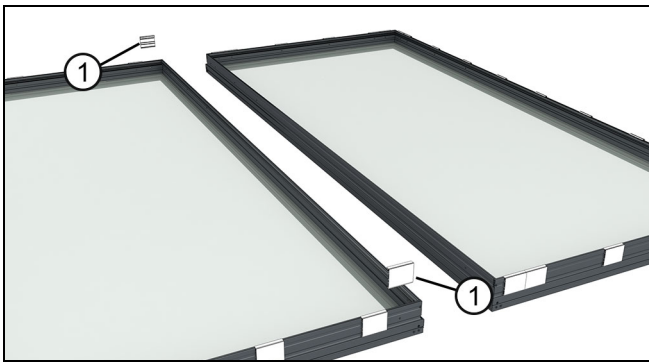

Figure 35

1	Shim blocks removed from A2
---	-----------------------------

5. Establish an exterior plane along the sill. Use a laser level or snap line. This will be helpful for larger multiple wide assemblies. See Figure 36.

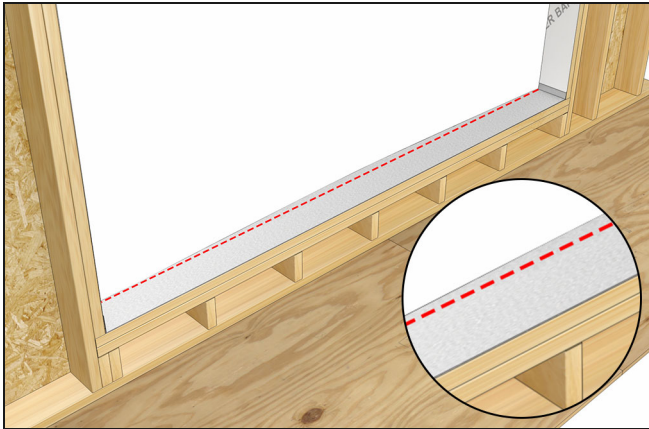

Figure 36

WARNING!

Do NOT lift or move without proper equipment. Read, understand, and follow all lift equipment manufacturers' instructions and safety information.

Hint

In some cases, it may be preferred to assemble a standard mull first, outside the rough opening, and then install that as one assembly before proceeding with the structural steel mull. The following illustrations show installing the assembly and mulling one unit at a time in the rough opening.

6. Set the first unit (B1) in the opening. See Figure 37.

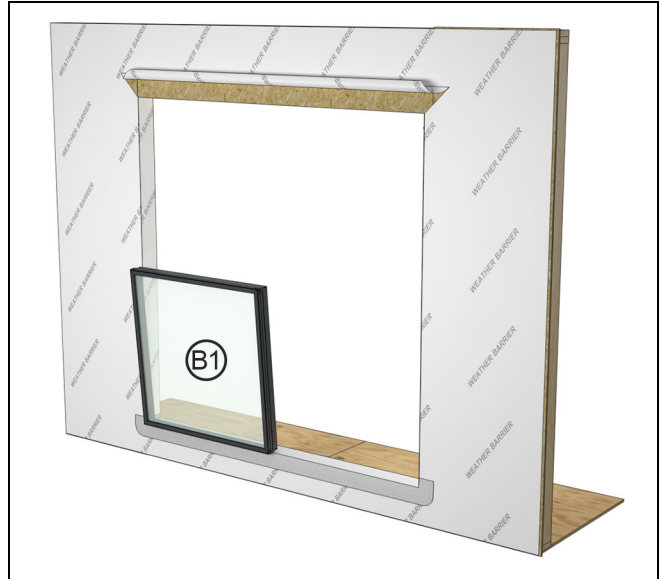

Figure 37

1	Unit B1 of the assembly
---	-------------------------

7. Plumb and square the B1 unit in the opening, then shim and pin the jamb. See Figure 38.



Figure 38

1	#10 x 3" T20 Torx screw
---	-------------------------

8. Mull the second unit (A1) to the first (B1). For standard tight mulls, follow procedures found in the [mull instructions](#). For structural or flat steel mulls, refer to the appropriate procedures within this instruction. See [Figure 39](#).

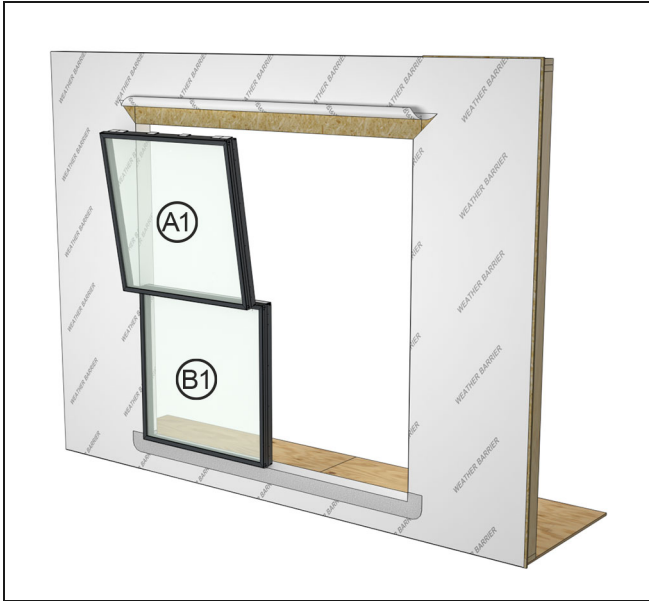

Figure 39

9. Once the B1 and A1 assembly is mull'd, square plumb and pin the jamb. See [Figure 40](#).



Figure 40

1	#10 x 3" T20 installation screw
---	---------------------------------

10. Install the exterior horizontal mull clip. See [Figure 41](#).

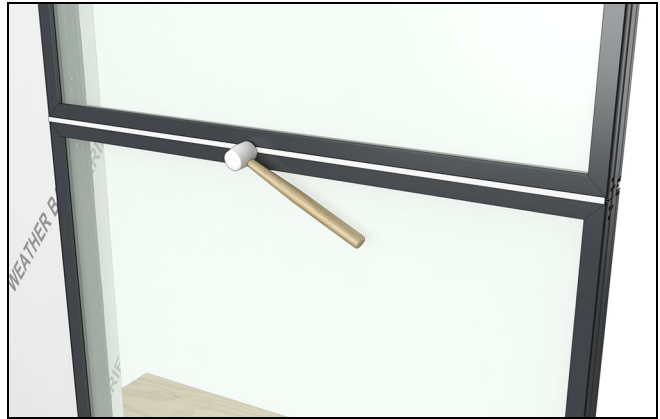

Figure 41

11. Temporarily position the mull bracket on the sill. You will need shim to get the bracket to the correct height if the unit does not sit flat on the sill plate. The bracket should sit flush with the bottom of the frame/shim block. See [Figure 42](#).

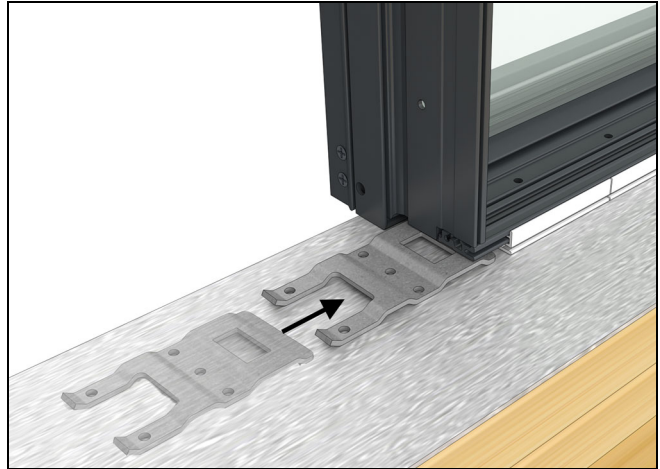

Figure 42

12. Position the steel tight against the step in the frame and so the tab on the mull steel fits in the hole in the sill bracket. Then clamp the steel to the frame. See [Figure 43](#), [Figure 44](#), and [Figure 45](#).

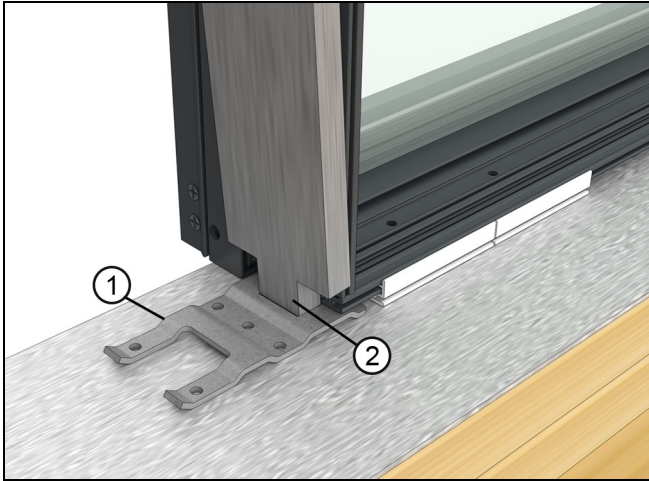

Figure 43

1	Mull bracket
2	"Tab" on steel set into the hole in the bracket

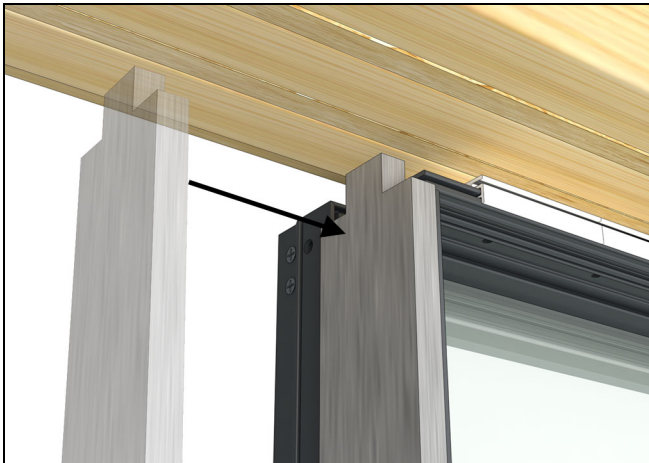

Figure 44

1	Steel fits tightly against the step in frame
---	--



Figure 45

13. Adjust the frame and bracket so it is square in the opening. Fasten the bracket to the sill using #10-12 3" T20 Torx pan head 2/3 thread screws or similar depending on the sill material. See [Figure 46](#) and [Figure 47](#).

NOTE: If you are drilling into a sill pan or prepared sill with water management it is highly advised to pre-drill and inject sealant in the screw holes prior to fastening the sill bracket.

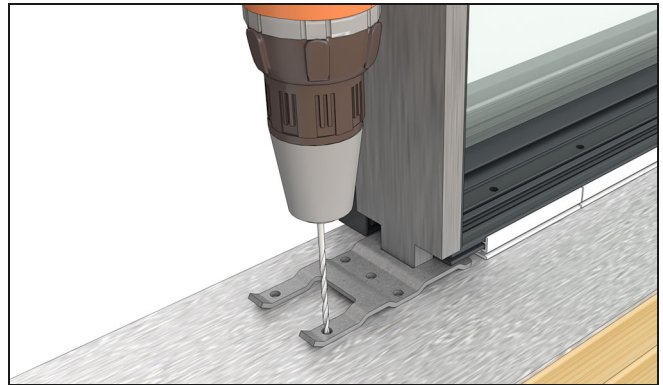

Figure 46

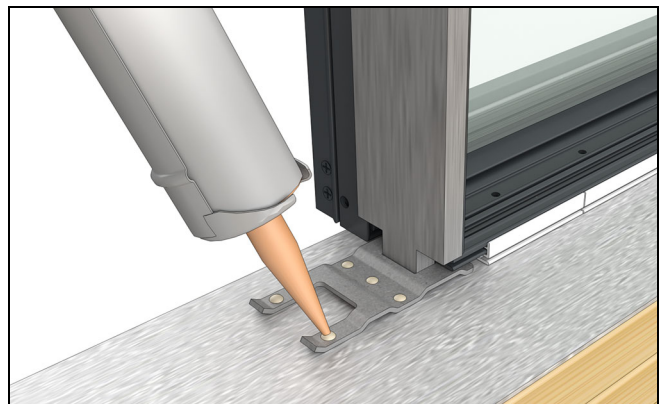

Figure 47

14. Slide the top mull bracket so that it fits over the tab on the mull steel. See Figure 48.

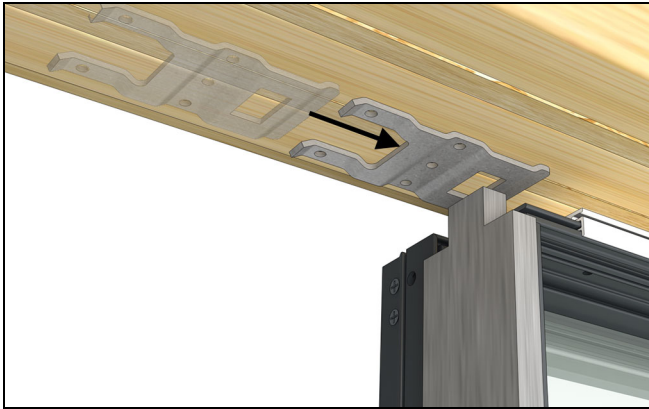

Figure 48

15. Shim the top bracket so that when it is fastened to the RO it will be no more than 1/8" away from the top of the frame/shim block. See Figure 49.

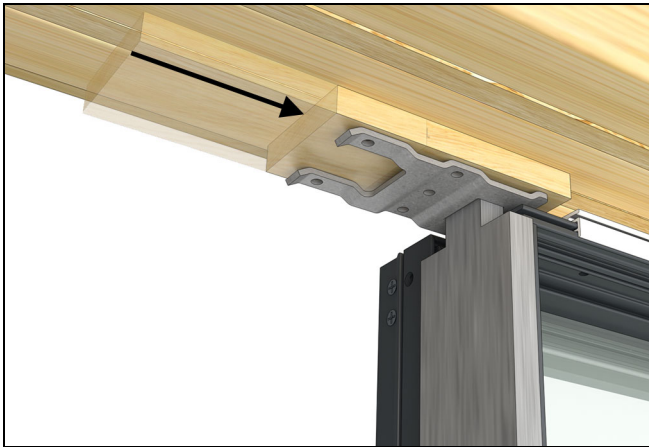

Figure 49

16. Fasten the top bracket to the RO with the 3" screws provided. See Figure 50.

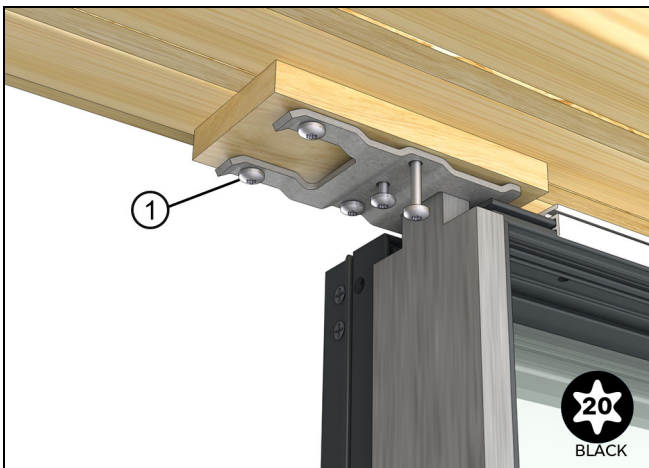

Figure 50

1	#10 x 3" Installation screw
---	-----------------------------

NOTE: You might have your own preference for screws depending on your steel of choice. Adjust the bit size accordingly.

17. Using the pre-drilled installation holes in the frame as a guide, drill through the steel with a #23 bit and driver. Fasten the steel to the frame with the included #8-32 x 1/2" trilobular screws See Figure 51.

NOTE: You may need to first drill with a 1/8" bit.

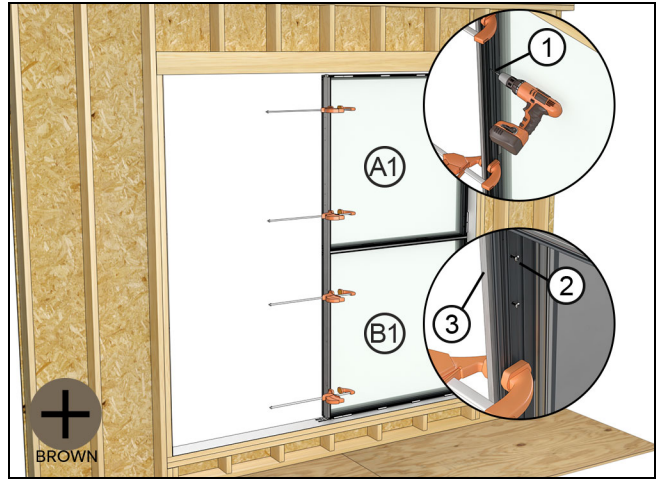

Figure 51

1	#23 drill bit
2	#8 x 1/2" trilobular screw
3	Flat steel

18. Apply sealant to the exterior bottom portion of the first assembly (along the B1 frame). Run the sealant just past the mull. See Figure 52.

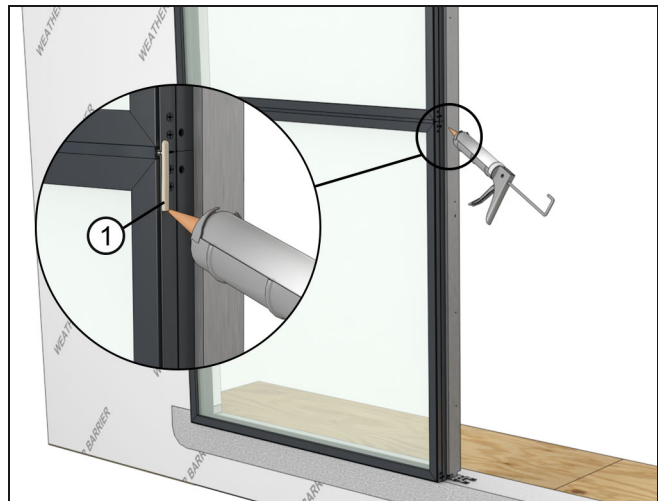

Figure 52

1	Sealant
---	---------

 **Hint**

In some cases, it may be preferred to assemble a standard mull first, outside the rough opening, and then install that as one assembly before proceeding with the structural steel mull. The following illustrations show installing the assembly and mulling one unit at a time in the rough opening.

19. Set the bottom portion (B2) of the next assembly in place. If this is the last subassembly in the mull, you can hold this in place temporarily with shims. Otherwise you will need another person or the proper equipment to hold the unit in place before you proceed. [See Figure 53.](#)



Figure 53 Install B2 (exterior view)

20. Clamp this unit to the previous assembly, making sure that the interiors are flush and aligned along the entire jamb. [See Figure 54.](#)

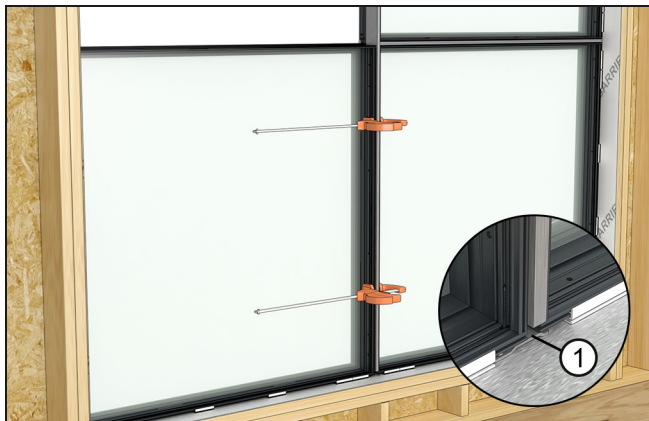

Figure 54

1	Frames are even and flush along the entire mull
---	---

21. Making sure the B2 frame is aligned along the correct exterior plane, fasten the sill through pre-drilled holes in both frames. [See Figure 55.](#)

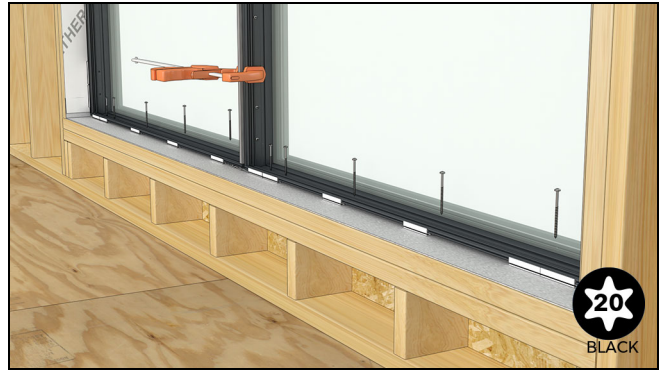

Figure 55

22. Pin the top of the jamb with an installation screw. [See Figure 56.](#)



Figure 56

1	Installation screw
---	--------------------

23. If not already attached from the factory, fasten the horizontal mull pin for the standard mull atop the B2 unit following procedures outlined previously. See [Figure 57](#).

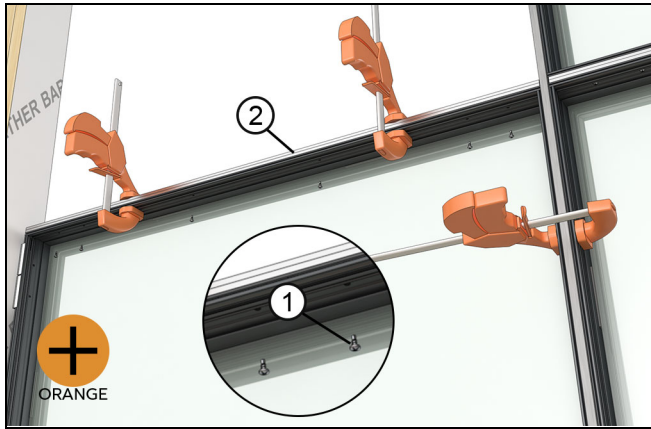

Figure 57

1	#8 x 1/2" screws
2	Mull pin

24. Apply sealant to the exterior along the top of the bottom unit (B2) and the remaining way (or past the next mull) on the previous assembly. See [Figure 58](#).



Figure 58 Exterior view

NOTE: If you are mulling an assembly wider or different than a 2w2h as shown here, continue to mull using the procedures found in [step 11 on page 13](#) through [step 18 on page 15](#).

25. Carefully position the next unit (A2) in place. See [Figure 59](#).

NOTE: Having the right equipment to assist you in this step is crucial. There is minimal clearance to maneuver the unit head jamb past the head jamb mull bracket. Avoid disturbing the sealant on the first assembly if at all possible.



Figure 59 Install the A2 (exterior view)

26. Clamp the two assemblies together at the top and assemble the standard mull and fasten with 1/2" screws. See [Figure 60](#).



Figure 60

27. Making sure the second frame is aligned along the correct exterior plane, fasten the sill through pre-drilled holes in both frames. See [Figure 61](#).

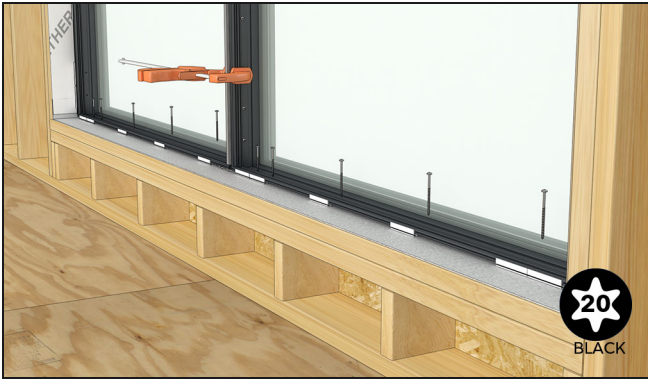

Figure 61

28. Pin the jamb with an installation screw. See Figure 62

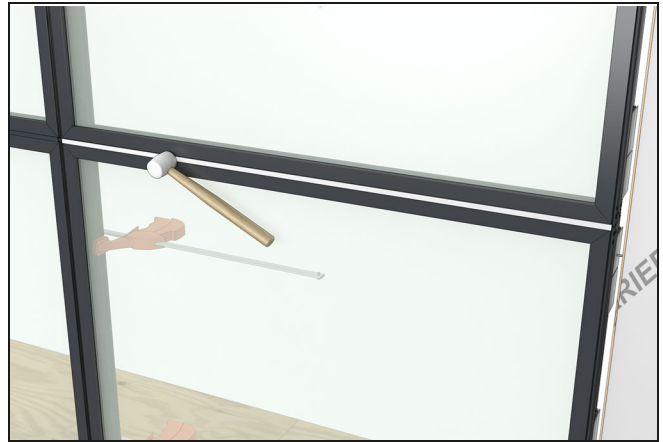

Figure 63 Horizontal mull cap



Figure 62

1	Installation screw
---	--------------------

29. Apply the exterior mull caps and seat with a rubber mallet. Clean any excessive sealant squeeze out. See Figure 63 and Figure 64.



Figure 64 Vertical mull cap

30. Using a drill with a stop collar use the installation holes as a guide and bore into the steel with a #23 drill bit. Note the depth of the stop collar on [Figure 65](#) for different products.

IMPORTANT

Do not bore through the steel and into the opposite framing.

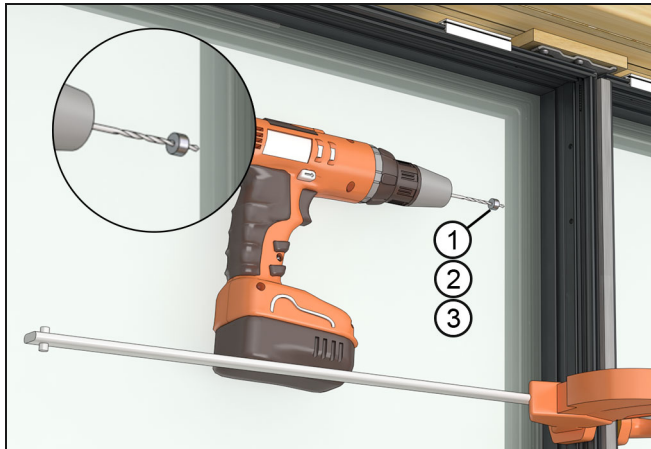

Figure 65 Use stop collar to determine depth. See table below

1	DG: #23 drill bit with stop collar set to 5/8" depth
2	Casement: #23 drill bit with stop collar set to 1 1/4" depth
3	Doors: #23 drill bit with stop collar set to 1" depth

31. Fasten the A2 and B2 to the mull steel using the #8 x 1/2" trilobular screws included. [See Figure 66](#).

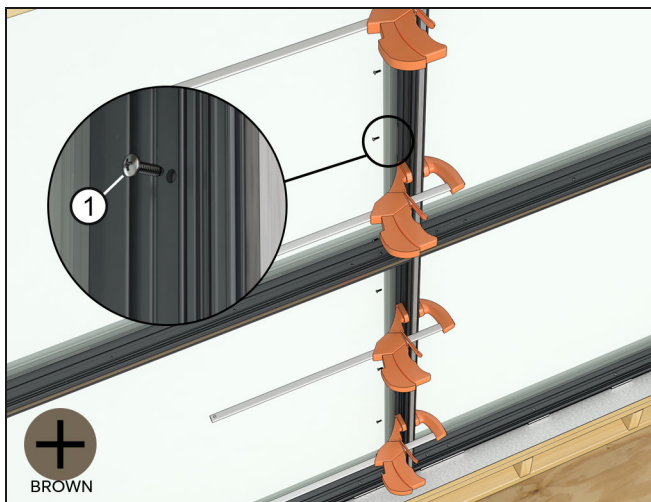

Figure 66

1	#8 x 1/2" Trilobular screws
---	-----------------------------

32. Complete shimming and fastening around the entire perimeter using the pre-drilled installation holes. [See Figure 67](#), [Figure 68](#), and [Figure 69](#).



Figure 67



Figure 68



Figure 69

Window Tube Steel Mulling

Tools and Supplies Needed

- 2" x 4" x 3/16" wall (51 x 106 x 4) **primed** tube steel (spec listed below)
- 1/8" (3) drill bit for drilling into steel tube
- #23 drill bit (.154 inches or 3.911mm) for drilling into steel tube
- Power drill/driver
- Phillips head bit
- Level
- Clamps
- Rubber mallet
- Screen spline roller
- Tape Measure

Steel Specification: ASTM A500B Steel or better.

IMPORTANT

If you are mulling a polygon unit with a sloped head jamb or sill, refer to [Special Instructions for Non-Rectangular Polygons on page 43](#) for more details on using the correct mull brackets.

Parts Included

- Mull Filler (V3037) and Mull Filler Blocks
- #8-32 x 1/2" trilobular screws (frame to steel)
- #10-12 3" T20 Torx pan head 2/3 thread screws (through brackets into RO framing)
- #8-32 x 1 1/4" trilobular screws (frame to steel for Casement only)
- Mull covers
- Mull end brackets
- Mull end foam blocks
- Frame kerf weatherstrip
- CSL 343 Sealant or equivalent

Fabricate the Tube Steel

1. Calculate the length of tube steel for the mull by taking the outside measurement of the frame and subtract 1/8" (3). Cut the steel to this dimension. See [Figure 70](#).

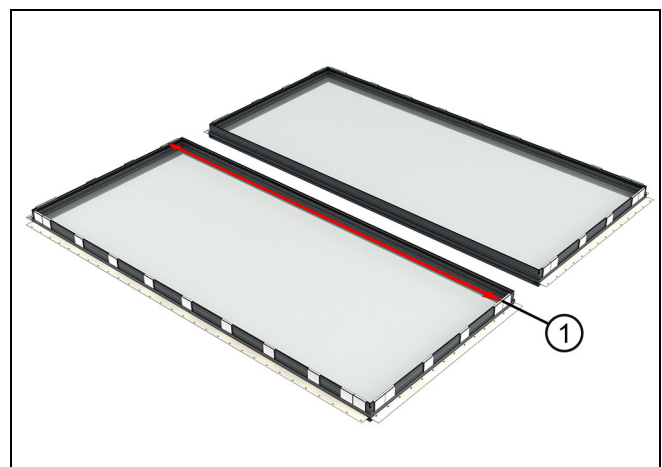

Figure 70

1	Measure full length of mull and subtract 1/8"
---	---

Tube Steel-Ribbon Mulls Assembly and Installation

Using a smartphone or similar device, scan the QR code or go to the link below to play a video of this procedure.



<https://www3.marvin.com/download?vid=133>

This section will demonstrate mulling a two wide unit in the rough opening with a **vertical** mull. The procedure is similar for a horizontal mull. Repeat this process until your assembly is complete. See the [Tube Steel-Multiple Wide and Multiple High Assemblies on page 30](#) if your unit has both vertical and horizontal mulls. Refer to the installation instructions sent in the job box for fastening details.

IMPORTANT

For multiple high and multiple wide assemblies with mixed mull types (standard and structural) make sure to mull the standard sub-assemblies first (refer to [Tube Steel-Multiple Wide and Multiple High Assemblies on page 30](#)).

1. Start with a flat and level opening.
2. Establish an exterior plane along the sill. Use a laser level or snap-line. This will be helpful for larger multiple wide assemblies. See [Figure 71](#).

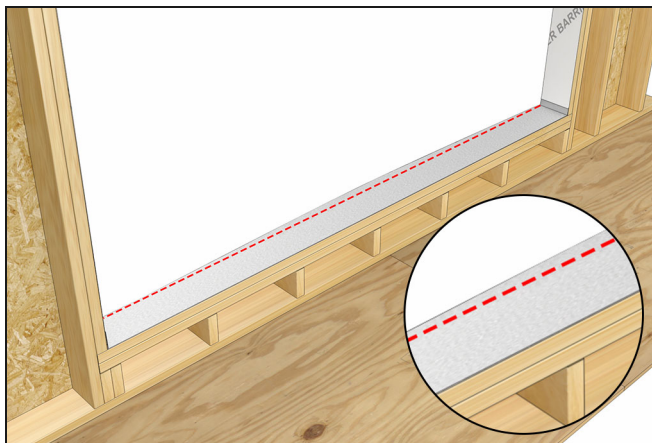

Figure 71

3. Remove any shim blocks along the mulls (if not already done from the factory). Also remove shim blocks from the top and bottom corners adjacent to the mull on units that will **not** have the steel attached to it first. See [Figure 72](#) and [Figure 73](#).

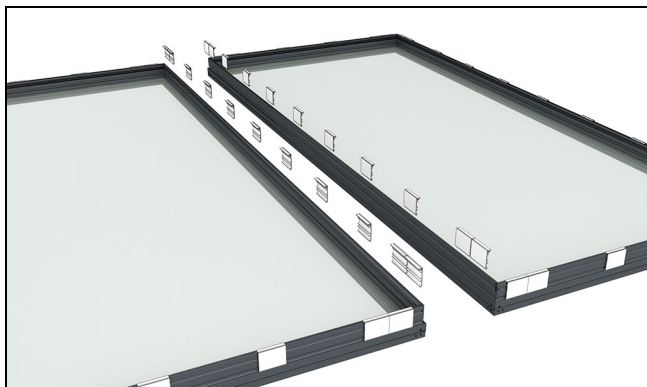

Figure 72

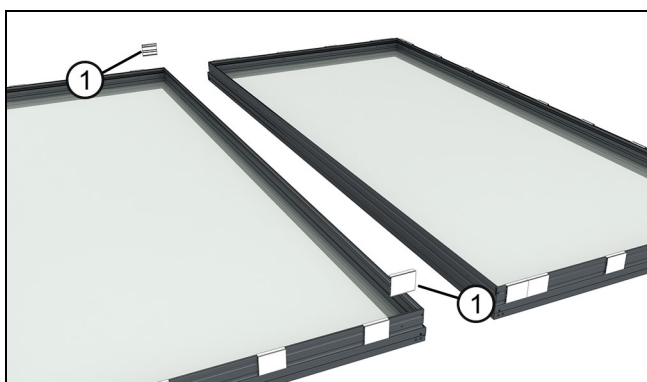

Figure 73

1	Shim blocks
---	-------------

IMPORTANT

Removing the shim blocks from the top and bottom corners will eliminate interference with the mull bracket later.

4. Temporarily attach mull filler blocks about 6" from frame ends. The blocks will barb into the nail fin kerf as shown in [Figure 74](#).

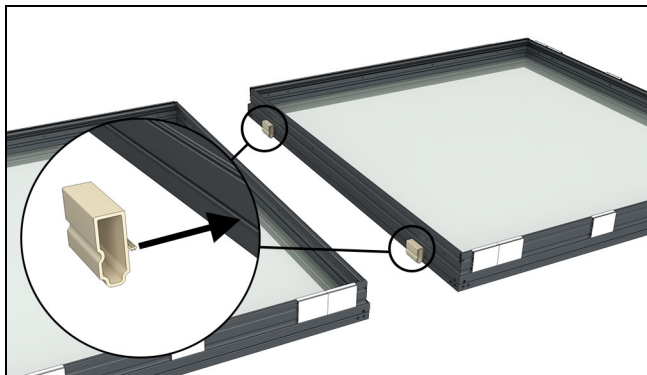

Figure 74

5. Position the first unit in the opening. Shim and plumb the first jamb on the desired vertical plane. See [Figure 75](#) and [Figure 76](#).



Figure 75



Figure 76

1	#10 x 3" Installation screw
---	-----------------------------

6. Temporarily position the mull bracket on the sill. Shim the bracket to the correct height if the unit does not sit flat on the sill plate. The bracket should sit flush with the bottom of the frame/shim block.

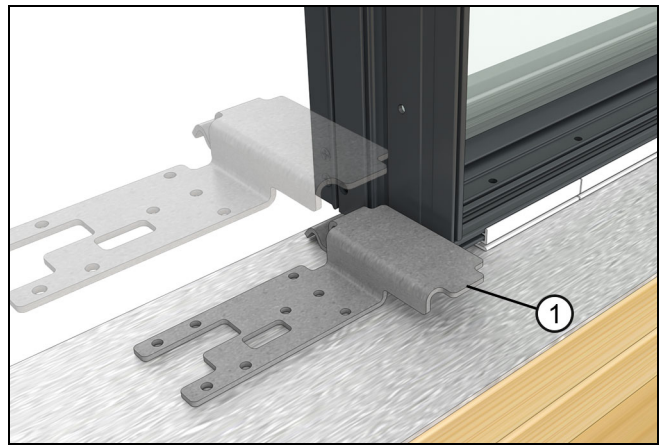

Figure 77

1	Tube steel mull bracket
---	-------------------------

7. Fit the bottom of the tube steel over the raised end of the sill bracket. See [Figure 78](#).

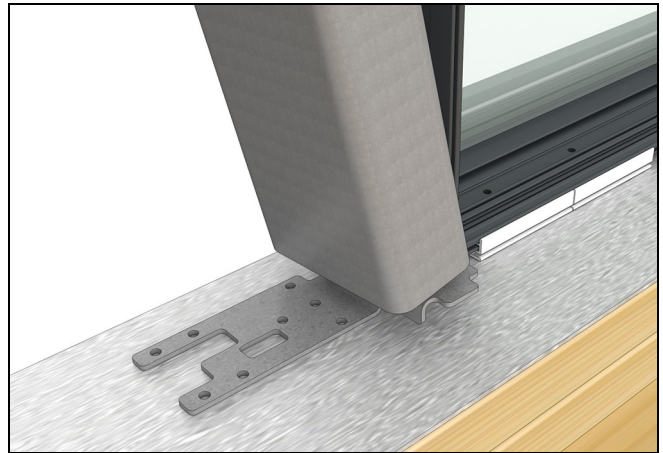

Figure 78

8. Insert the top bracket into the top end of the tube steel. Position the steel tight against the mull filler blocks, then clamp the steel to the frame. See [Figure 79](#), [Figure 80](#), and [Figure 81](#).



Figure 79



Figure 80

1	Mull filler block
---	-------------------

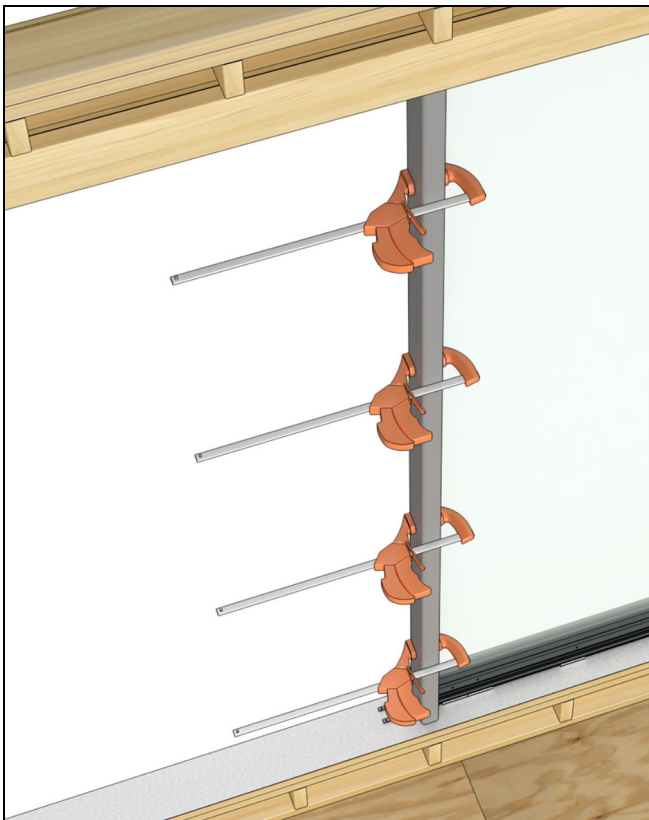

Figure 81

9. Adjust the bracket so it is square in the opening and positioned about 1/4" from the exterior step in the frame. Then fasten it to the sill. Use seven #10-12 3" T20 Torx pan head 2/3 thread screws or similar depending on the sill material. See Figure 82, Figure 83, Figure 84, Figure 85, and Figure 86.

NOTE: If you are drilling into a sill pan or prepared sill with water management it is highly advised to pre-drill and inject sealant in the screw holes prior to fastening the sill bracket.

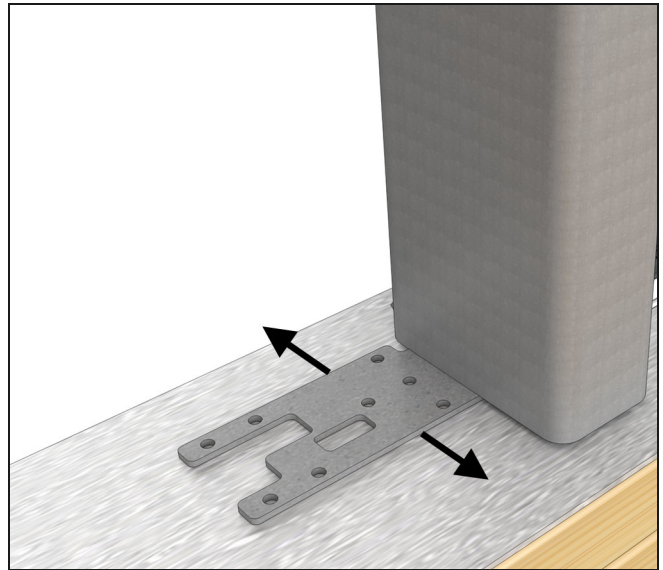

Figure 82

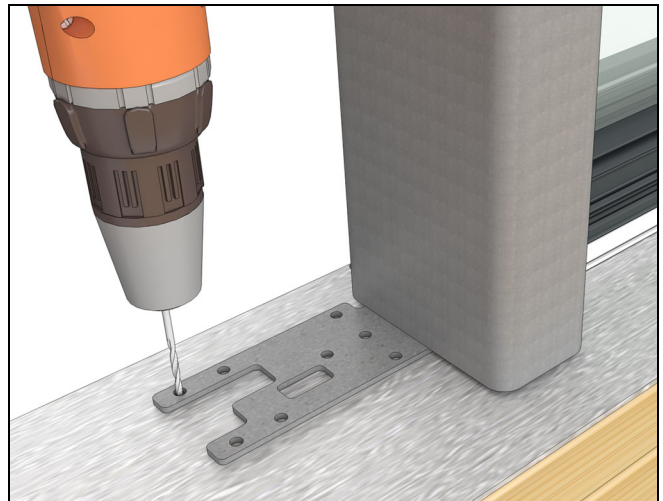

Figure 83

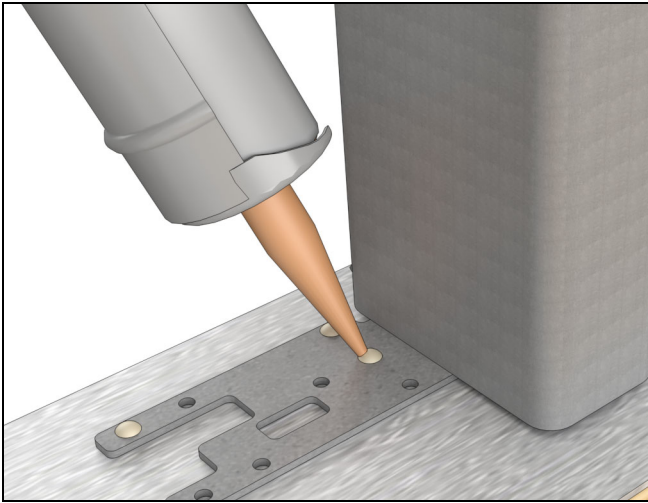

Figure 84

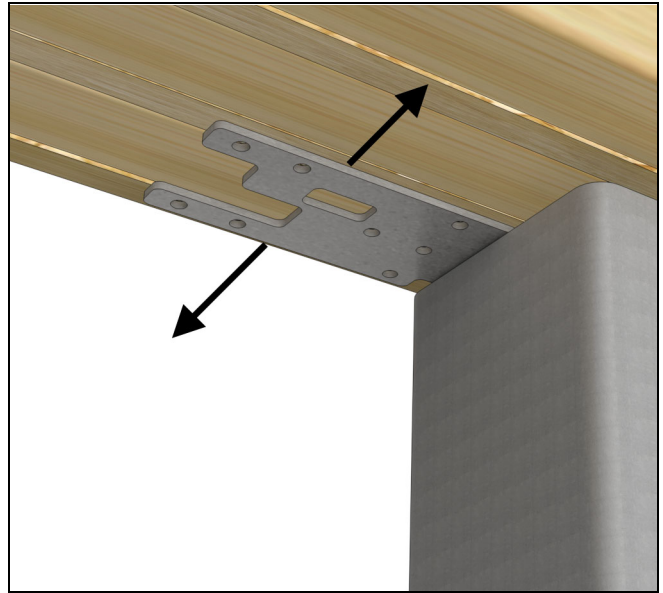

Figure 87

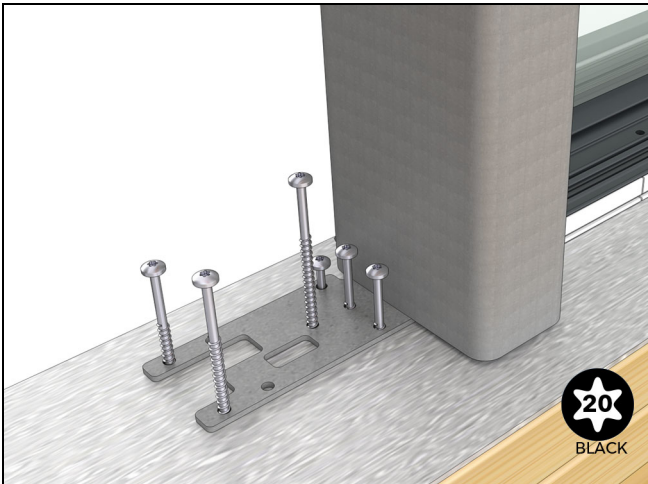

Figure 85

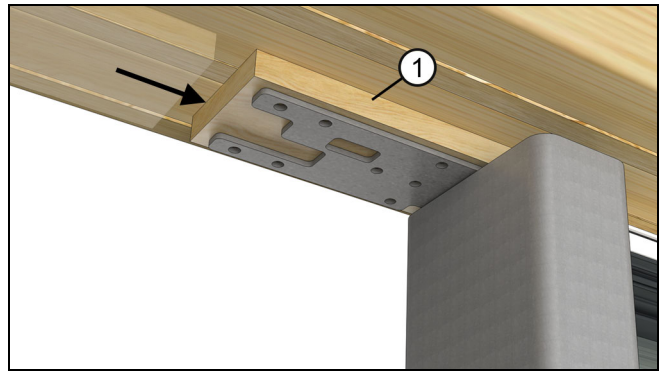

Figure 88

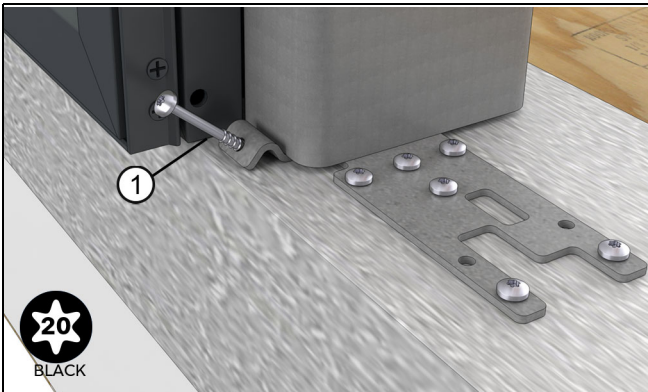

Figure 86



Figure 89

1	Additional installation screw at the exterior
---	---

10. Adjust the top mull bracket and block/shim the bracket firmly against the RO and to seat the bracket in the hollow of the tube steel. Fasten the bracket with the supplied 3" screws. See [Figure 87](#), [Figure 88](#), and [Figure 89](#).

NOTE: You might have your own preference for screws depending on your steel of choice. Adjust the bit size in the [next step](#).

11. Using the pre-drilled installation holes in the frame as a guide, drill through the steel with a #23 bit and driver. See Figure 90.

NOTE: You may need to first drill with a 1/8" bit.



Figure 90

12. Fasten the steel to the frame with the included #8-32 x 1/2" trilobular screws. See Figure 91.



Figure 91

1	#8-32 x 1/2" Trilobular screws
---	--------------------------------

13. Remove the mull filler blocks. See Figure 92.



Figure 92

14. Attach the mull filler to the frame by inserting the barbed leg into the accessory kerf on both sides of the mull. Center the filler on the frame about 3/8" (10) from each end. See Figure 93.

NOTE: The mull filler should be cut to the correct size from the factory. If not, take the outside measurement of the frame and subtract 3/4" (19) and cut the filler to that size.

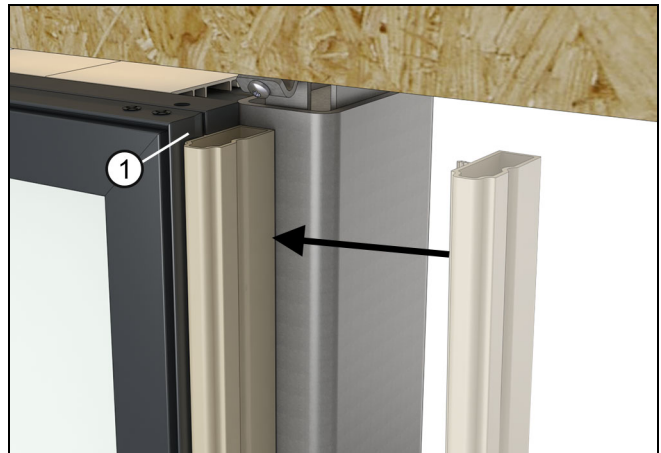

Figure 93 Attach full length mull filler

1	Space filler 3/8" from each end
---	---------------------------------

15. If you had to splice the mull filler, apply a bead of sealant around the top of the filler at the splice joint.

16. Set the second unit in place in the opening. Align the frames and clamp. See Figure 94.

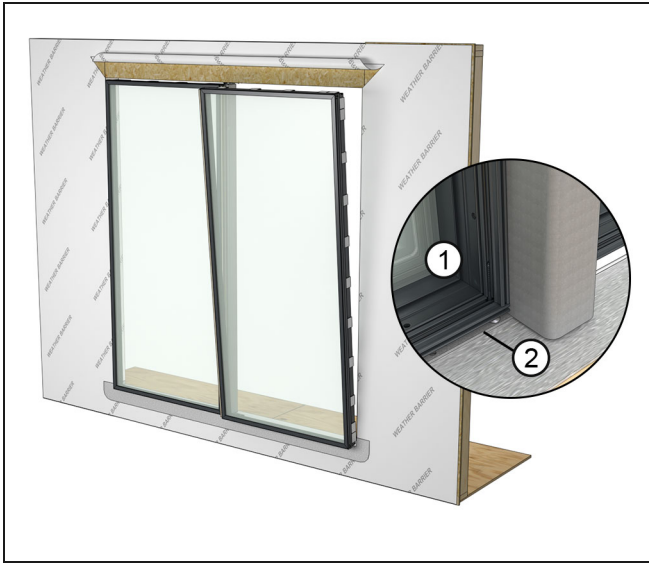

Figure 94

1	A2 unit flush set tight against steel--corner shim blocks removed
2	Sill mull bracket

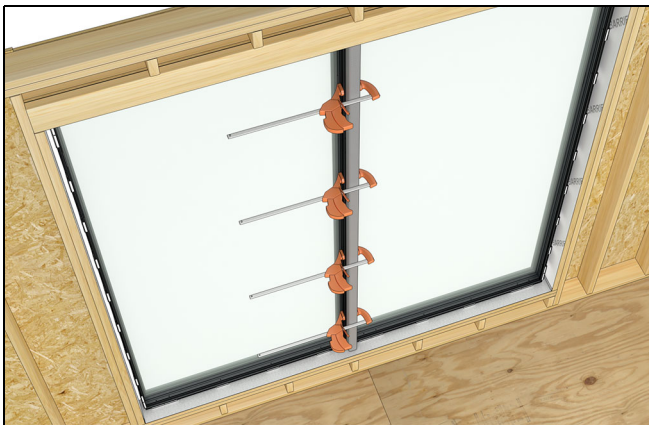

Figure 95

17. Use the installation holes as a guide and bore into the steel with a #23 drill bit. See Figure 96.



Figure 96

1	#23 drill bit
---	---------------

18. Fasten the second frame to the tube steel using the #8 x 1/2" trilobular screws provided. See Figure 97.



Figure 97

1	#8 x 1/2" trilobular screws
---	-----------------------------

19. Making sure the second frame is aligned along the correct exterior plane, fasten the sill through pre-drilled holes in both frames. See Figure 98.

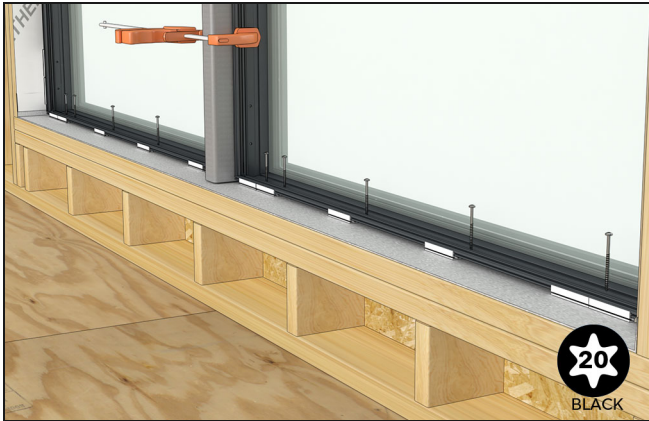

Figure 98

20. Square and plumb the second frame in the opening and then shim and fasten the jamb. See Figure 99.



Figure 99

21. Complete fastening around the entire perimeter using the pre-drilled installation holes. See Figure 100.

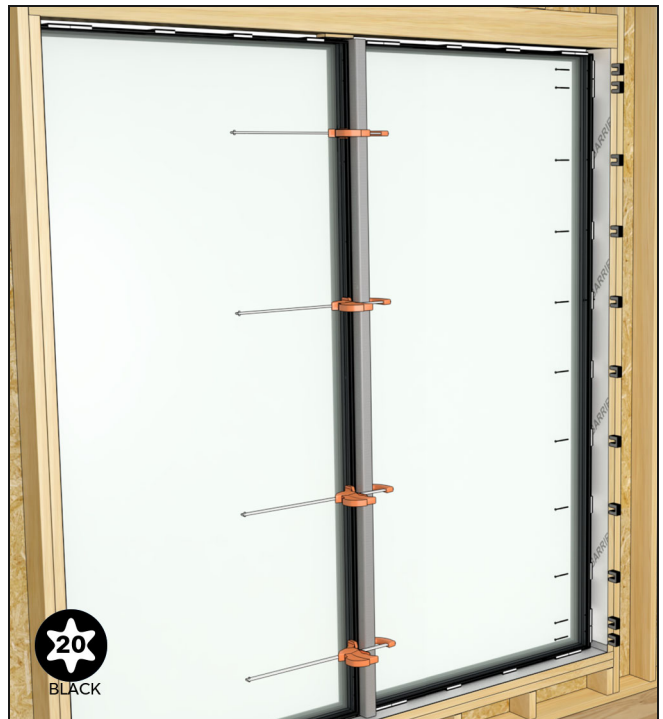

Figure 100

22. Using a screen spline roller or similar tool, apply frame kerf weather strip in the frame kerf along the mull. See Figure 101.

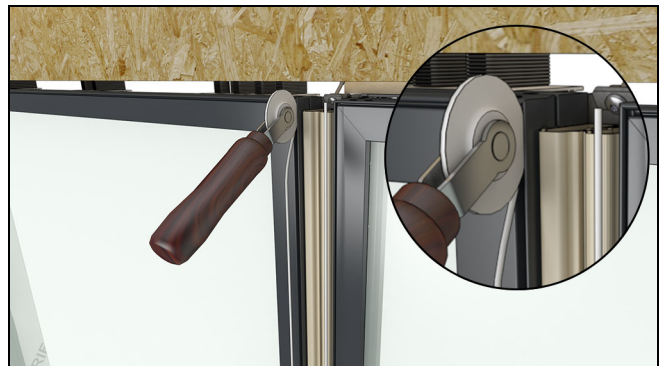

Figure 101

23. Apply three beads of sealant over the mull fillers— one on each side (between the fillers and frame) and one in the middle. See [Figure 102](#).

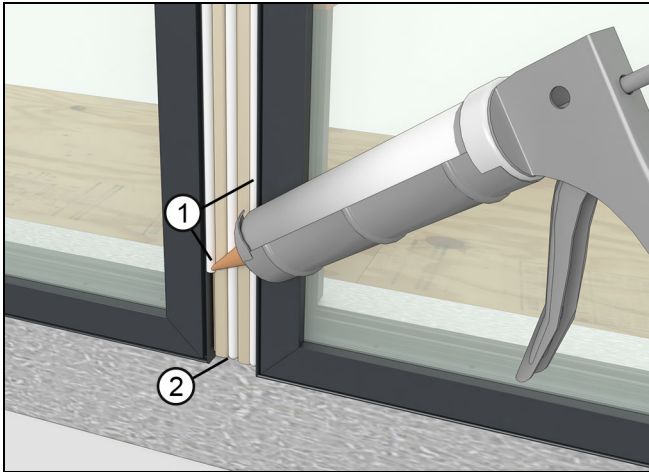

Figure 102

1	Sealant between filler and frame
2	Sealant between fillers

24. Apply sealant on the ends of the mull filler and over the ends of the tube steel as shown in [Figure 103](#) and [Figure 104](#).



Figure 103



Figure 104

25. Seat foam blocks in the sealant. See [Figure 105](#) and [Figure 106](#).

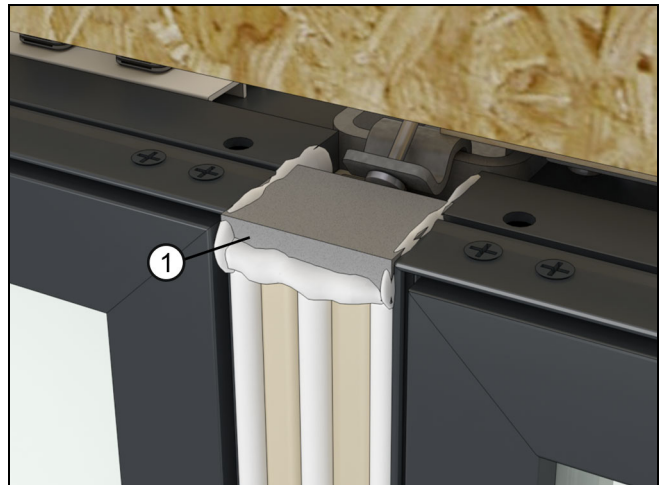

Figure 105

1	Mull foam block
---	-----------------



Figure 106

26. Install the exterior mull cover. Seat in place with a rubber mallet. See [Figure 107](#).



Figure 107



Hint

Clean any excessive sealant off the frame at this time.

Tube Steel-Multiple Wide and Multiple High Assemblies

Using a smartphone or similar device, scan the QR code or go to the link below to play a video of this procedure.



<https://www3.marvin.com/download?vid=134>

The following steps will show a 2 wide/2 high configuration but would be similar for other multiple high multiple wide configurations. As a general rule mull any standard mulls first following the steps in the [Mulling Instructions](#), then proceed with the structural mull.

Frames are typically prepped from the factory for multiple wide/multiple high assemblies. In the event that the exterior frame kerf is not prepared from the factory, refer to the following steps to remove material from the corners of individual units where there is a cross section of mulls (i.e. the middle of a 2W2H configuration).

ATTENTION

If you have determined your frames are already prepped properly from the factory you can skip to [step 5 on page 31](#).

1. Place the individual units on a flat sturdy surface exterior side up.
2. Place the individual units on a flat sturdy surface exterior side up. Use a hacksaw, rotary tool, or oscillating tool, to remove material from the corners of individual units to allow the mull cap to pass. Remove about 1/8" (3) of material from the accessory kerf leg that runs perpendicular to the direction of the mull. [See Figure 108](#).

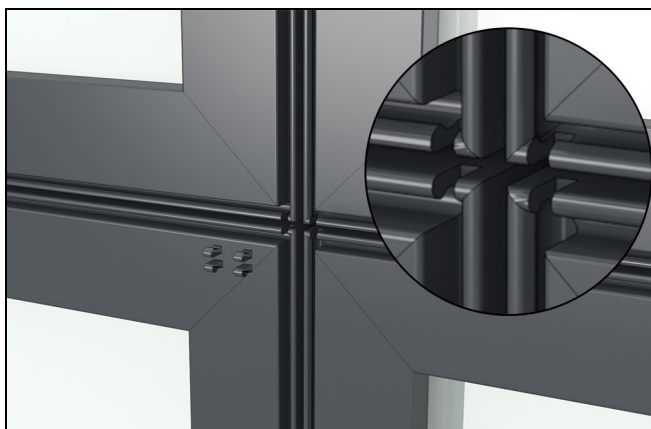

Figure 108

3. Remove any shim blocks along the mulls. Also remove shim blocks from the top and bottom corners

adjacent to the mull on units that do not have the steel attached to it first. [See Figure 109](#) and [Figure 110](#).

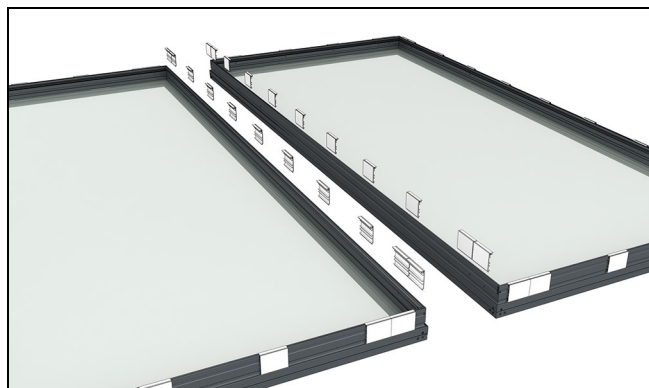

Figure 109

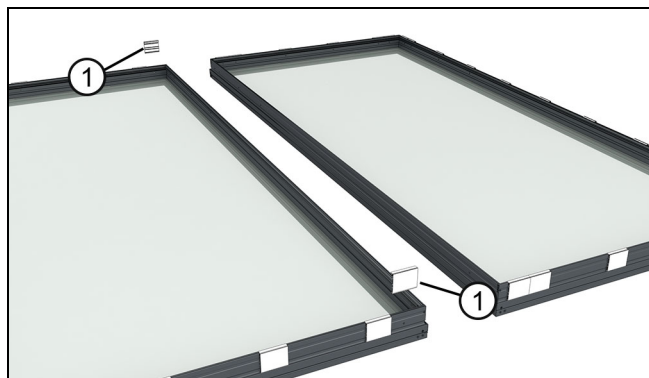

Figure 110 Remove end blocks that will interfere with the mull bracket.

1	Shim blocks
---	-------------

IMPORTANT

Removing the shim blocks from the top and bottom corners will eliminate interference with the mull bracket later.

4. On the mull side of the assembly, attach mull filler blocks about 6" from each end of each frame. The blocks will barb into the nail fin kerf as shown in [Figure 111](#).

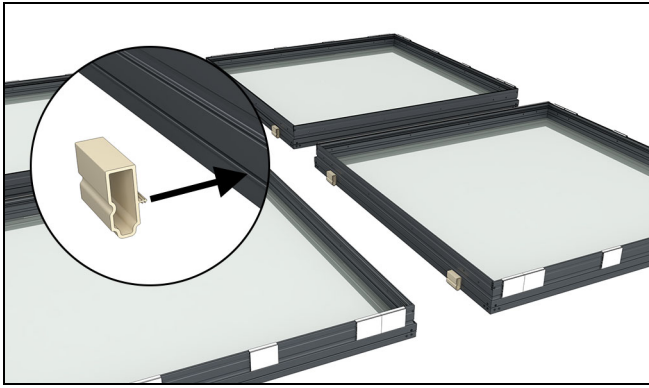

Figure 111

5. Establish an exterior plane along the sill. Use a laser level or snap line. This will be helpful for larger multiple wide assemblies. See Figure 112

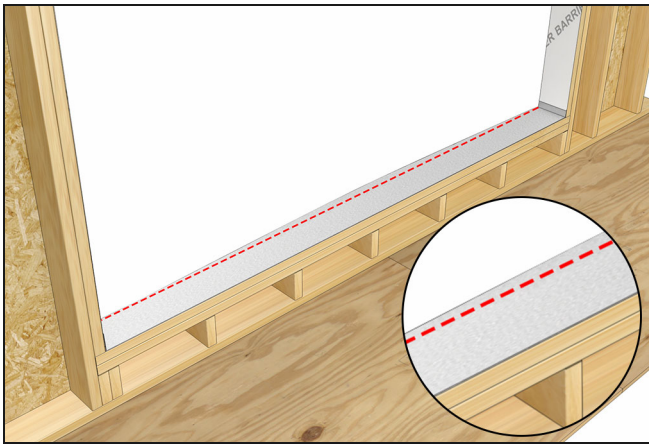

Figure 112



Hint

In some cases, it may be preferred to assemble a standard mull first, outside the rough opening, and then install that as one assembly before proceeding with the structural steel mull. The following illustrations show installing the assembly and mulling one unit at a time in the rough opening.

6. Set the first assembly (B1) in place in the opening. Square, plumb, and pin the jamb. See Figure 113.

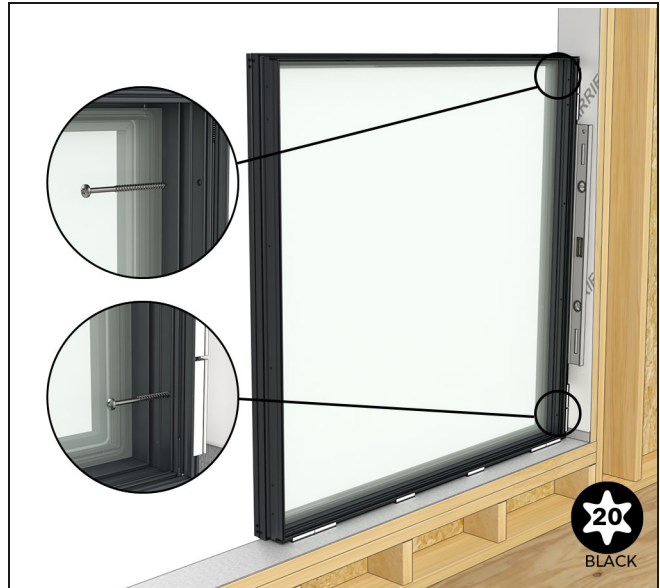

Figure 113

7. Mull the second unit (A1) to the first (B1). For standard tight mulls, follow procedures found in the [mull instructions](#). For structural or flat steel mulls, refer to the appropriate procedures within this instruction. See Figure 114

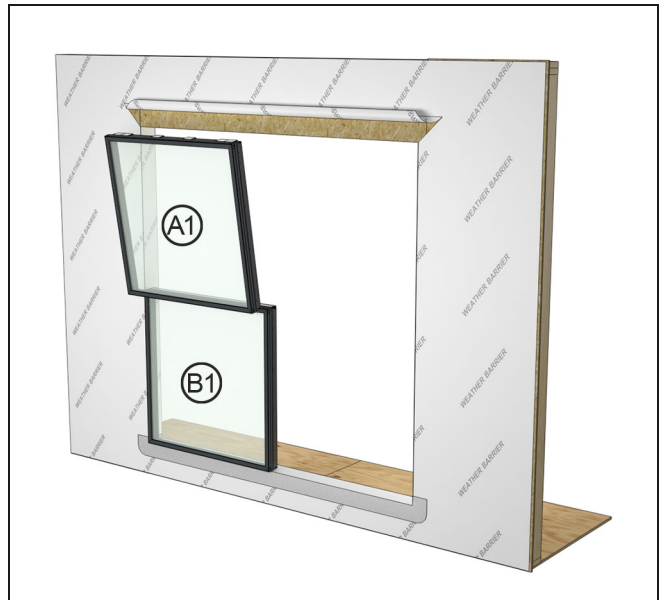

Figure 114

8. Once the B1 and A1 assembly is mullled, square plumb and pin the jamb. See Figure 115.



Figure 115

1	#10 x 3" T20 installation screw
---	---------------------------------

9. Install the exterior horizontal mull clip. See [Figure 116](#)



Figure 116

10. Temporarily position the mull bracket on the sill. Shim to get the bracket to the correct height if the unit does not sit flat on the sill plate. The bracket should sit flush with the bottom of the frame/shim block. See [Figure 117](#).

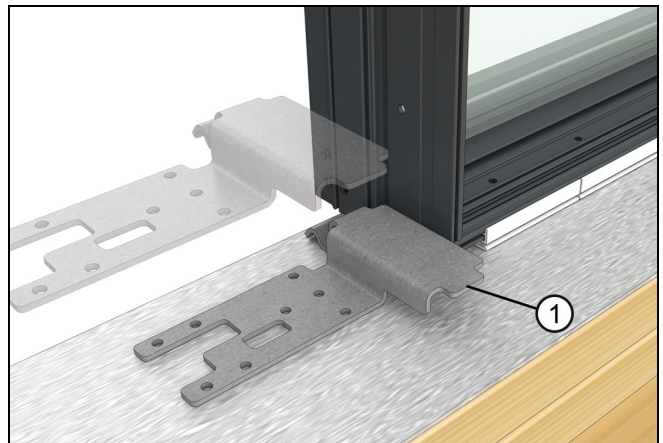

Figure 117

1	Tube steel mull bracket
---	-------------------------

11. Insert the top bracket into the top end of the tube steel. While holding the top bracket in the top of the tube steel, fit the bottom over the raised end of the sill bracket. See [Figure 118](#) and [Figure 119](#).



Figure 118

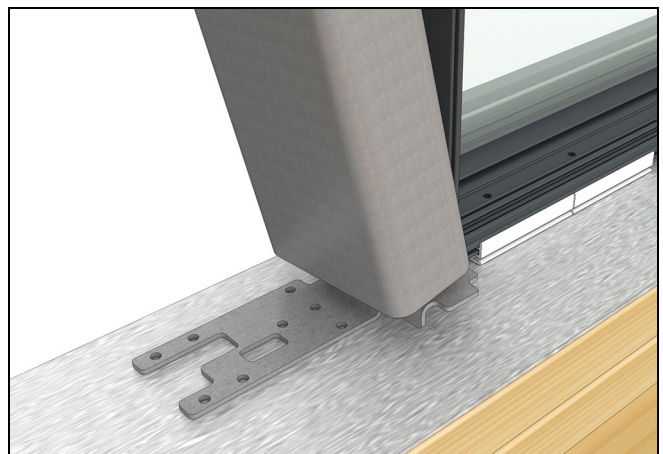

Figure 119

12. Position the steel tight against the mull filler blocks, then clamp the steel to the frame. See Figure 120 and Figure 121.



Figure 120

1	Mull filler block
---	-------------------

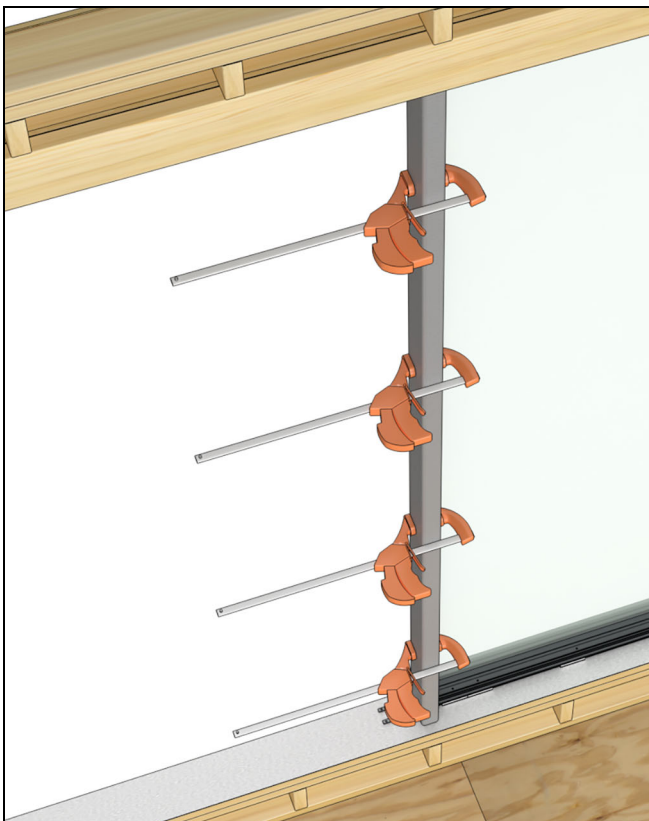

Figure 121

13. Adjust the bracket so it is square in the opening and positioned about 1/4" from the exterior step in the frame, then fasten it to the sill. Use seven #10-12 3" T20 Torx pan head 2/3 thread screws or similar depending on the sill material. See Figure 122, Figure 123, Figure 124, Figure 125, and Figure 126.

NOTE: If you are drilling into a sill pan or prepared sill with water management it is highly advised to pre-drill and inject sealant in the screw holes prior to fastening the sill bracket.

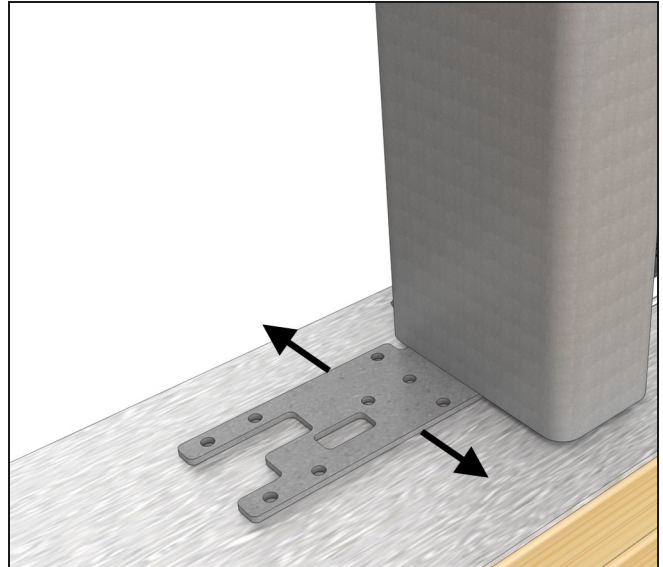

Figure 122

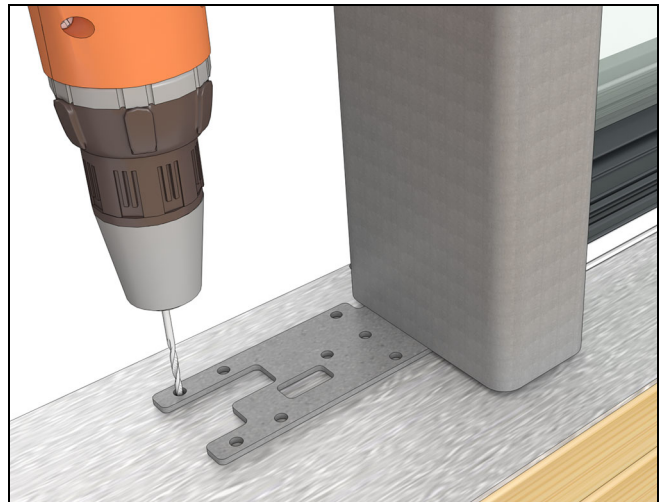

Figure 123

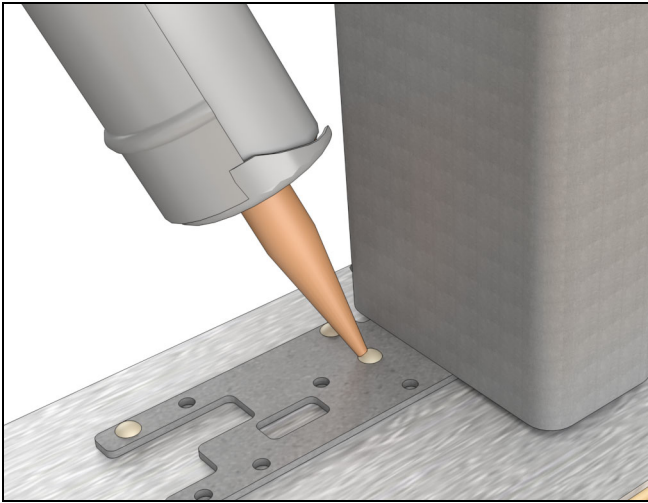

Figure 124

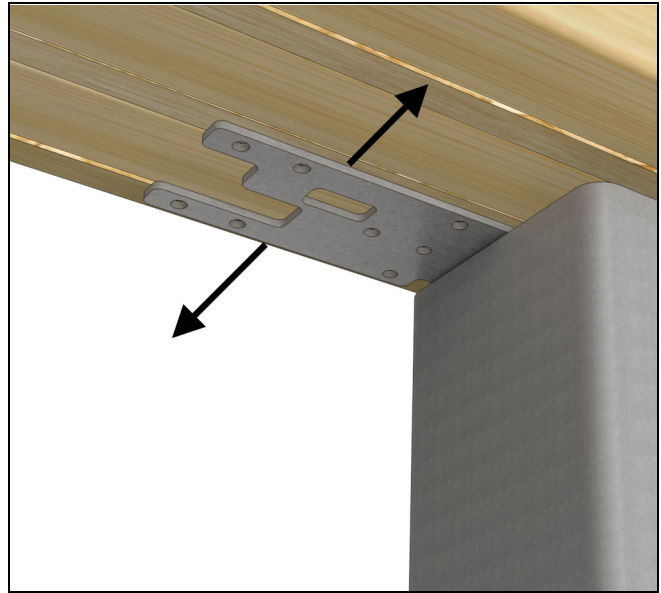

Figure 127

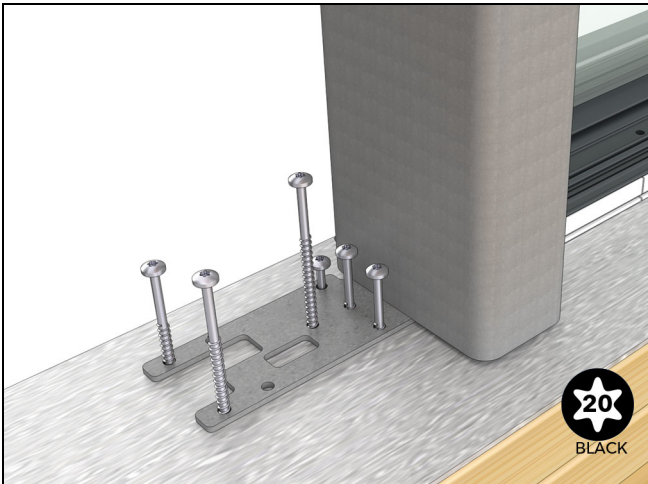

Figure 125

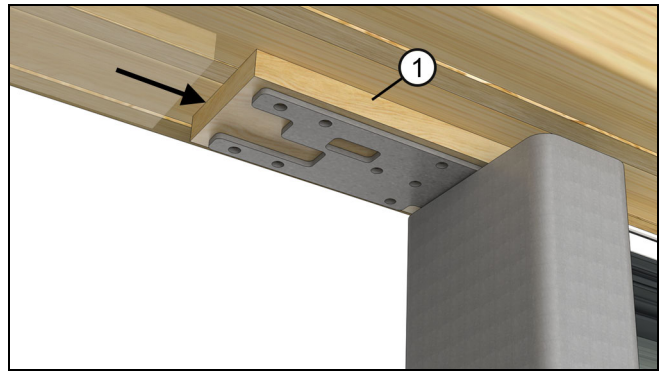

Figure 128

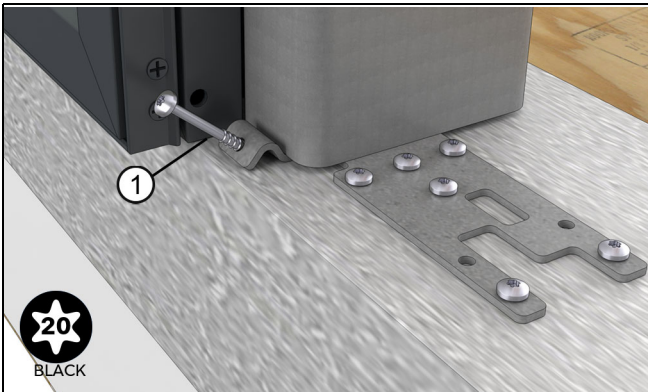

Figure 126



Figure 129

1	Additional installation screw at the exterior
---	---

14. Adjust the top mullion bracket and block/shim the bracket firmly against the RO and to seat the bracket in the hollow of the tube steel. Fasten the bracket with the supplied 3" screws. See Figure 127, Figure 128, and Figure 129.

NOTE: You might have your own preference for screws depending on your steel of choice. Adjust the bit size in the next [step 15 on page 34](#)

15. Using the pre-drilled installation holes in the frame as a guide, drill through the steel with a #23 bit and driver. See Figure 130.

NOTE: You may need to first drill with a 1/8" bit.



Figure 130

16. Fasten the steel to the frame with the included #8-32 x 1/2" trilobular screws. [See Figure 131.](#)



Figure 131

17. Remove the temporary mull filler blocks. [See Figure 132.](#)

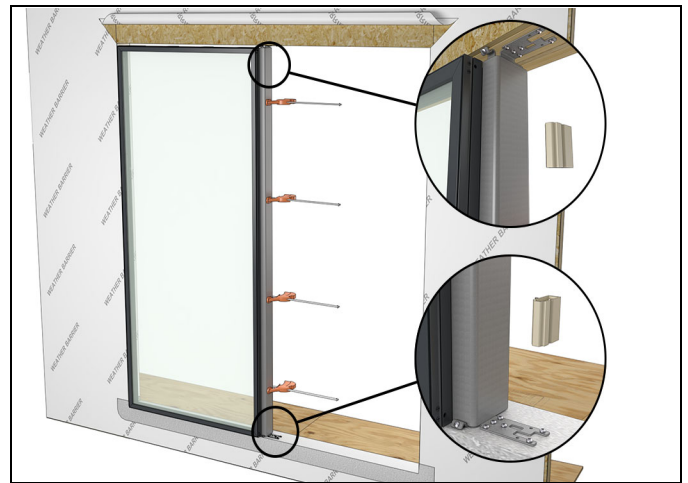

Figure 132

18. Attach the full length mull filler to the frame assembly by inserting the barbed leg into the accessory kerf on both sides of the mull. Center the filler on the frame about 3/8" (10) from each end.

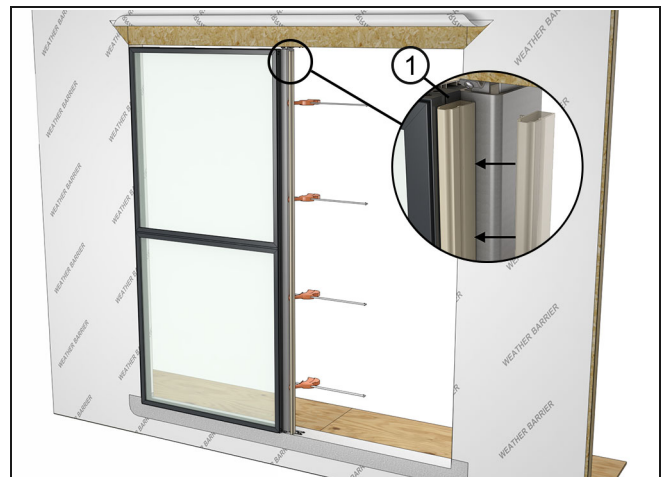

Figure 133

1	Insert mull filler 3/8" from the edge of the frame
---	--

NOTE: If you have assembled the standard mull separately, apply the mull filler to the full length and proceed to [step 30 on page 38](#)

19. Cut the mull filler to length and apply on the B2 unit. The filler should stop about 3/8" from the bottom and flush with the top. [See Figure 134.](#)

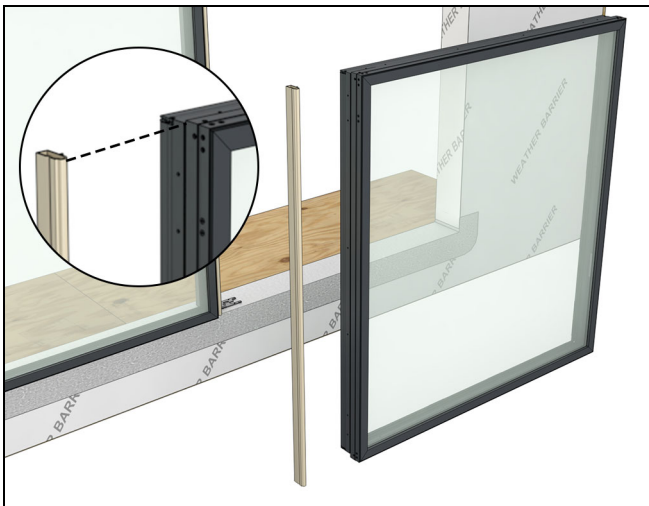

Figure 134

20. Set the B2 unit in place. If this is the last subassembly in the mull, you can hold this in place temporarily with shims. Otherwise you will need another person or the proper equipment to hold the unit in place before you proceed. See Figure 135.



Figure 135

21. Clamp this unit (B2) to the previous assembly, making sure that the interiors are flush and aligned along the entire jamb. See Figure 136.



Figure 136

22. Making sure the B2 frame is aligned along the correct exterior plane, fasten the sill through pre-drilled holes in both frames. See Figure 137.



Figure 137

23. Use the pre-drilled assembly holes as a guide to drill into the mull steel with a #23 drill bit. See Figure 138.

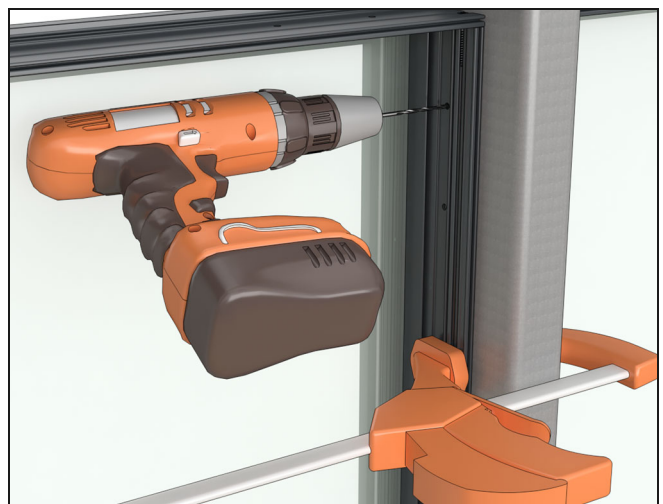

Figure 138

24. Fasten the B2 frame to the tube steel using the #8 x 1/2" trilobular screws. See Figure 139.

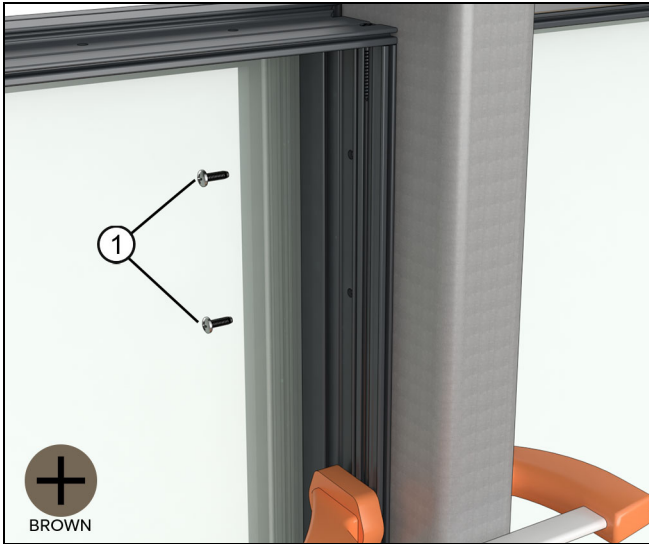

Figure 139

1	#8x 1/2" Trilobular screws
---	----------------------------

25. Shim and pin the top of the B2 jamb to the rough opening. See Figure 140.



Figure 140

26. Apply a bead of sealant on top of the B1 exterior. See Figure 141.

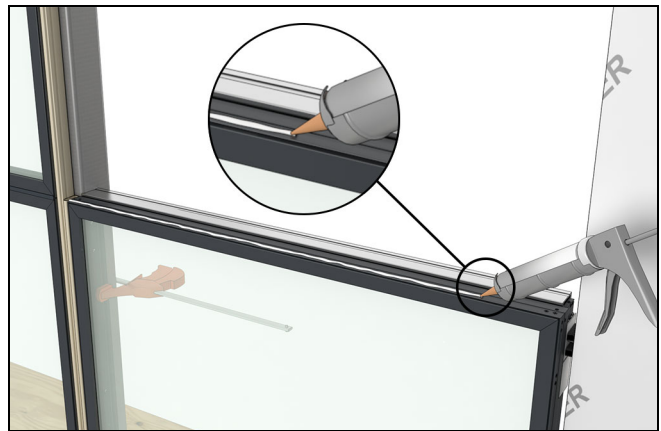

Figure 141

27. Apply a generous bead of sealant around the top edge of the filler block (on the B2 unit). See Figure 142.



Figure 142

28. Attach a mull filler block to the A2 unit flush with the bottom of the frame and about 3/8" from the top. See Figure 143.



Figure 143

29. Carefully position the A2 unit in place and assemble the standard mull. See Figure 144.

NOTE: Having the right equipment to assist you in this step is crucial. There is minimal clearance to maneuver the unit head jamb past the head jamb mull bracket. Avoid disturbing the sealant on the first assembly if at all possible.



Figure 144

30. Clamp the two assemblies together. See Figure 145.



Figure 145

31. Fasten the A2 to B2 unit with a standard mull and the 8 x 7/16" Phillips head screws. See Figure 146.

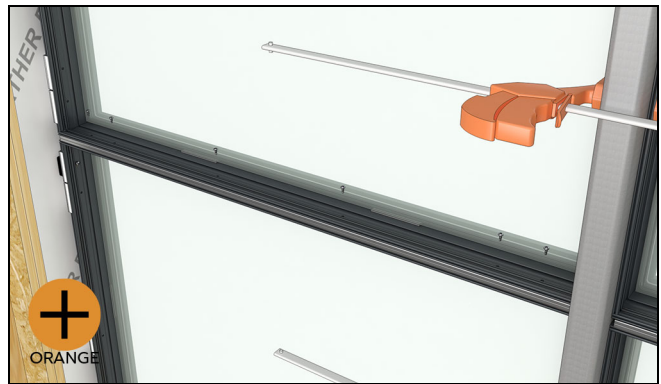

Figure 146

32. Install the exterior horizontal mull clip. Seat with a rubber mallet. See Figure 147.



Figure 147

33. Use the installation holes as a guide and bore into the steel with a #23 drill bit. See Figure 148.



Figure 148

1	#23 drill bit
---	---------------

34. Fasten the A2 unit to the tube steel using the #8 x 1/2" trilobular screws included. See Figure 149 and Figure 150.



Figure 149

1	#8 x 1/2" trilobular screws
---	-----------------------------



Figure 150

35. Complete fastening around the entire perimeter using the pre-drilled installation holes. See [Figure 151](#), [Figure 152](#), and [Figure 153](#).



Figure 151



Figure 152



Figure 153

36. Using a screen spline roller or similar tool, apply frame kerf weather strip in the frame kerf along the mull. See Figure 154.

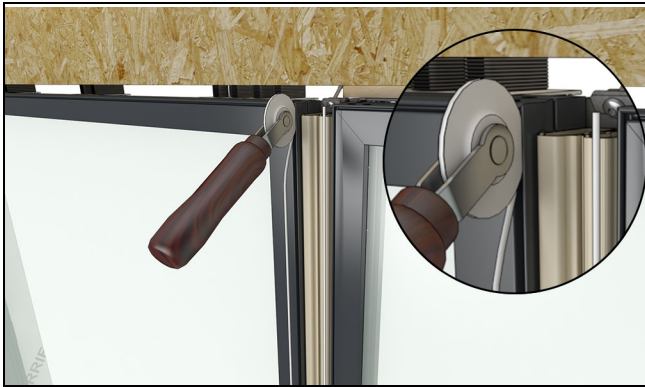

Figure 154

37. Apply three beads of sealant over the mull fillers--one on each side (between the fillers and frame) and one in the middle. See Figure 155

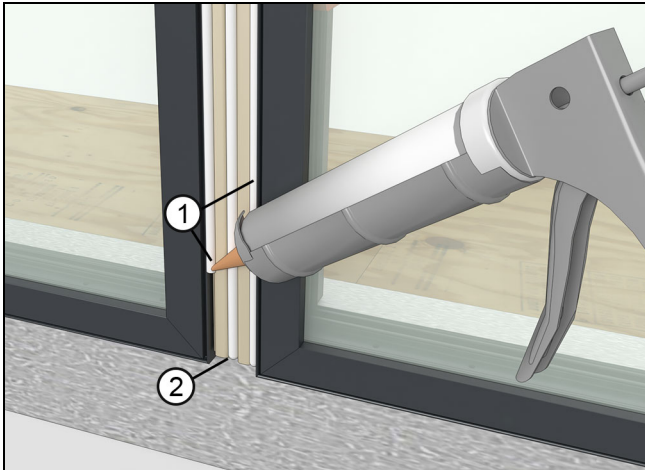

Figure 155

1	Sealant between filler and frame
2	Sealant between fillers

38. Apply sealant on the ends of the mull filler and over the ends of the tube steel as shown in Figure 156 and Figure 157.

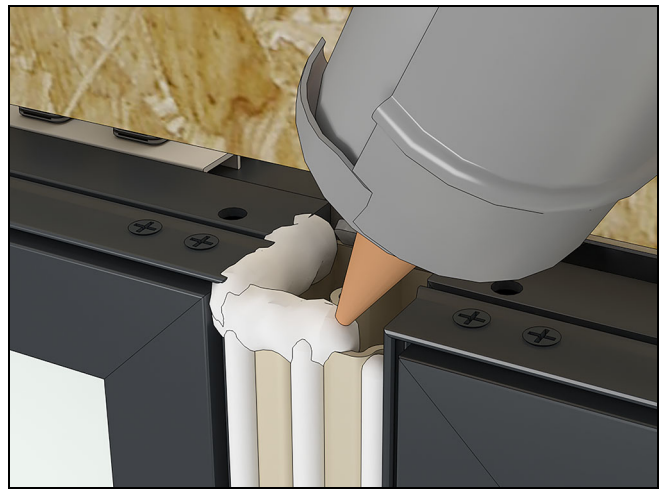

Figure 156



Figure 157

39. Seat foam blocks in the sealant. See Figure 158 and Figure 159.



Figure 158

1	Mull foam block
---	-----------------



Figure 159

40. Install the exterior mull cover. Seat in place with a rubber mallet. See [Figure 160](#)



Figure 160



Hint

Clean any excessive sealant off the frame at this time.

Special Instructions on Casement Units

1. If your assembly includes a casement muller above another assembly, you will need to fasten the hardware base to the mull using the 1 1/4" trilobular screws. Pre-drill using a #23 drill bit.

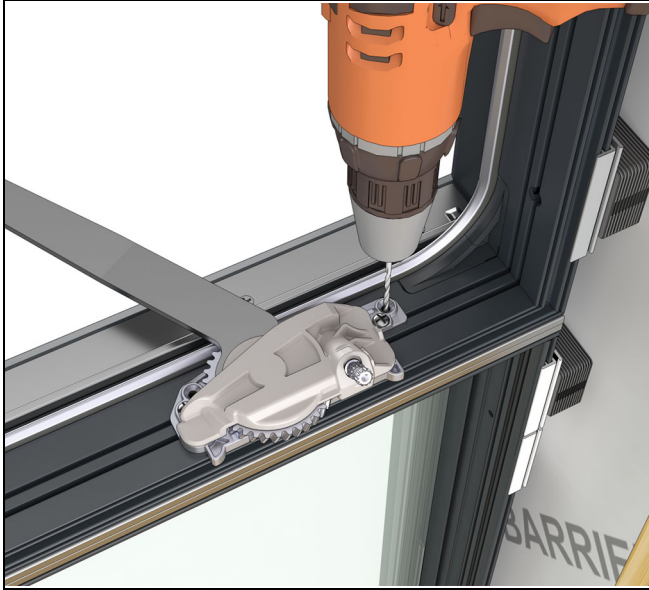

Figure 161

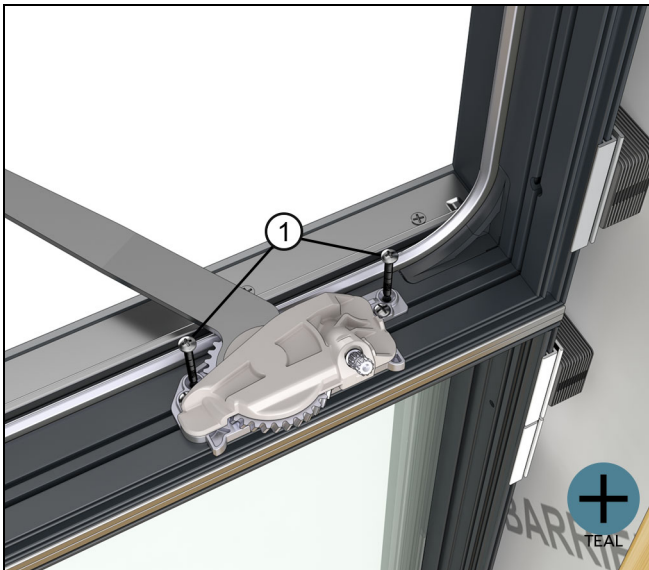

Figure 162

1	#8 x 1 1/4" Trilobular screw
---	------------------------------



1.A. If the motorized frame bracket is next to a mull pin, and the mull pin is not attached to the window, you will need to attach the mull pin and then fasten through the frame bracket. Pre-drill with a #29 or 9/64" drill bit

and fasten with the 1 1/4" trilobular screws found in the bag marked with the teal dot. Replace 2 screws on all frame brackets except Awnings less than 20" tall, which will have 1 screw replaced. See Figure 163 and Figure 164.



Figure 163

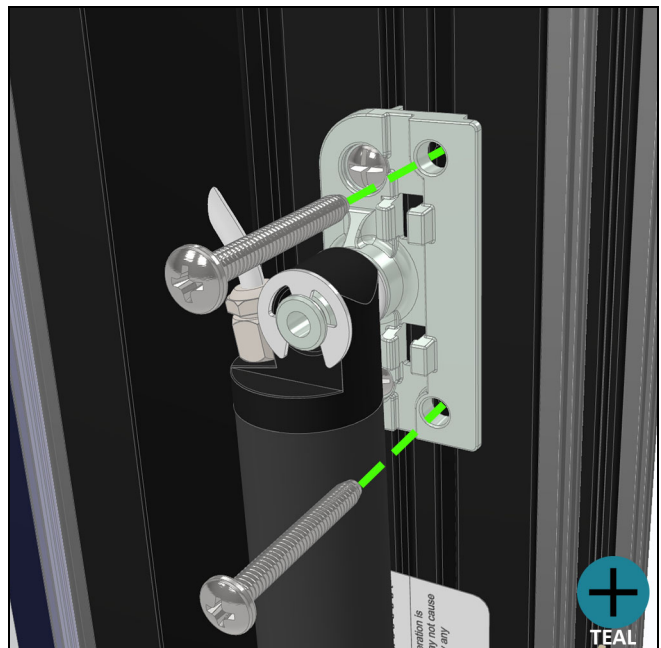

Figure 164

Special Instructions for Non-Rectangular Polygons

Any polygon with a head jamb that slopes **down and to the right** as seen from the exterior, will use a polygon bracket in the following situations:

Common shapes include but are not limited to:

- P5-1
- P3-1
- P3-5
- P4-6

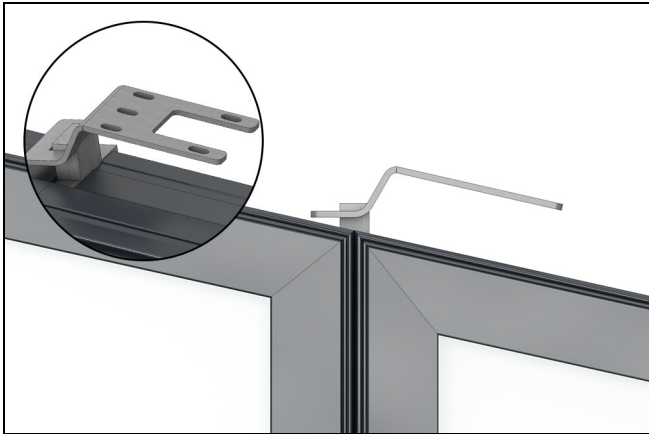

Figure 165 Exterior view

1. Flat Steel Mulls: will use the polygon bracket at the head jamb and standard bracket at the sill. See [Figure 166](#), [Figure 167](#), and [Figure 168](#).

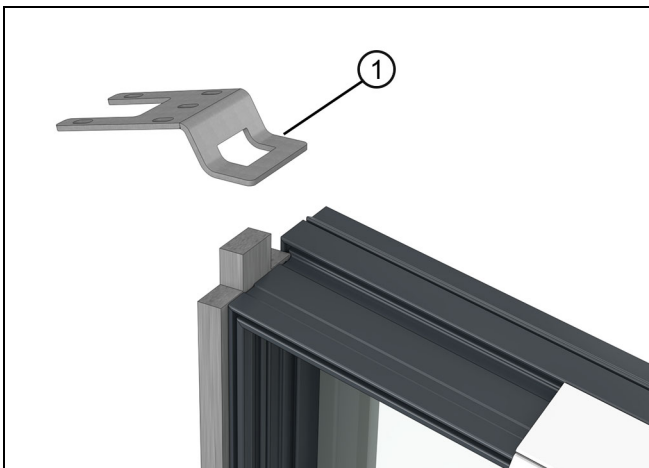

Figure 166 Interior view

1	Flat steel polygon bracket
---	----------------------------



Figure 167 Interior view

1	Flat steel polygon bracket fastened directly to RO
---	--

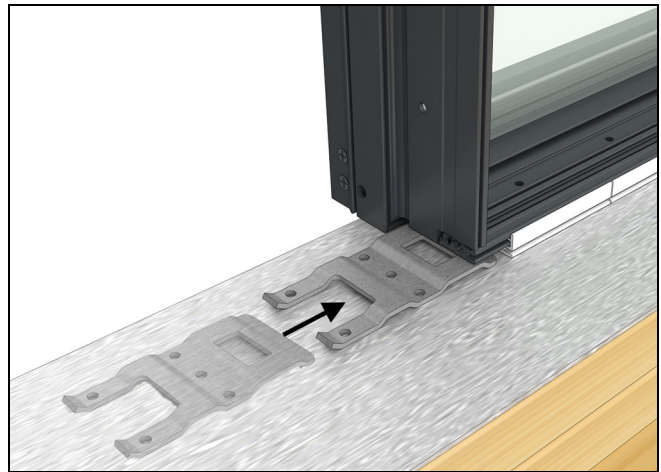

Figure 168 Standard flat steel mull bracket at sill

2. Tube Steel Mulls: will use handed brackets at the head jamb. At the sill, you will use the standard mull bracket unless you have a sloped sill in which case you will use a handed polygon bracket. See [Figure 169](#) and [Figure 170](#).

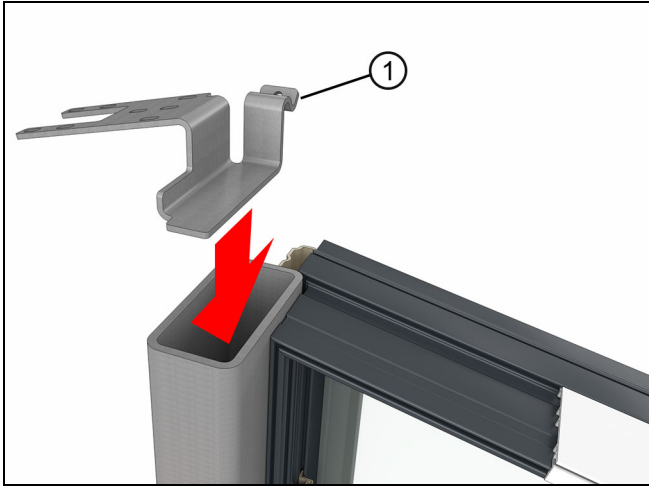

Figure 169

1	Polygon tube steel bracket
---	----------------------------

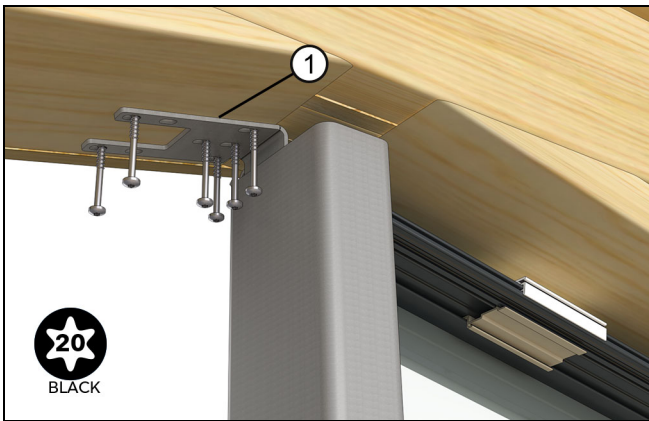

Figure 170

1	Polygon tube steel bracket and installation screws
---	--

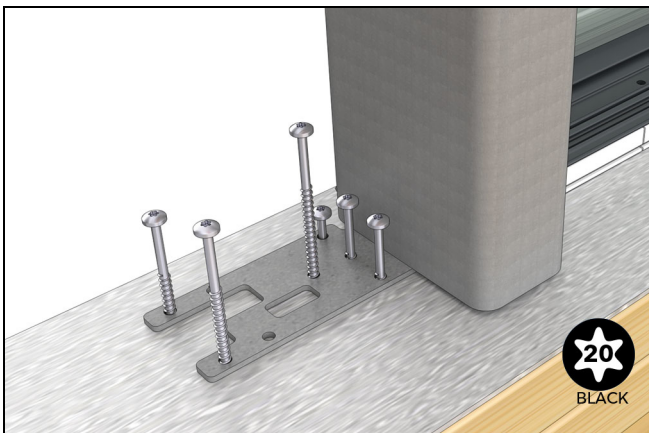

Figure 171 Regular tube steel bracket for flat sills.

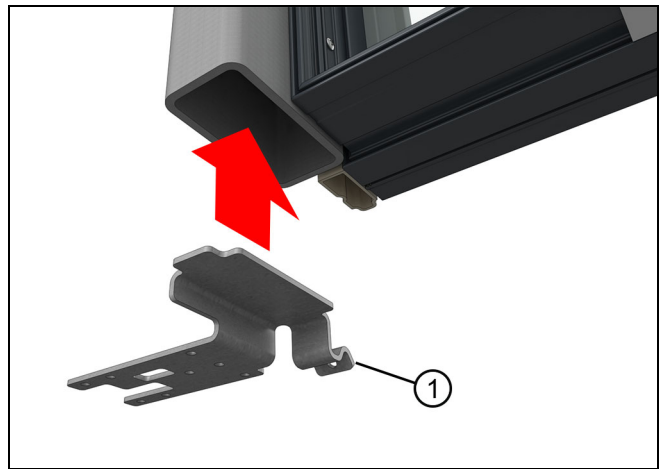

Figure 172 For angled sills only.

1	Polygon tube steel bracket used on angled sills
---	---

3. Any Non-rectangular Polygon with a rough opening less than 1/2" will likely require that you modify the bracket at the sloped head jamb to allow for clearance. Bend the brackets at the locations indicated in [Figure 173](#) below.

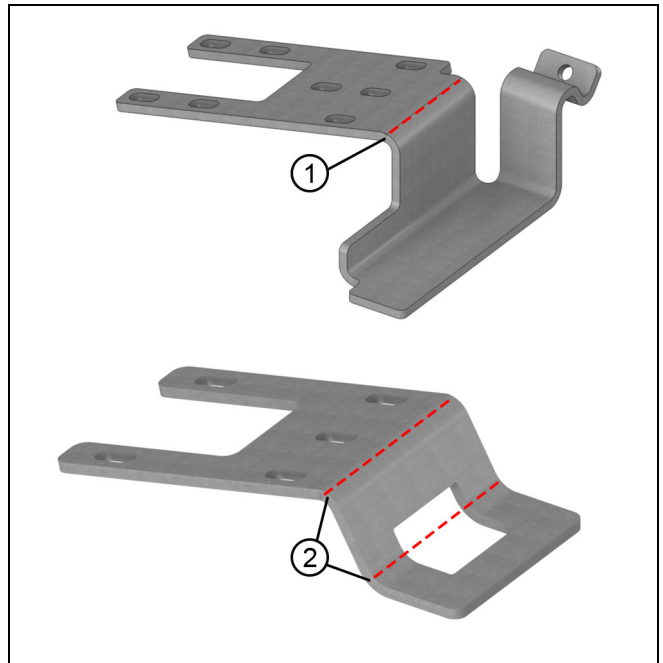

Figure 173

1	Tube steel bracket bend
2	Flat steel bracket bends

Swinging Door Flat Steel Mulling

Using a smartphone or similar device, scan the QR code or click [here](#) to play a video of this procedure.



Tools and Supplies Needed

- 1/2" x 4" (13 x 102) OR 1/2" x 2 1/2" (13 x 64) **primed** flat steel (spec listed below)
- 1/8" (3) drill bit for drilling into steel plate
- #23 drill bit (.154 inches or 3.911mm) for drilling into steel plate
- Power drill/driver
- Phillips head bit
- Drill stop collar
- Level
- Clamps
- Rubber mallet
- Tape Measure

Steel Specification: ASTM A36/GR50 Steel or better.

- Scratch awl or tool for marking steel

Parts Included

- #8-32 x 1/2" trilobular screws (frame to steel)
- #10-12 3" T20 Torx pan head 2/3 thread screws (through brackets into RO framing)
- Mull end brackets
- Mull covers
- Template for fabricating steel ends
- Dow 995 Sealant or equivalent
- CSL 343 Sealant or equivalent

Preparing Swinging Doors for Mulling

1. If not done from the factory, remove all shim blocks and nail fin on the side of frames that will be mulled.



Figure 174

2. If you are mulling to the **Inswing hinge side**, remove the two fasteners that attach the backer to the jamb and the six fasteners that attach the hinge to the backer. [See Figure 175.](#)

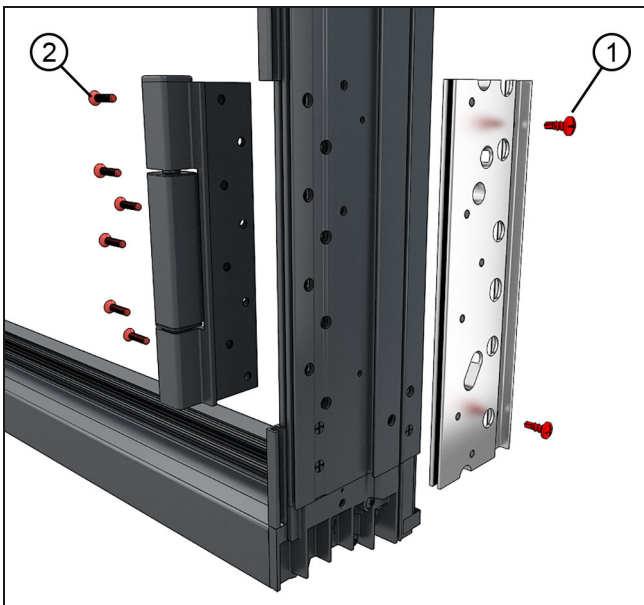

Figure 175

1	Remove screws that attach the backer
2	Remove screws that attach the hinge

3. Start with a flat and level opening. [See Figure 6.](#)

4. Establish an exterior plane along the sill. Use a laser level or snap-line. This will be helpful for larger multiple wide assemblies. [See Figure 6.](#)

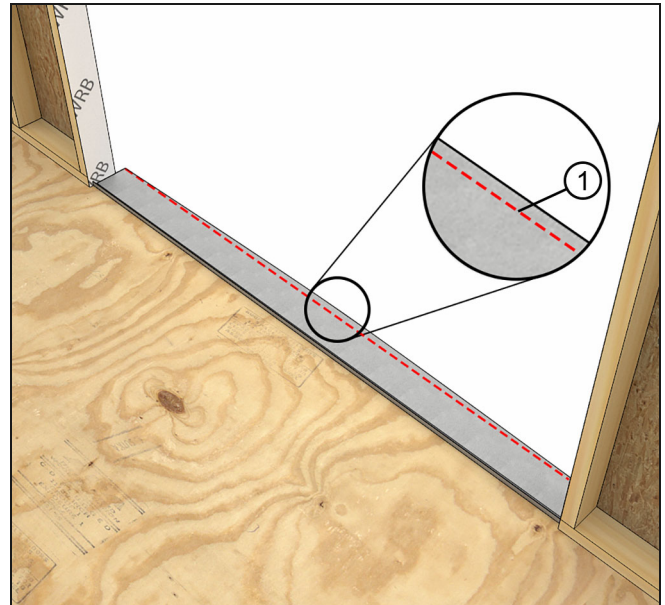

Figure 176

Flat Steel Mulling-Door to Window

IMPORTANT

As seen from the exterior, you will install the assembly in the opening in a left to right fashion unless stated otherwise.

1. For configurations where the first unit you install in an opening is a door, measure $5 \frac{3}{16}$ " away from the rough opening and install the sill support $3 \frac{5}{16}$ " from the exterior sheathing line. See Figure 177.

IMPORTANT

$5 \frac{3}{16}$ " measurement is based on a $\frac{3}{4}$ " rough opening gap. Adjust this measurement accordingly if you are using less than $\frac{3}{4}$ ".

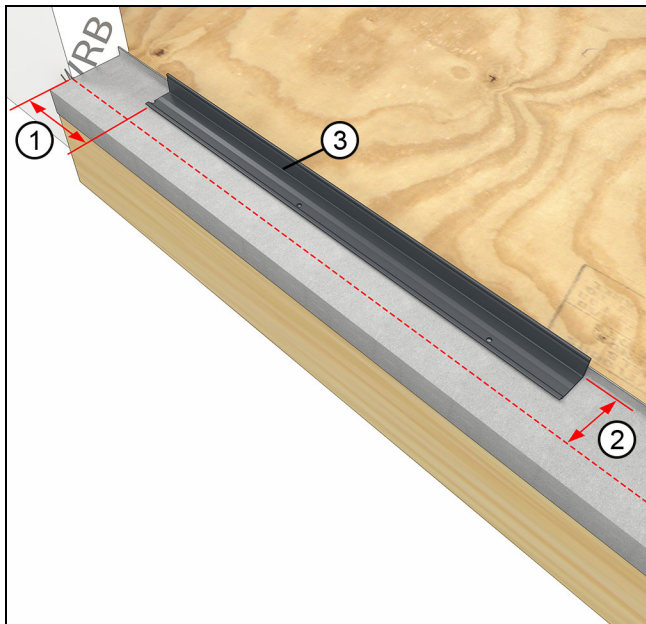

Figure 177

1	$5 \frac{3}{16}$ " (132)
2	$3 \frac{5}{16}$ " (84)
3	Sill support

2. Position the first unit in the opening. Shim and plumb the first jamb on the desired vertical plane, then fasten and shim along the jamb with screws into the rough opening. See Figure 178.



Figure 178 Hinge jamb shown

1	Shim
2	# 10x 3" flat head screw (through hinge)

3. Temporarily position the mull bracket on the sill. You will need shim to get the bracket to the correct height if the unit does not sit flat on the sill plate. The bracket should sit flush with the bottom of the frame/shim block.

IMPORTANT

If the unit to the right is a window, use the XX bracket. If the unit to the right is another door, use the YYY bracket.

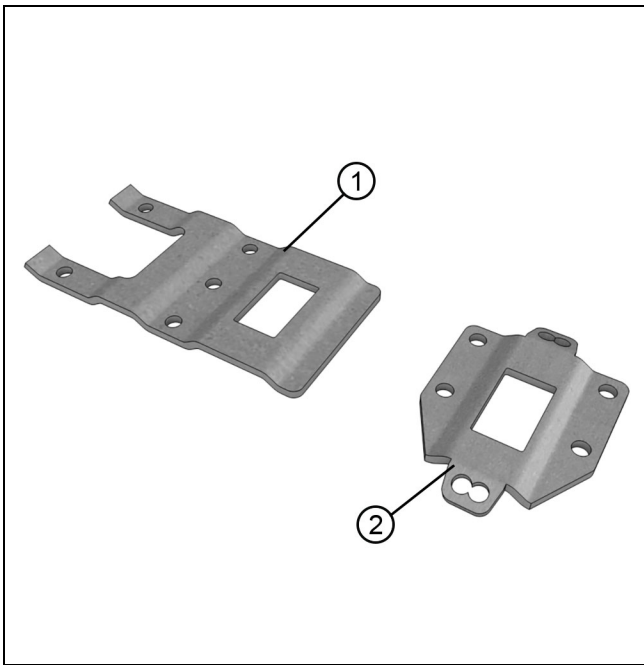

Figure 179

1	Window mull bracket
2	Door mull bracket



Figure 181 Hinge jamb shown

1	Shim
2	# 10x 3" flat head screw (through hinge)

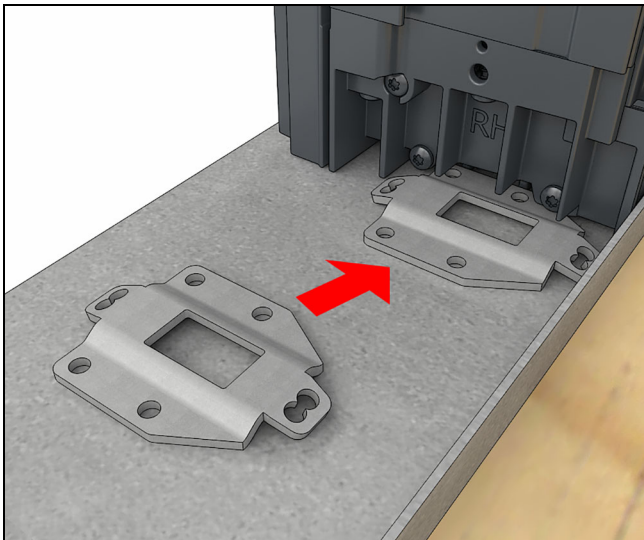

Figure 180

4. Position the first unit in the opening. Shim and plumb the first jamb on the desired vertical plane, then fasten and shim along the jamb with screws into the rough opening. See Figure 178.

5. Adjust the frame and bracket so it is square in the opening.



Figure 182

6. Predrill, and fasten the bracket using #10-12 3" T20 Torx pan head 2/3 thread screws or similar depending on the sill material.

NOTE: The front and back holes in the bracket should be angled toward the center of the bracket.

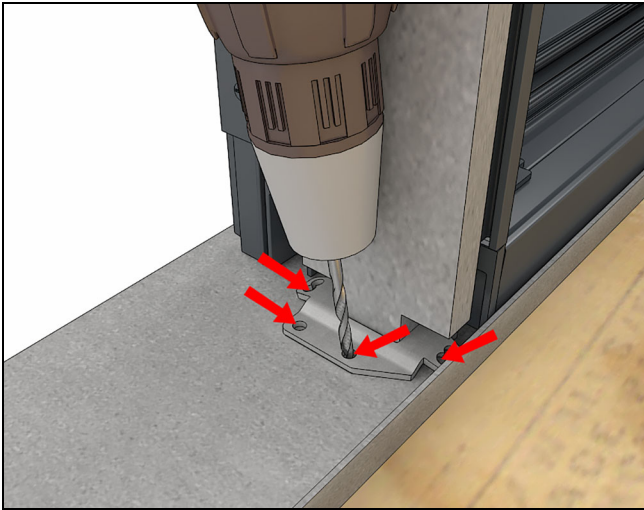

Figure 183

NOTE: If you are drilling into a sill pan or prepared sill with water management it is highly advised to pre-drill and inject sealant in the screw holes prior to fastening the sill bracket.

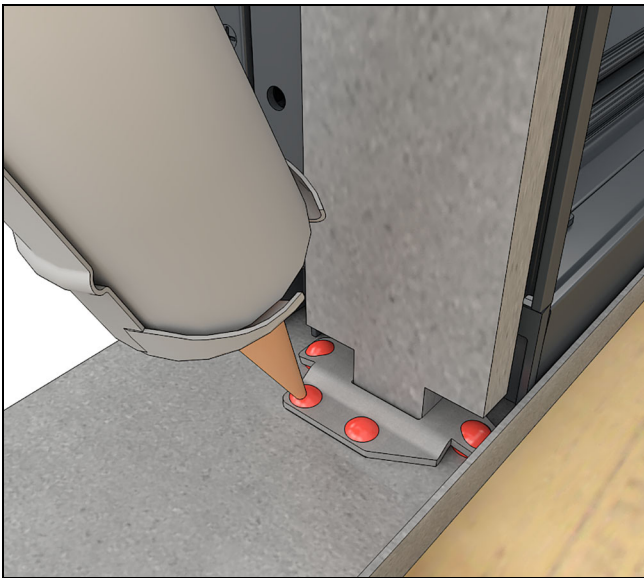

Figure 184

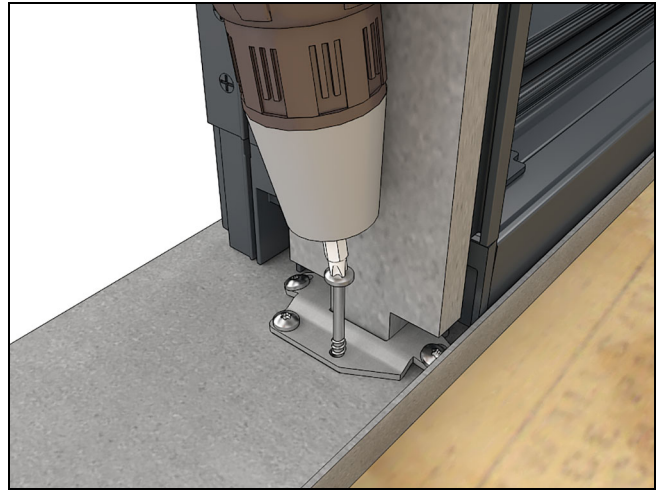

Figure 185

7. Slide the top mull bracket so that it fits over the tab on the mull steel.

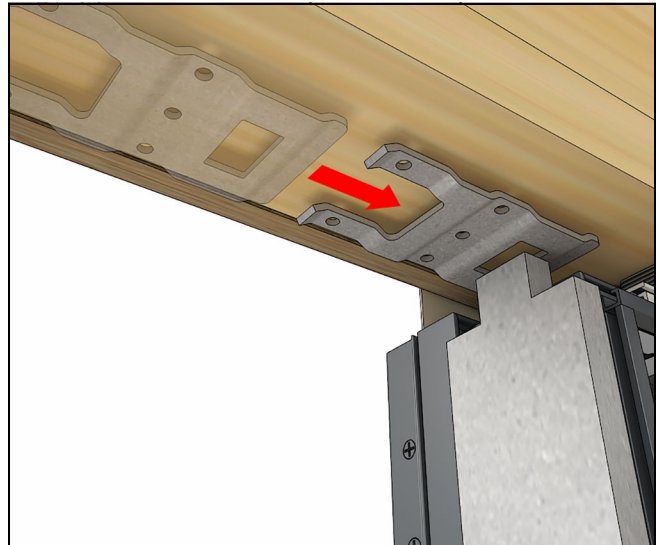

Figure 186

8. Shim the top bracket so that when it is fastened to the RO it will be no more than 1/8" away from the top of the frame/shim block.

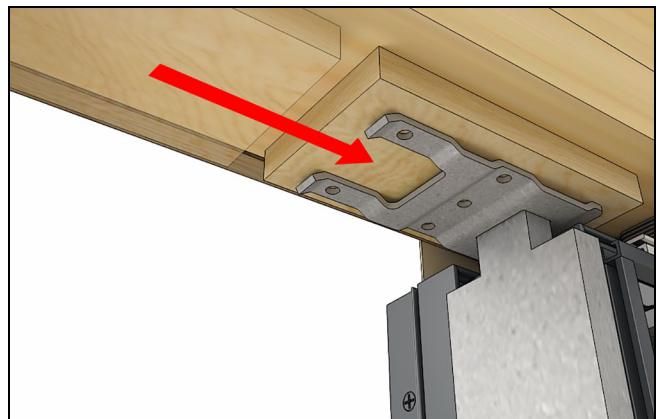

Figure 187

9. Fasten the top bracket to the RO with the 3" screws provided.

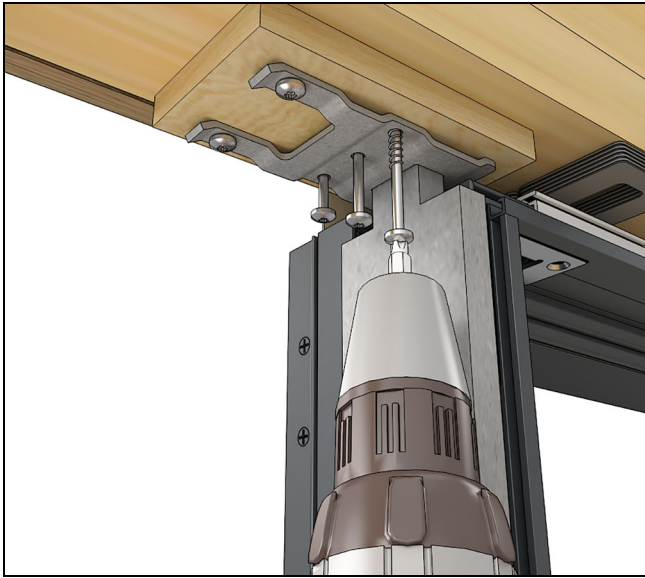

Figure 188

10. Using the pre-drilled installation holes in the frame as a guide, drill through the steel with a #23 bit. Refer to the table in [step 11 on page 50](#).

NOTE: You may need to first drill with a 1/8" bit.



Figure 189

11. Fasten the steel to the frame with the appropriate trilobular screws following the table below.

Usage	Fastener	Drill Size
Installation Holes	#8 x 1/2" trilobular screws	#23 (.154")
Strike holes and panel alignment bolts	#8 x 7/8" color matched trilobular screws	#23 (.154")
Hinge holes and stationary brackets	#10 x 7/8" color matched trilobular screws.	#18 (.169") 11/64" (.171) accepted

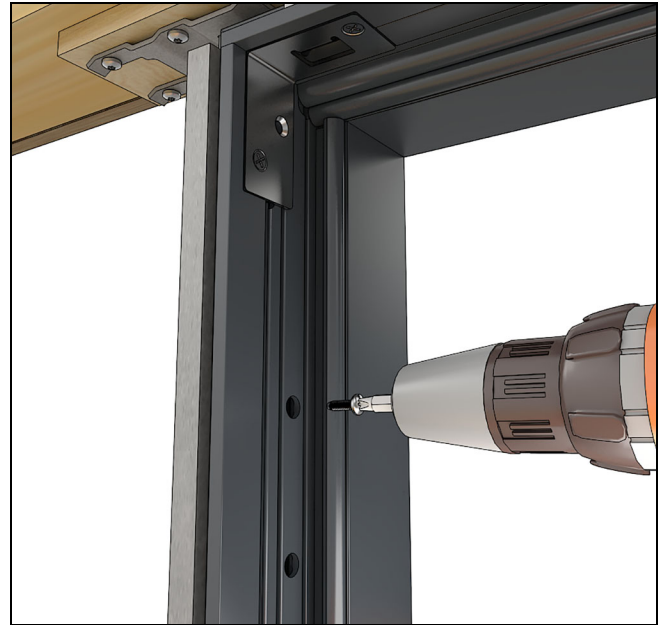

Figure 190

12. Using the pre-drilled hardware holes in the frame as a guide, drill through the steel with the appropriate bit. Use the table in [step 11 on page 50](#) as a guide.

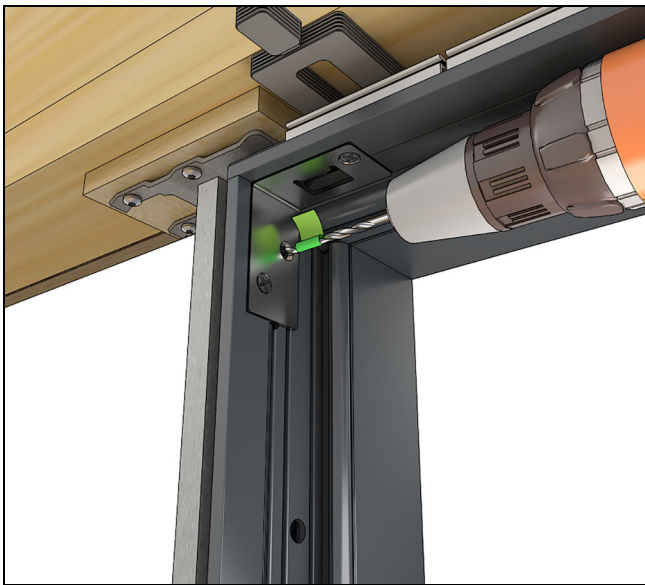

Figure 191

13. Install the appropriate trilobular fasteners to attach through the hardware and frame into the steel (attached to the unit next to it). Refer to the table from [step 11 on page 50](#) for the appropriate fastener.

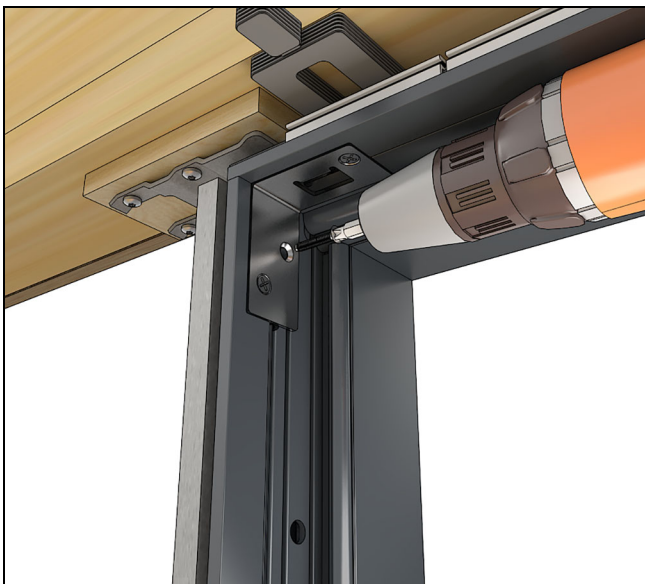

Figure 192

1	#8x 7/8 trilobular screws
---	---------------------------

14. Apply a 1/4" bead of structural sealant beside the exterior frame accessory kerf along the entire length of the mull.

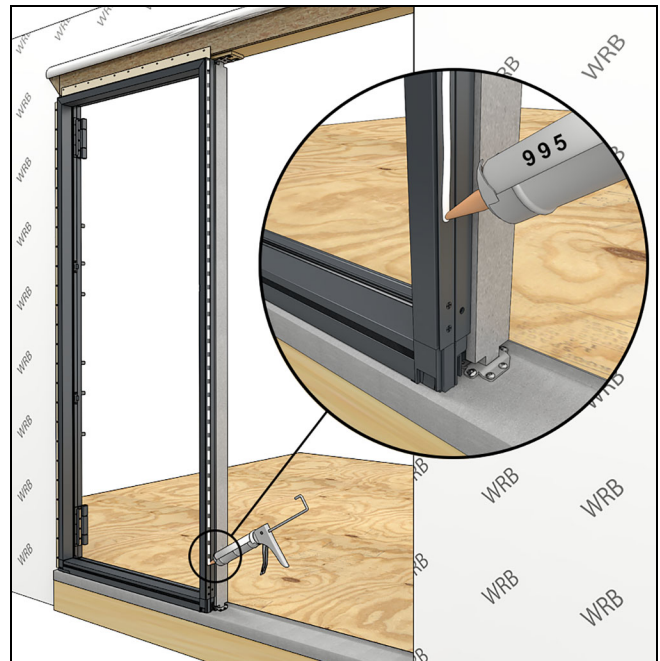

Figure 193

15. When the next unit in the assembly is a door, measure 4 7/16" (113) from the jamb of the first door. Make a mark and install the second sill support at this location, 3 5/16" (84) from the exterior sheathing line. See [Figure 194](#).

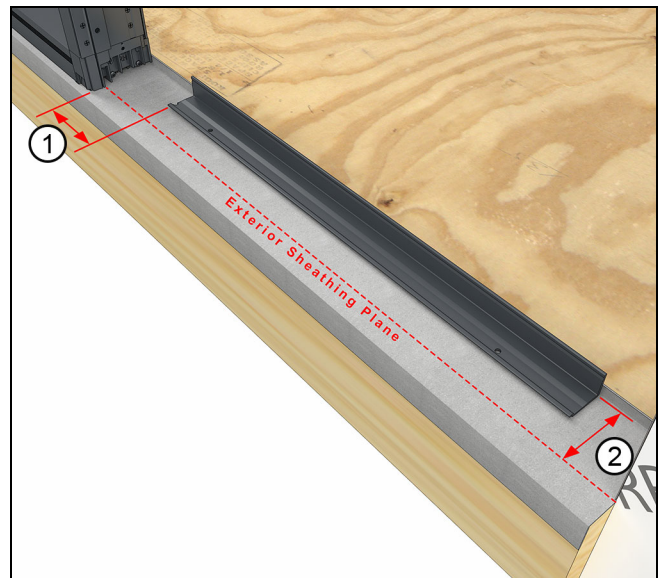

Figure 194

1	4 7/16" (113)
2	3 5/16" (84)

16. Set the second unit in place in the opening. Align the frames and clamp.

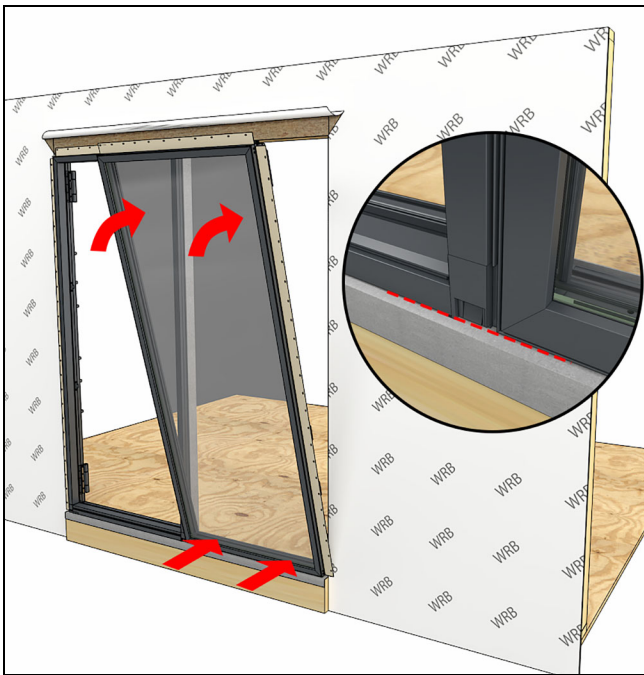

Figure 195



Figure 196

IMPORTANT

Verify the sealant has made contact with both frames before proceeding.

17. Install the exterior mull cap. Seat in place with a rubber mallet.

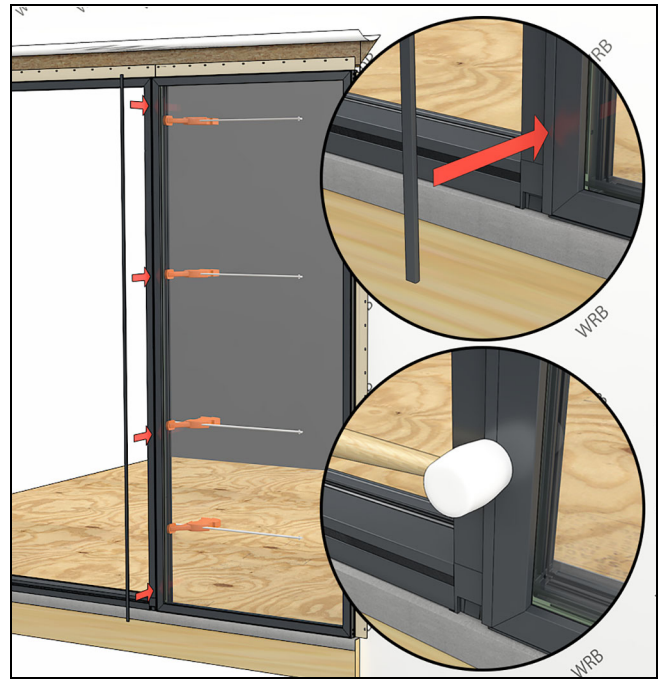

Figure 197



Hint

Clean any excess sealant off the frame at this time.

IMPORTANT

Confirm that the installation holes on opposite sides of the mull are offset from each other (vertically). If not, drill new holes through the frame at least 1/2" away from the original installation holes

18. Using a drill with a stop collar use the installation holes as a guide and bore into the steel with a #23 drill bit. Note the depth of the stop collar for different products. See Figure 198.

IMPORTANT

Do not bore through the steel and into the opposite framing.

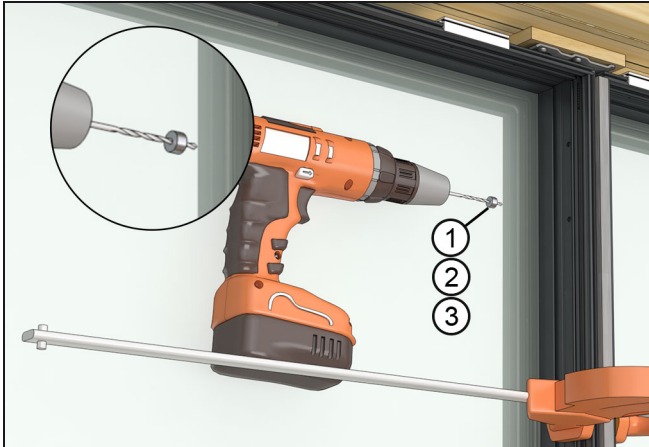

Figure 198 Use stop collar to determine depth. See table below

1	DG: #23 drill bit with stop collar set to 5/8" depth
2	Casement: #23 drill bit with stop collar set to 1 1/4" depth
3	Doors: #23 drill bit with stop collar set to 1" depth

19. Fasten the second frame to the mull steel using the #8 x 1/2" trilobular screws included. See Figure 199.



Figure 199

20. Making sure all the frames are aligned along the correct exterior plane, fasten the head jamba with #10 x 3" T20 Torx pan head installation screws. See Figure 200.



Figure 200

21. Using the hardware holes as a guide, drill into the steel with the appropriate bit. Use the table in step 11 on page 50 for reference.

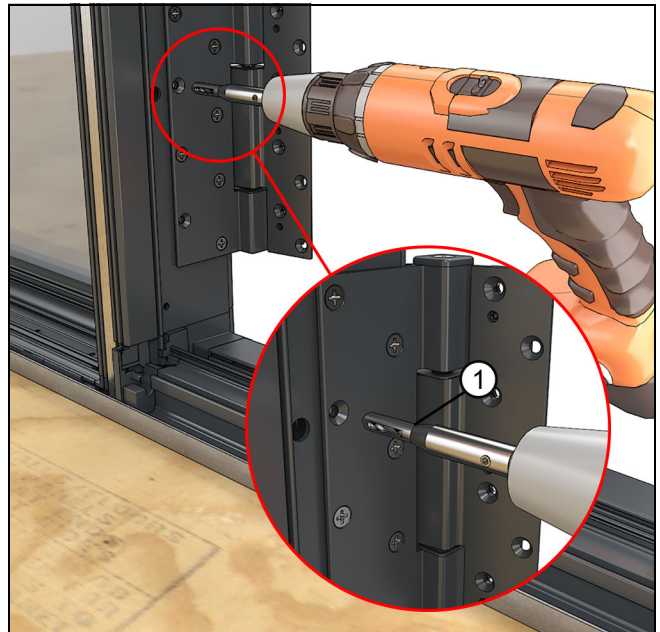

Figure 201

22. Install the appropriate trilobular fasteners to attach through the hardware and frame into the mull pin (attached to the unit next to it). See Figure 202 through Figure 205. See the table from step 11 on page 50 for appropriate fasteners and locations.

 **Tip**

Adjust the clutch on your drill to avoid stripping out fasteners.

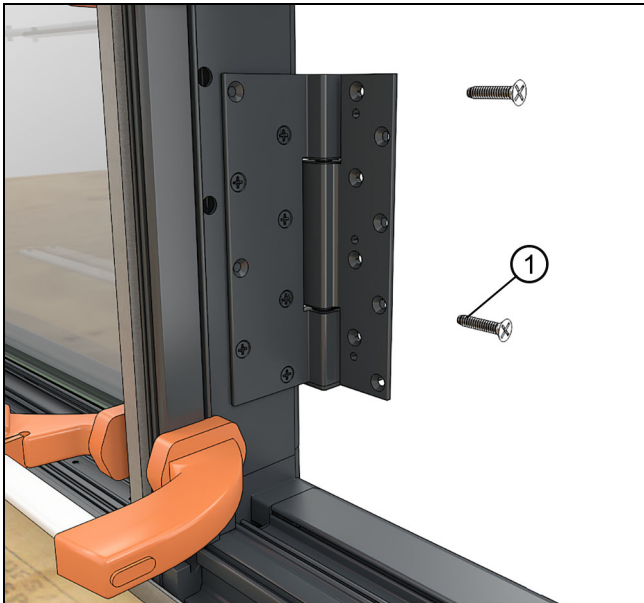

Figure 202 Outswing hinges shown.

1	#10 x 7/8" trilobular screw
---	-----------------------------



Figure 203 Inswing stationary brackets.

1	#10x 7/8" trilobular screw
---	----------------------------

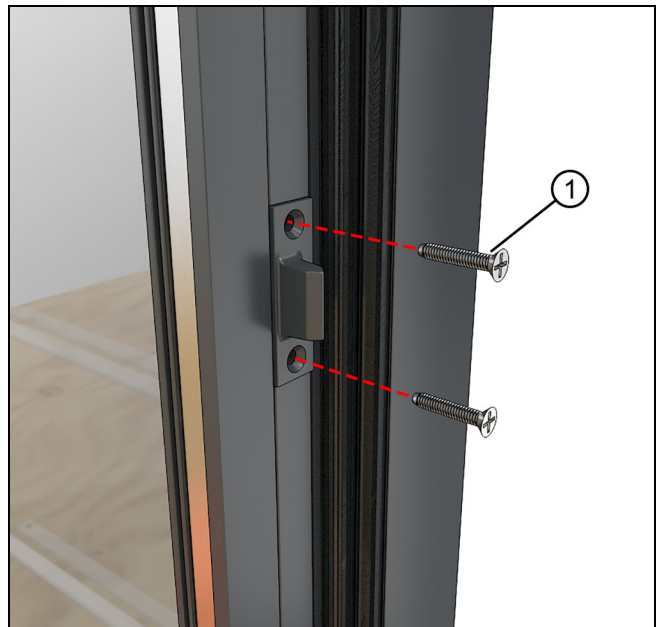

Figure 204 Fasten panel alignment bolts.

1	Panel alignment bolt holes: #8 x 7/8" trilobular screws
---	---

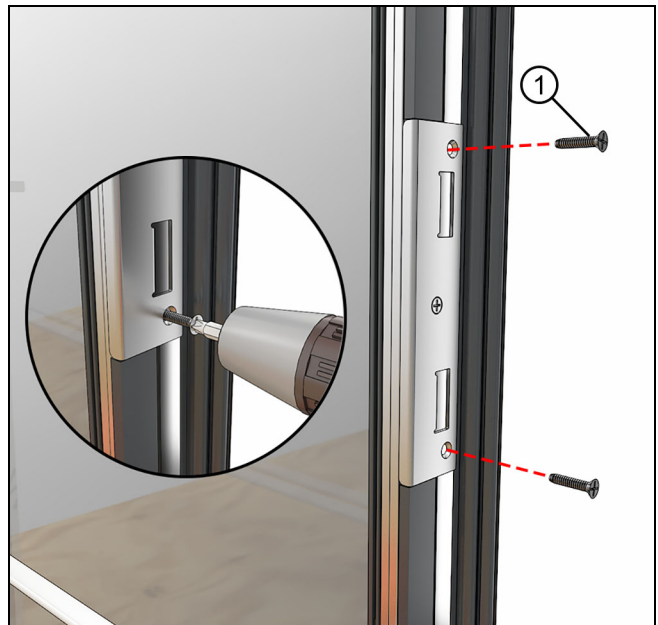

Figure 205 Fasten strikes

1	#8 x 7/8" trilobular screws
---	-----------------------------

23. Complete fastening around the perimeter at the remaining installation holes. Maintain a square and plumb installation and shim at every fastener location between the frame and the rough opening. [See Figure 206.](#)



Figure 206

24. Fasten strikes, panel alignment bolts, hinges, and stationary brackets to the rough opening. Shim at all fastener locations between the frame and the rough opening. See Figure 207, Figure 208 and Figure 209.



Figure 207 Inswing Hinges shown

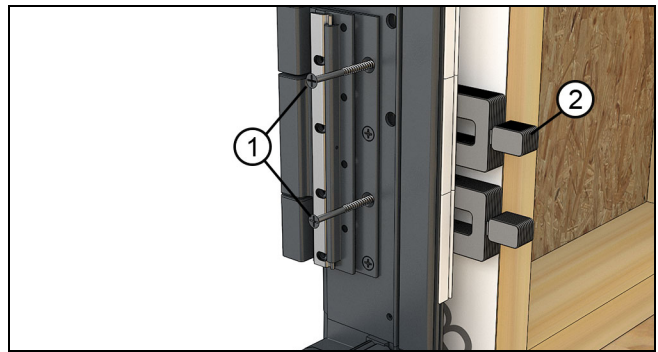

Figure 208 Outswing

1	#10 x 3" 2/3 thread Phillips flat head screws
2	Shims

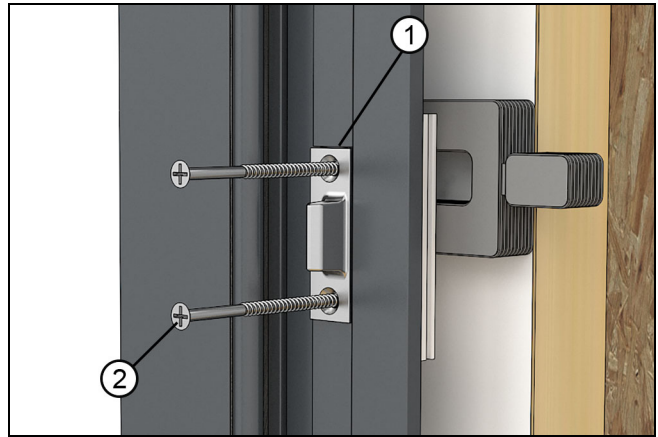

Figure 209

1	Panel alignment bolt
2	#8 x 3" 2/3 thread Phillips flat head

25. Repeat procedures starting with step 3 on page 47 for consecutive units.

26. Install the interior mull cap(s). Seat with a rubber mallet. See Figure 210.

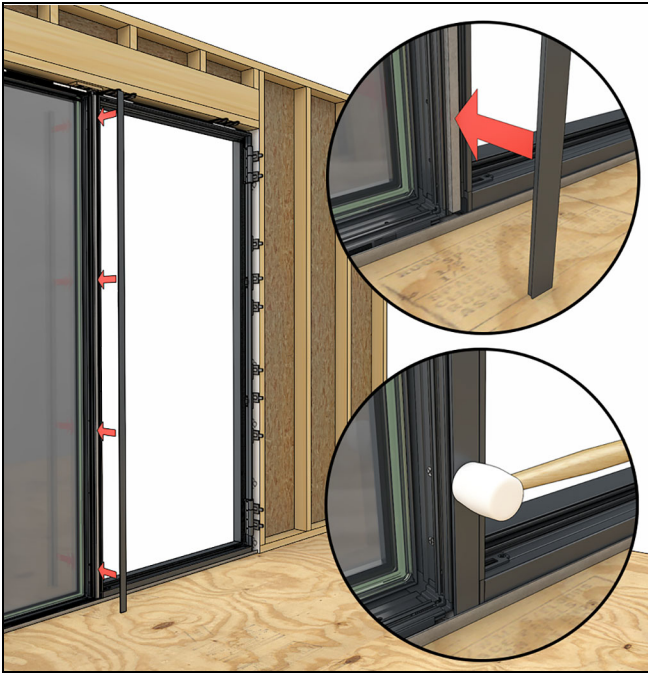

Figure 210

Swinging Door Tube Steel Mulling

Tools and Supplies Needed

- 2" x 4" x 3/16" wall (51 x 106 x 4) **primed** tube steel (spec listed below)
- 1/8" (3) drill bit for drilling into steel tube
- #23 drill bit (.154 inches or 3.911mm) for drilling into steel tube
- #18 drill bit (.169 inches or 4.3mm) for drilling into steel tube. 11/64" (.171) accepted.
- Power drill/driver
- Phillips head bit
- Level
- Clamps
- Rubber mallet
- Screen spline roller
- Tape Measure

Steel Specification: ASTM A500B Steel or better.

IMPORTANT

Strikes on operating outswing X configurations for locking jamb or horizontal mulls are installed from the factory. Refer to assembly instructions for details on fastening strikes.

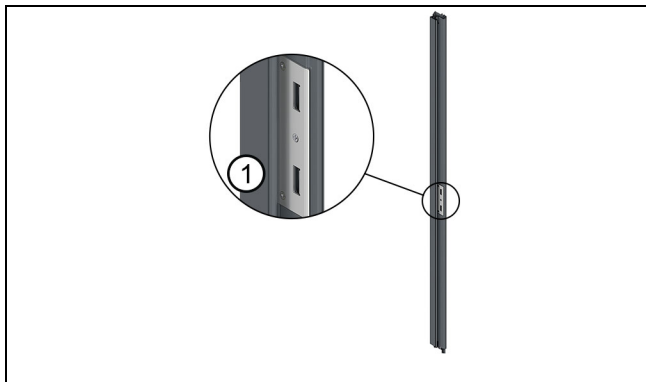

Figure 211 Outswing Locking Jamb: Strikes are installed from the factory. Support for the strike is fastened through the back of the jamb.

1	Jamb strike
---	-------------

Parts Included

- Mull Filler (V3037) and Mull Filler Blocks
- #8-32 x 1/2" trilobular screws (frame to steel)
- #10-12 3" T20 Torx pan head 2/3 thread screws (through brackets into RO framing)
- #8-32 x 1 1/4" trilobular screws (frame to steel for Casement only)
- Mull covers
- Mull end brackets
- Mull end foam blocks
- Frame kerf weatherstrip
- Dow 995 Structural sealant or equivalent

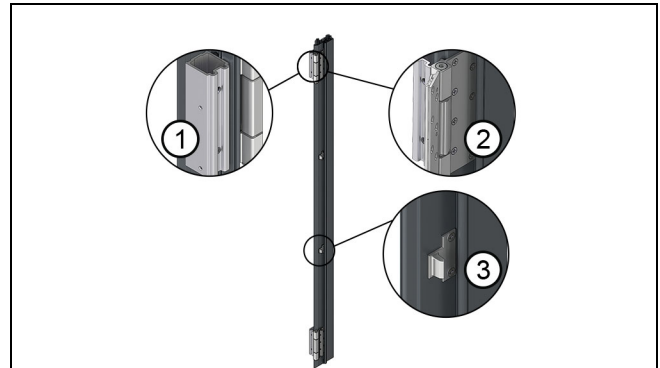

Figure 212 Outswing Hinge Jamb: Mull fillers, hinges, and panel alignment bolts are factory installed. Supports for hardware are fastened through the back of the jamb.

1	Aluminum mull filler
2	Hinges
3	Panel alignment bolts

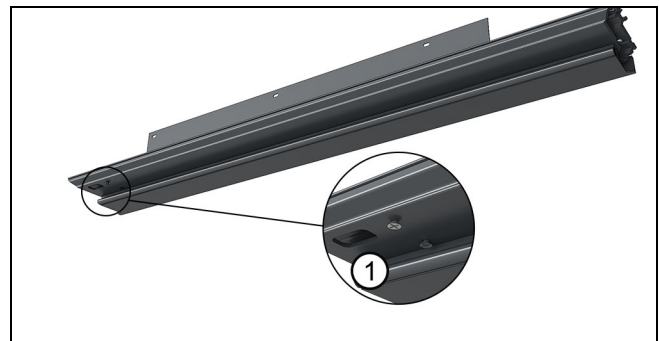

Figure 213 Outswing X Head jamb: the head jamb strike fasteners are installed from the factory. The support strike is fastened

through the back of the jamb.

1	Head jamb to jamb strike fasteners
---	------------------------------------

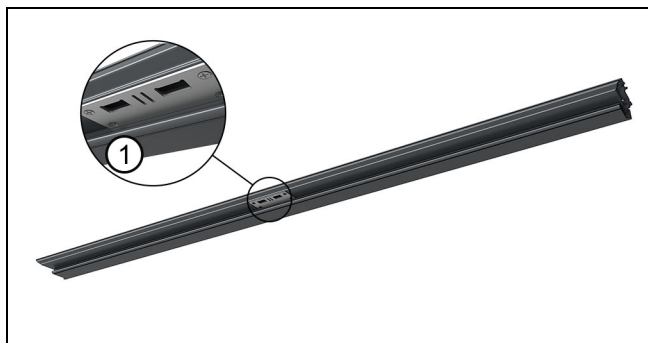

Figure 214 Outswing XX, OX, or OX Headjamb: the strike is installed from the factory.

1	Head jamb strike
---	------------------

Tube Steel Mulling Procedures

Using a smartphone or similar device, scan the QR code or click [here](#) to play a video of this procedure.



NOTE: Panel alignment bolts and hinges are fully installed on the frame when an operating outswing tube steel mull (mulled at the hinge jamb) is ordered.

1. Calculate the length of tube steel for the mull by taking the outside measurement of the frame and subtract 1/8" (3). Cut the steel to this dimension. See [Figure 215](#).

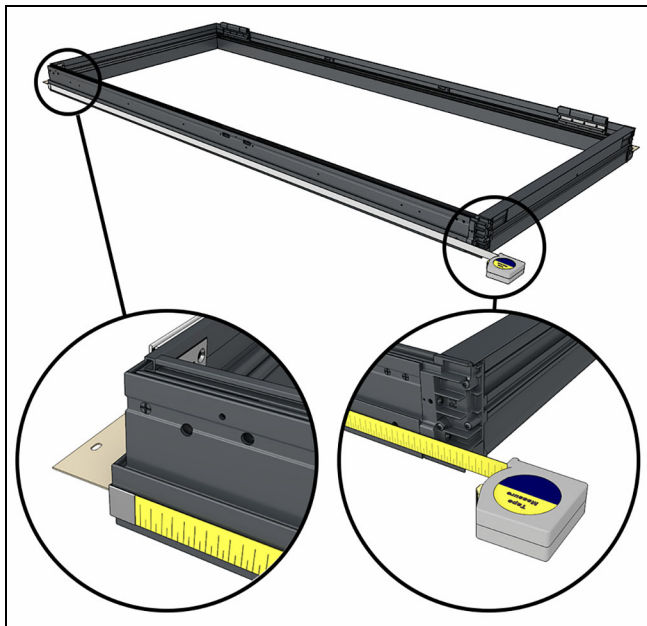

Figure 215

2. Temporarily attach mull filler blocks about 6" from frame ends of the first unit you will install. The blocks will barb into the nail fin kerf as shown in [Figure 216](#).

NOTE: NOT necessary on operating outswing hinge mulls. Aluminum mull filler blocks will be pre-installed.

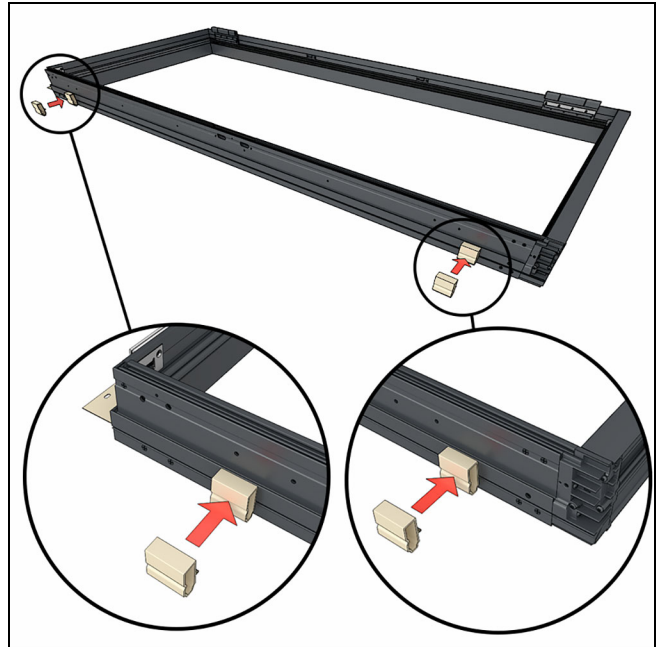

Figure 216

3. Position the first unit in the opening. Shim and plumb the first jamb on the desired vertical plane, then fasten and shim along the jamb with screws into the rough opening.

4. After the first frame (starting left to right as seen from the exterior) is secured in the opening, place the tube steel fixture on the sill, oriented so the turned up hemmed leg on the fixture fits into the frame kerf. Make sure the fixture fits flush against the sill corner key as shown. Mark the position of the sill bracket holes as shown in [Figure 217](#).

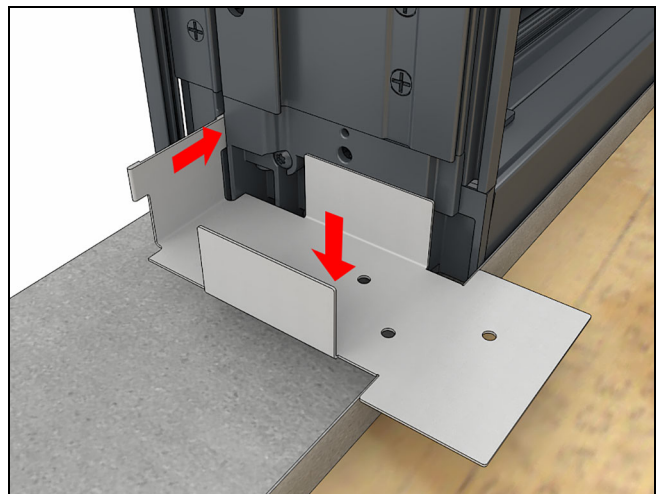

Figure 217



Hint

The fixture will also indicate where to notch your sill pan to fit the tube steel where necessary. See [Figure 218](#), [Figure 219](#), and [Figure 220](#).

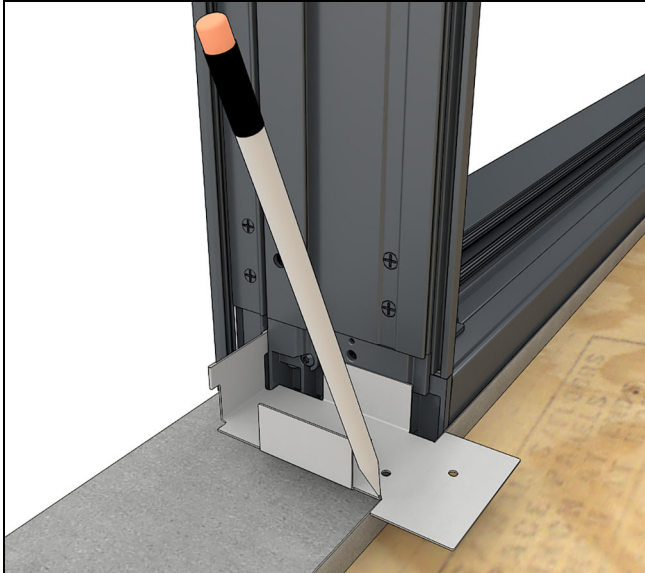

Figure 218

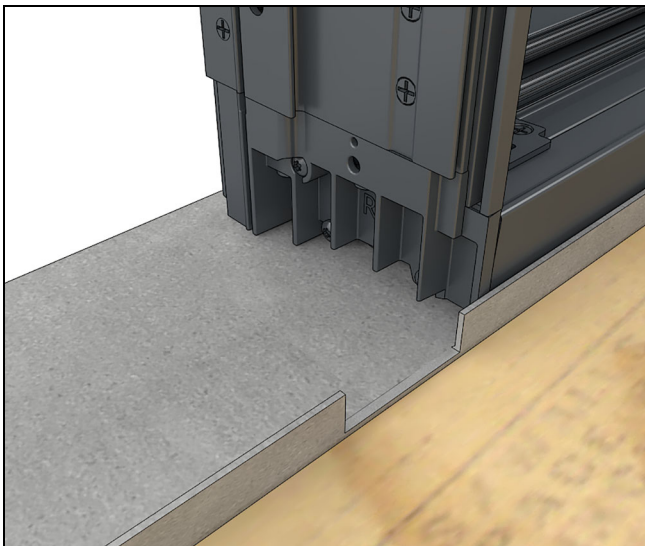

Figure 219

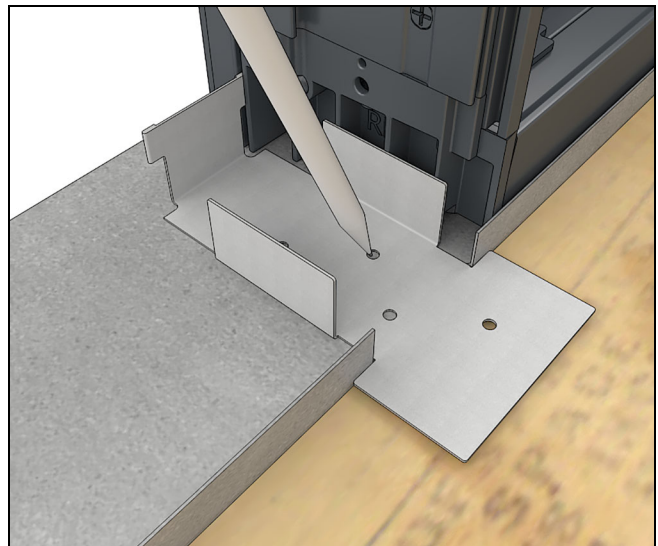

Figure 220

5. Pre-drill and fasten the sill bracket to the sill with #10 x 3" T20 Torx pan head screws. See [Figure 221](#), [Figure 222](#), and [Figure 223](#).



Tip

You may need to shim the bracket to the right height. The bracket should sit flush with the bottom of the frame.

NOTE: If you are drilling into a sill pan or prepared sill with water management it is highly advised to pre-drill and inject sealant in the screw holes prior to fastening the sill bracket.

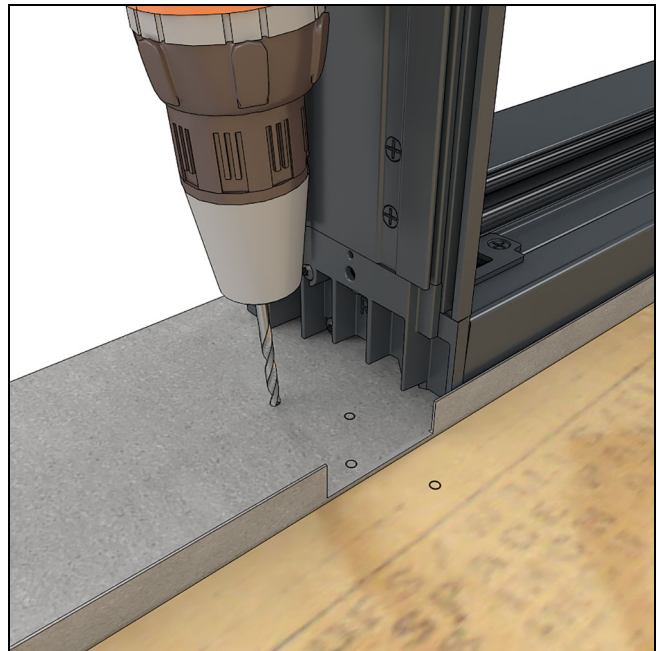

Figure 221



Figure 222 Sealant

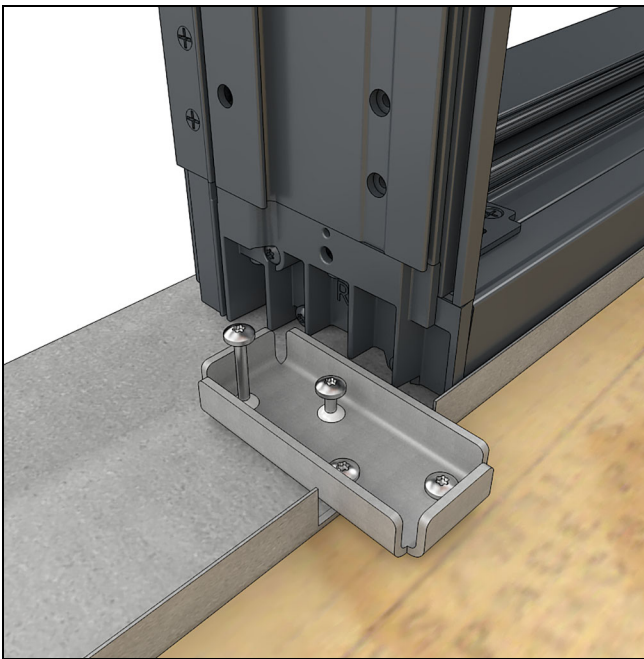

Figure 223

6. Fit the bottom of the tube steel over the flanges on the sill bracket and position the steel tight against the mull filler blocks. See Figure 224.

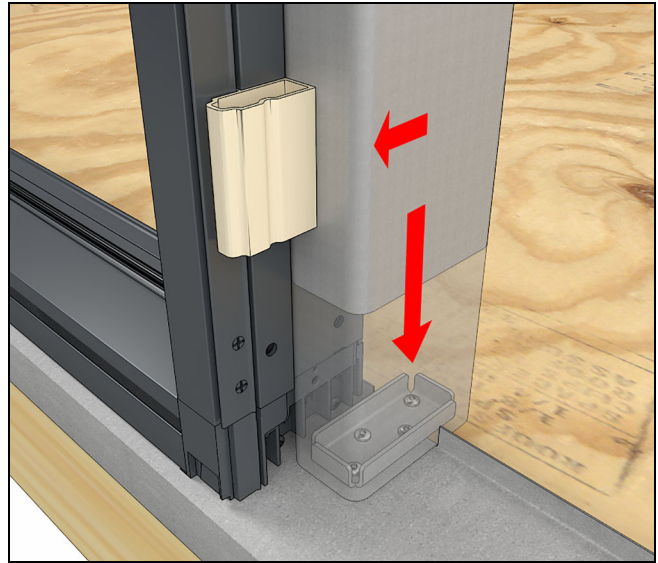

Figure 224

7. Clamp the tube steel to the frame. See Figure 225.



Figure 225

8. Slide the top bracket above the tube steel and insert into the top as shown in Figure 226.



Figure 226

9. Shim the top bracket so that when it is fastened to the RO it will be no more than 1/8" away from the top of the frame/shim block. See Figure 227.

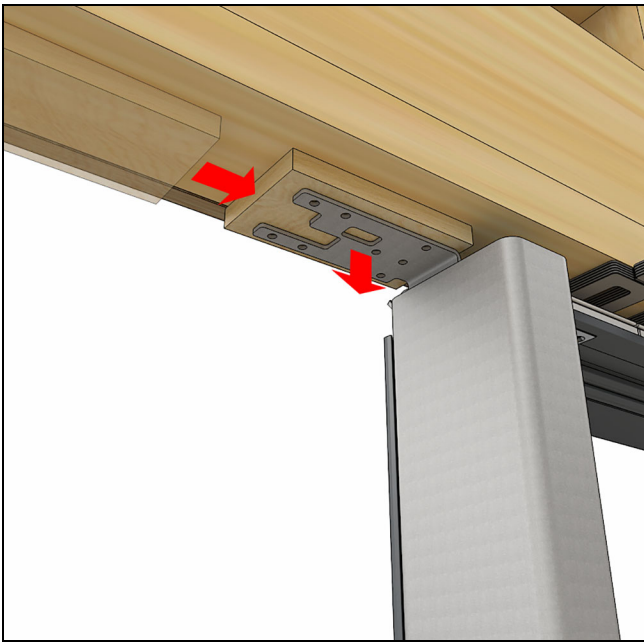

Figure 227

10. Fasten the top bracket to the RO with the #10 x 3" T20 Torx pan head screws provided. See Figure 228.

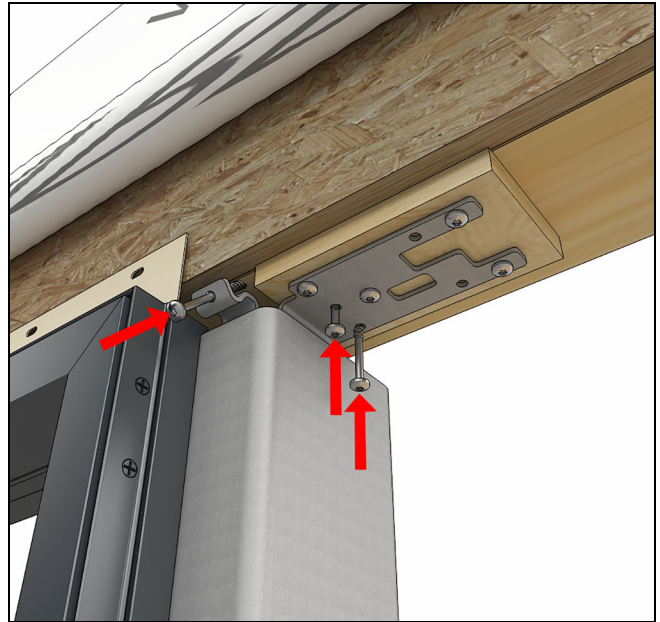

Figure 228

11. Using the pre-drilled installation holes in the frame as a guide, drill through the steel with a #23 bit. See Figure 229.

NOTE: You may need to first drill with a 1/8" bit.

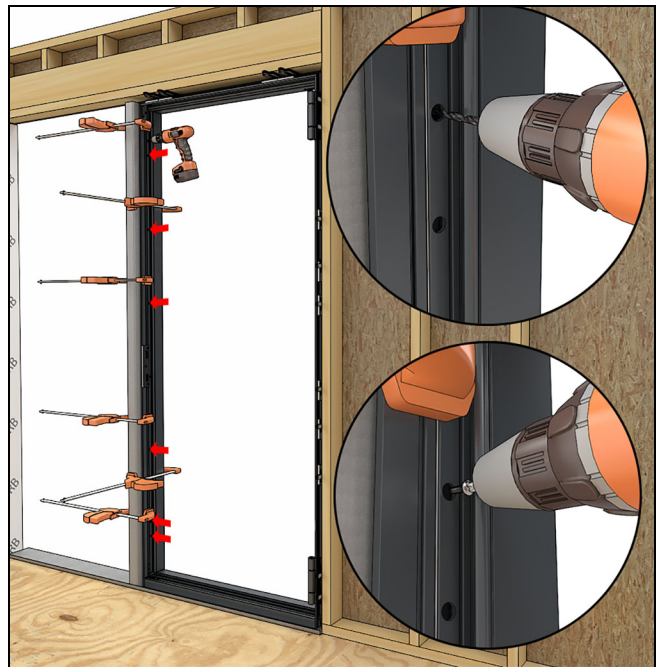

Figure 229

12. Fasten the steel to the frame with the appropriate trilobular screws following the table below. See Figure 230. For operating outswing hinge mulls, refer to Special Instructions for Operating Outswing Hinge

Mulls on page 69 to fasten the tube steel to the mull filler blocks.

Usage	Fastener	Drill Size
Installation Holes	#8 x 1/2" trilobular screws	#23 (.154")
Strike holes and panel alignment bolts	#8 x 7/8" color matched trilobular screws	#23 (.154")
Hinge holes and stationary brackets	#10 x 7/8" color matched trilobular screws.	#18 (.169") 11/64" (.171) accepted



Figure 230

1	38 x 1/2" trilobular screws
---	-----------------------------

13. Using the pre-drilled hardware holes in the frame as a guide, drill through the steel with the appropriate bit. Use the table in step 12 on page 62 as a guide. See Figure 231.

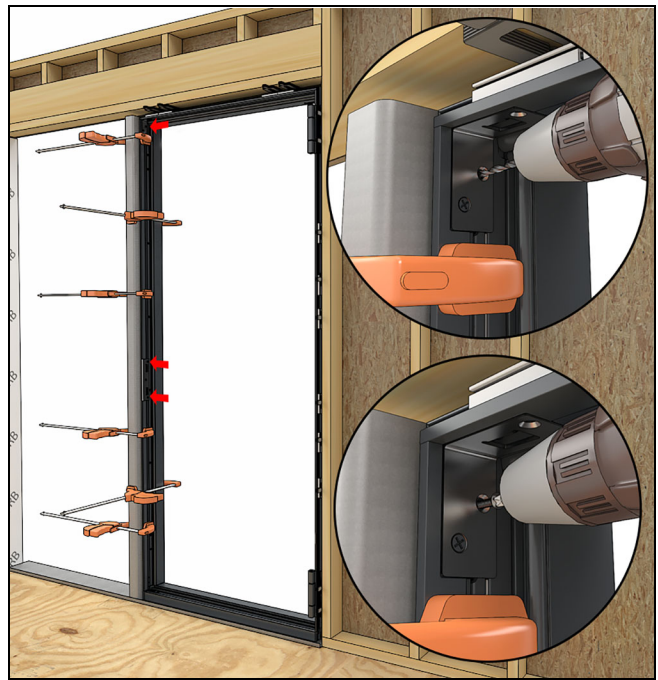

Figure 231

14. Remove the temporary mull filler blocks and replace with a full length block. See Figure 232 and Figure 233.

NOTE: Do not do this on outswing hinge mulls.

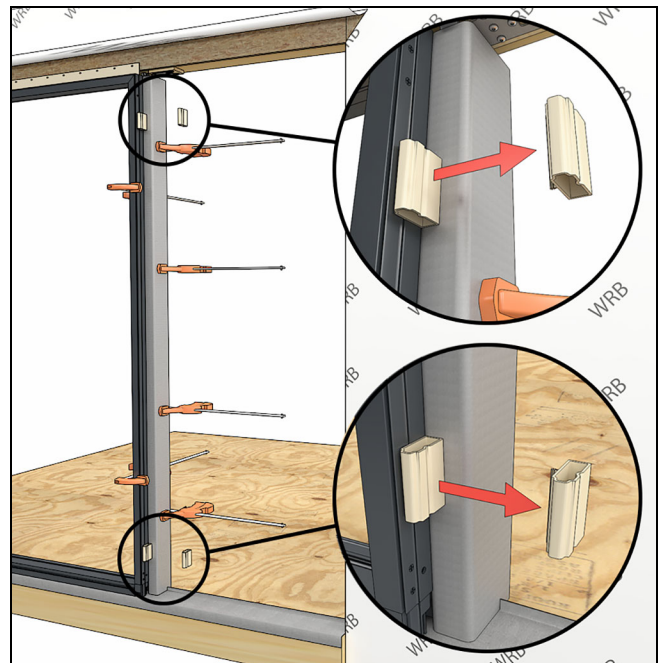

Figure 232

 **Hint**

In some cases you may need to cut the foam block in half and insert into the end of the mull filler prior to installing the filler.

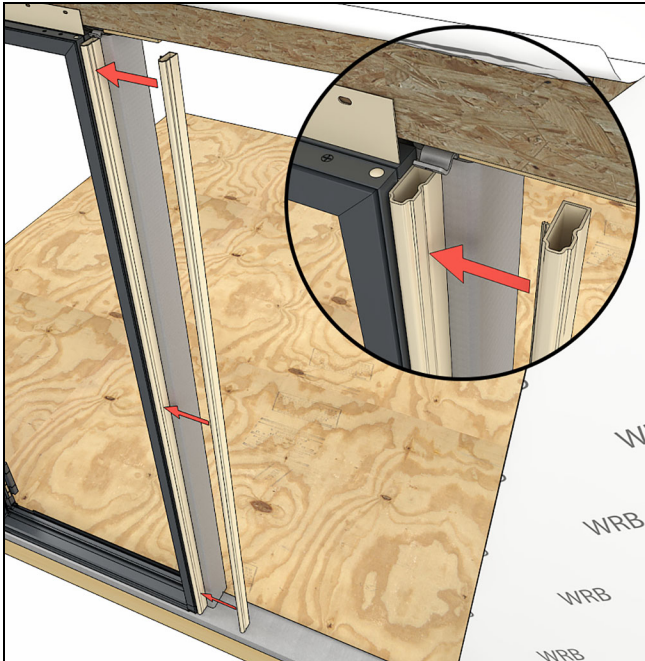

Figure 233

15. If the second unit you are installing is a door, measure 5 15/16 (151) from the first frame and install a sill support bracket. See Figure 234.

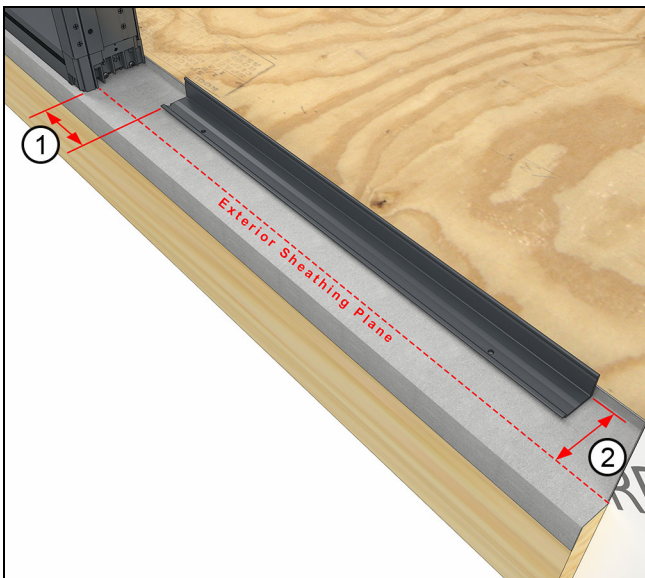

Figure 234

1	5 15/16" (50)
2	3 5/16" (84)

16. Set the second unit in place in the opening. Align the frames and clamp. See Figure 235 and Figure 236.

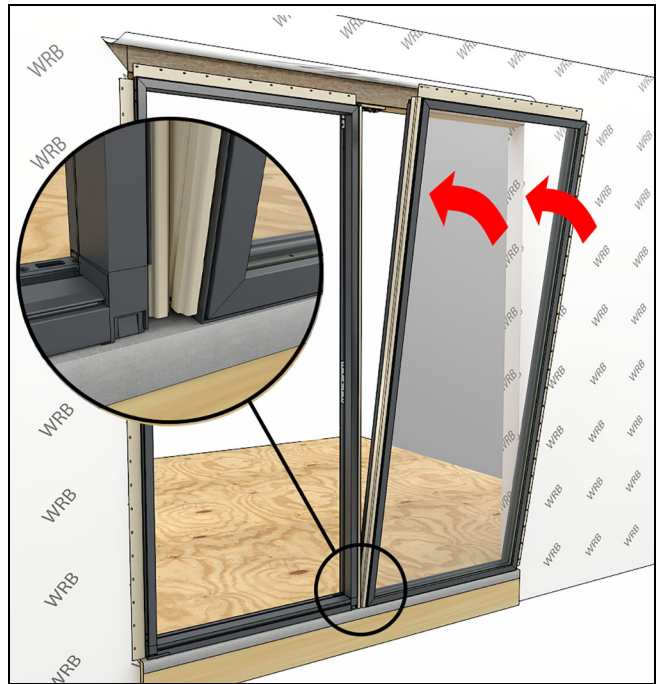

Figure 235



Figure 236

17. Making sure the second frame is aligned along the correct exterior plane, shim and fasten the head jamb through the pre-drilled holes in the frame. See Figure 237.

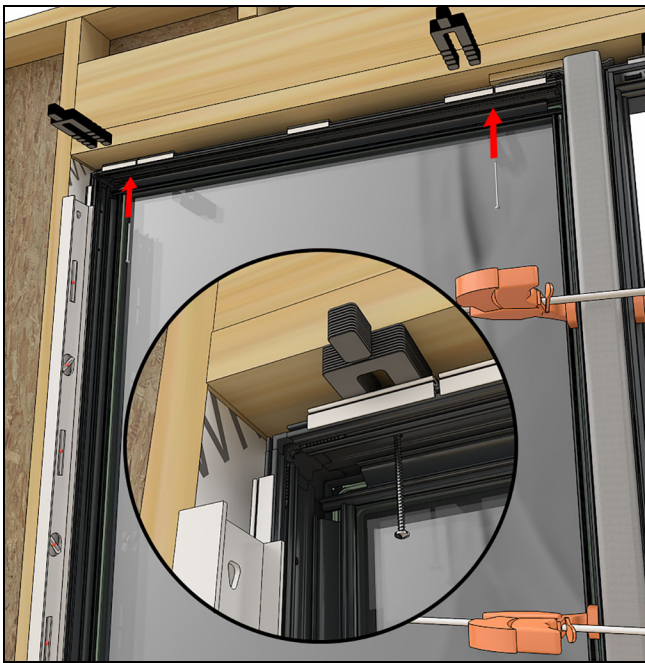

Figure 237

18. Using the pre-drilled installation holes in the frame as a guide, drill through the steel with a #23 bit. See Figure 238.

NOTE: You may need to first drill with a 1/8" bit.



Figure 238

19. Fasten the second frame to the mull steel using the #8 x 1/2" trilobular screws included. See Figure 239.

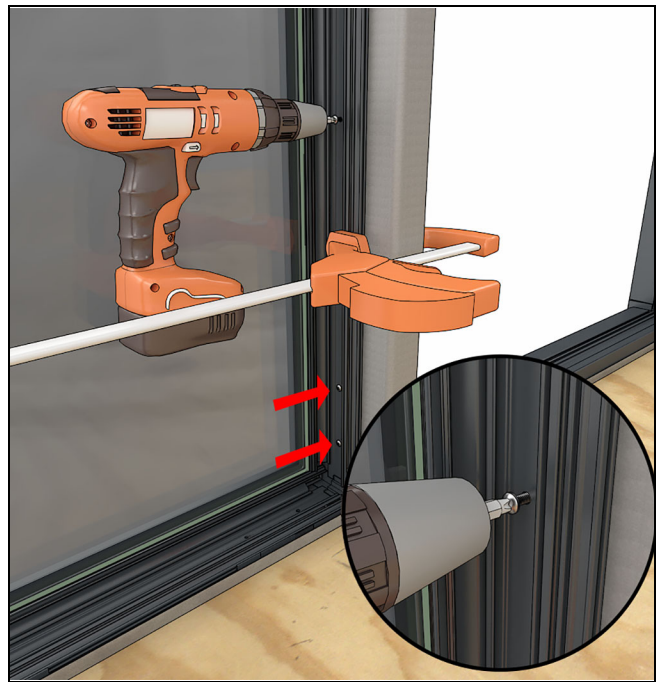

Figure 239

20. Square and plumb the second frame in the opening and then shim and fasten the jamb. See Figure 240.

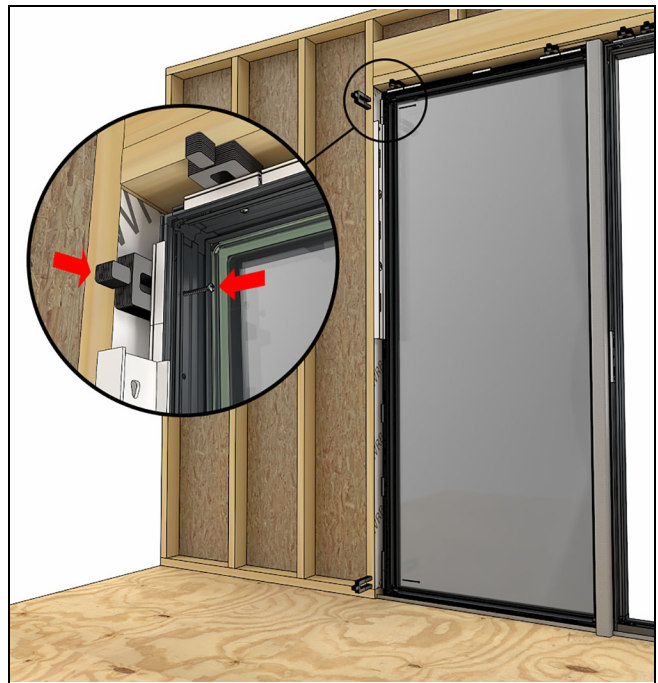

Figure 240

21. Using the hardware holes as a guide, drill into the steel with the appropriate bit. Use the table in step 12 on page 62 for reference. See Figure 241.

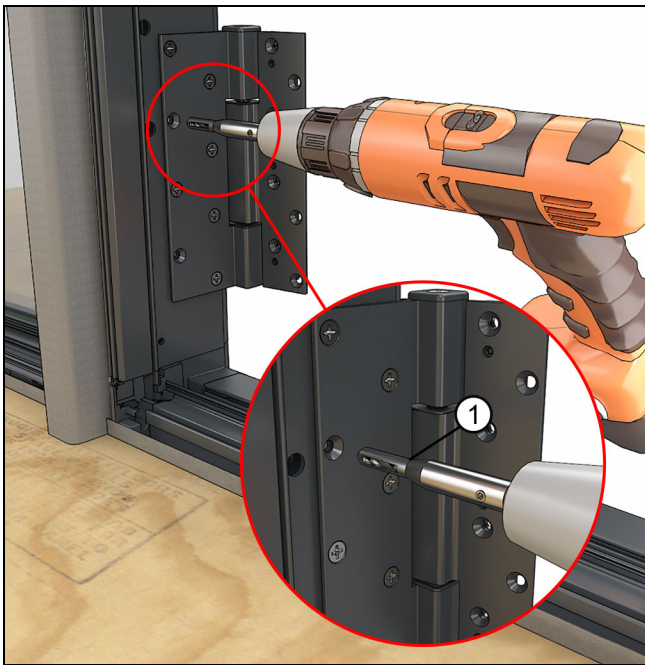

Figure 241 Pre-drill Hinges

1	#2 centering bit
---	------------------

22. Complete shimming and fastening around the entire perimeter using the installation holes and/or hardware holes. See [Figure 242](#), [Figure 243](#), [Figure 244](#), and [Figure 245](#).

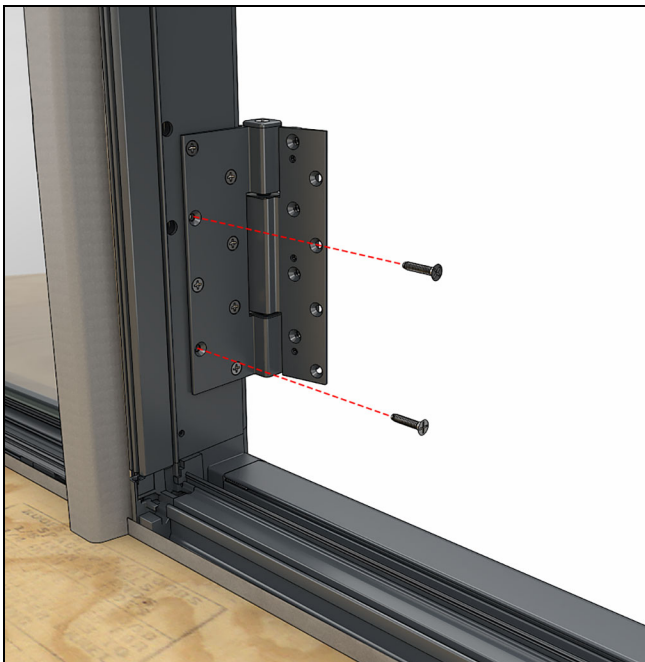

Figure 242 Hinges

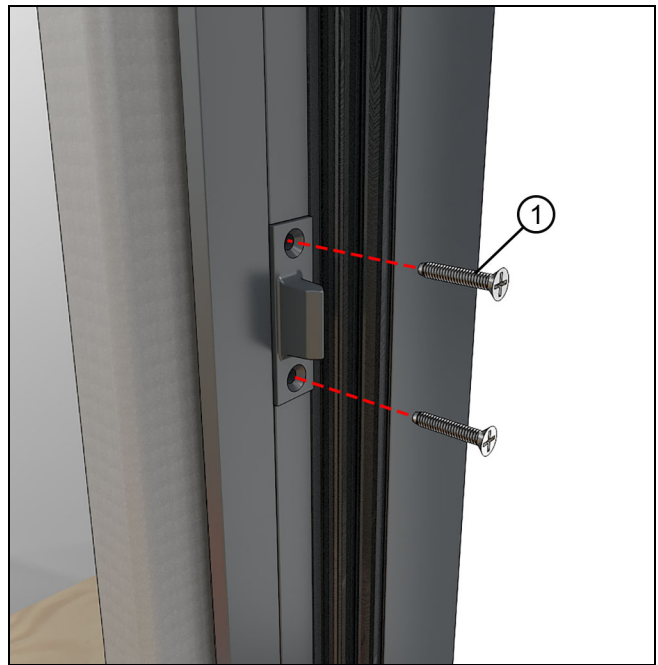

Figure 243 Panel alignment bolts

1	#10 x 7/8" trilobular screw
---	-----------------------------

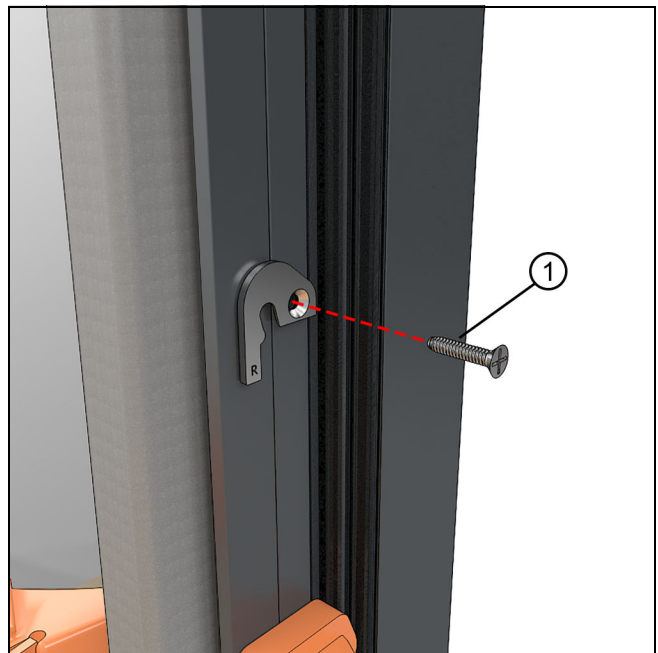

Figure 244 Stationary brackets

1	#10 x 7/8" trilobular screw
---	-----------------------------



Figure 245 Strikes

1	#8 x 7/8" trilobular screws
---	-----------------------------

NOTE: Dow 995 Structural sealant is included in the job box and but isn't used in a structural manner when sealing the mull. Other appropriate sealants such as CSL 343 may be used starting on the [next step](#) through [step 26](#) on [page 67](#).

23. Using a screen spline roller or similar tool, apply frame kerf weather strip in the frame kerf along the mull. See [Figure 154](#).



Figure 246

24. Apply three beads of sealant over the mull fillers—one on each side (between the fillers and frame) and one in the middle. See [Figure 247](#).

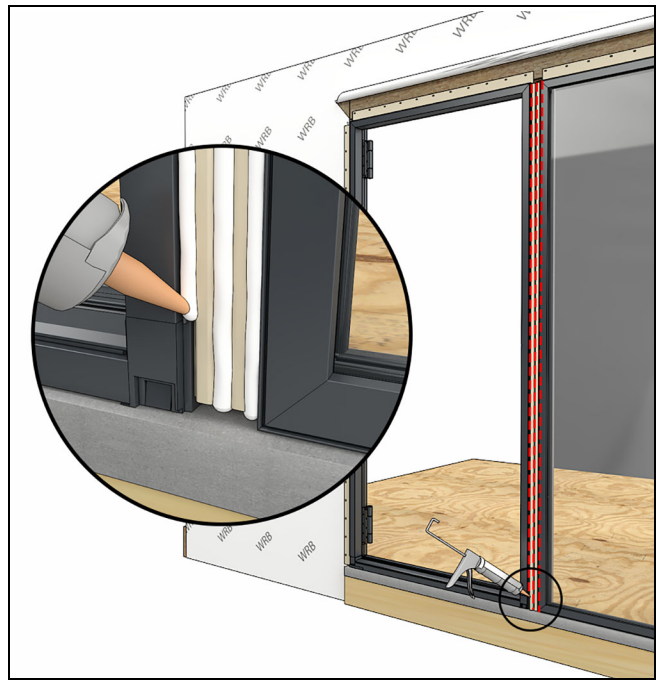

Figure 247

25. Apply sealant on the ends of the mull filler and over the ends of the tube steel as shown in [Figure 248](#).

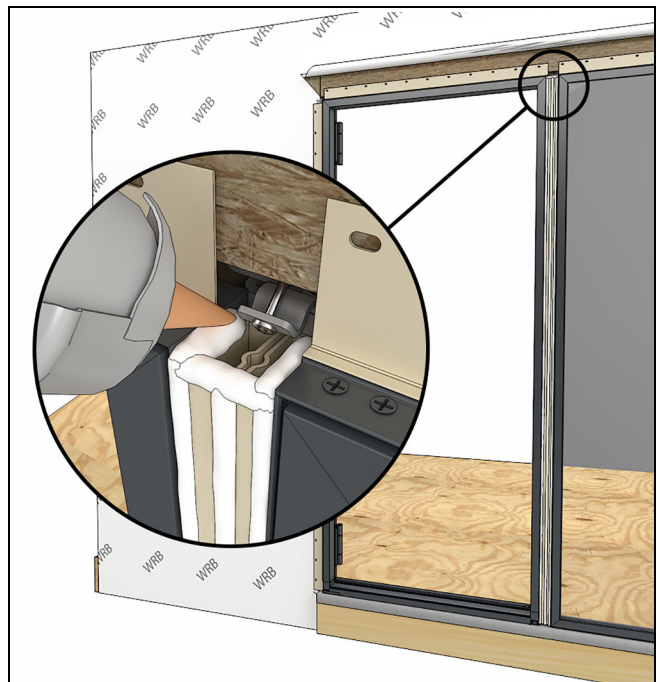

Figure 248

26. Seat foam blocks in the sealant at the head jamb and sill at the ends of the mull filler. See [Figure 249](#), [Figure 250](#), and [Figure 251](#).

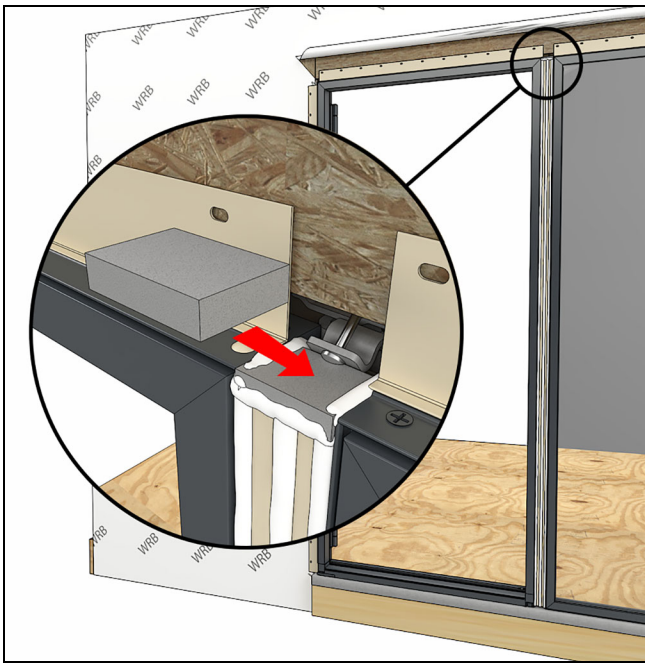

Figure 249

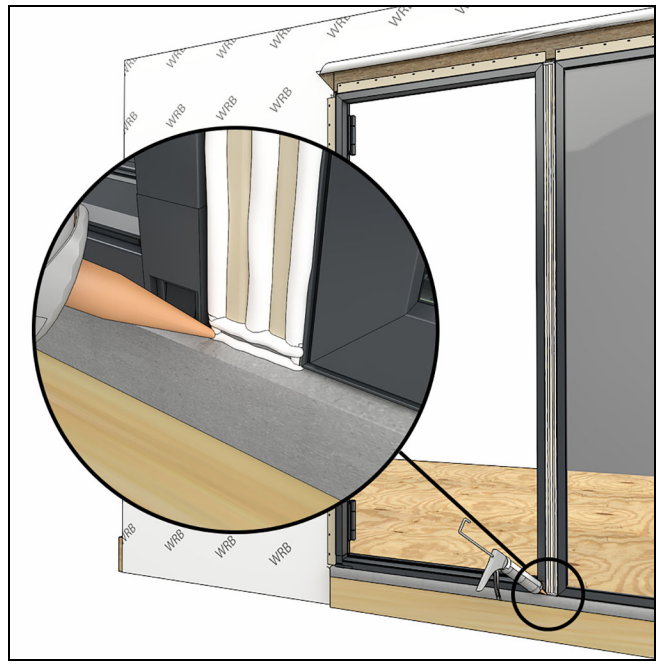

Figure 251

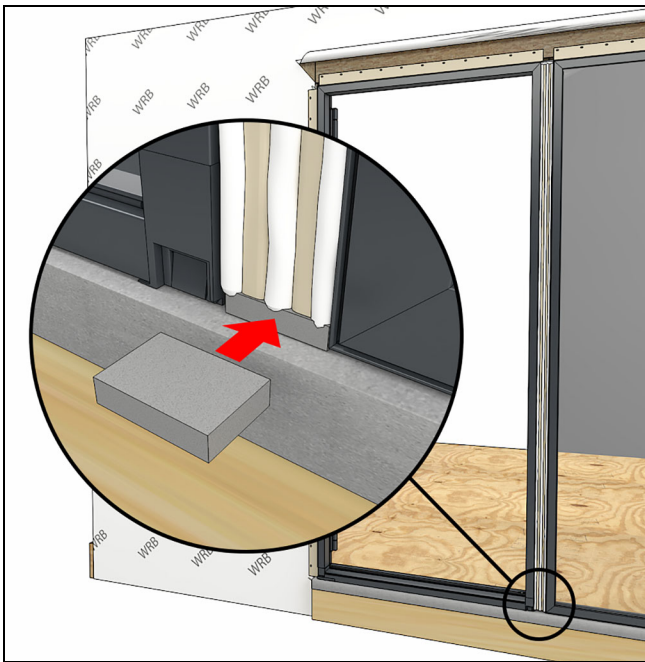

Figure 250



Hint

In some cases you may need to cut the foam block in half and insert into the end of the mull filler prior to installing the filler on the jambs.

27. Install the exterior mull cap. Seat in place with a rubber mallet. [See Figure 252.](#)

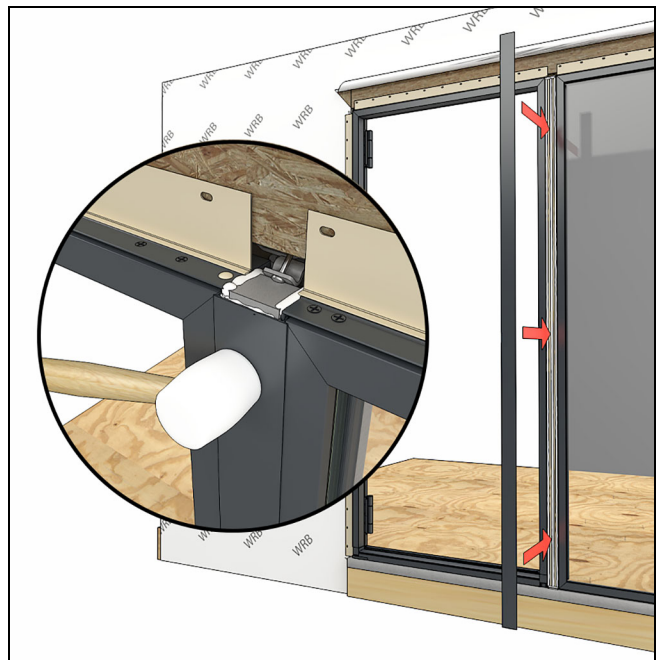

Figure 252



Hint

Clean any excess sealant off the frame at this time.

28. Install the interior mull cap. Seat with a rubber mallet. [Figure 253](#) and [Figure 254](#).



Figure 253



Figure 254 Cover for 4" tube steel shown

Special Instructions for Operating Outswing Hinge Mulls

NOTE: When fastening the tube steel and installing/sealing the mull filler use these steps where referenced in the main instruction.

NOTE: On an Outswing hinge mull to hinge mull configuration, you will only use the aluminum mull fillers from one side. Remove and discard the mull filler from one side.

1. Fasten the tube steel to the aluminum mull filler blocks using the access holes on the mull filler blocks. Pre-drill with #23 drill bit and fasten with #8 x 1/2" trilobular screws. [See Figure 255](#), [Figure 256](#), and [Figure 257](#).

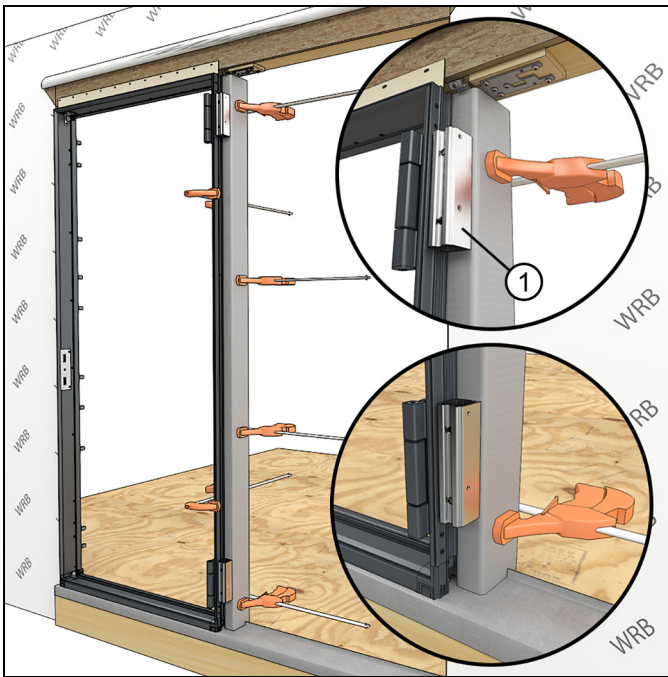

Figure 255 Clamp tube steel to frame against aluminum mull filler blocks.

1	Aluminum mull filler block
---	----------------------------

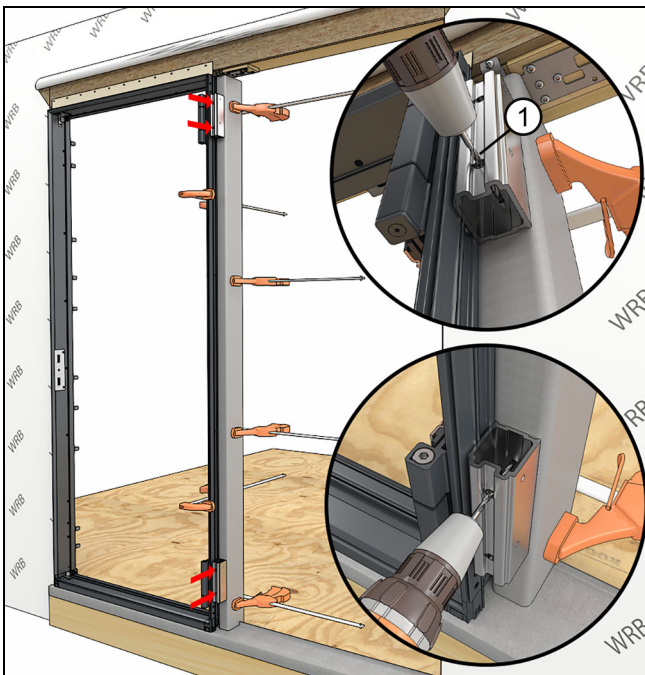

Figure 256 Predrill into tube steel

1	#23 drill bit
---	---------------

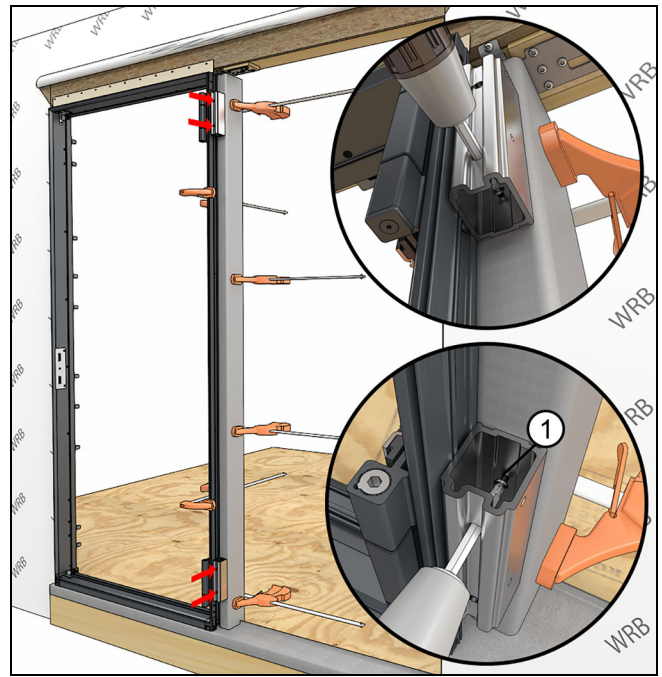

Figure 257

1	#8 x 1/2" trilobular screw
---	----------------------------

2. Fasten the frame to the tube steel through the hinges and installation holes.

3. Measure and cut the vinyl mull filler to length to fit between the aluminum mull fillers (within 1/8"). Additionally, cut blocks to fit at the top and bottom of the aluminum mull fillers (minus 3/8"). See [Figure 258](#).

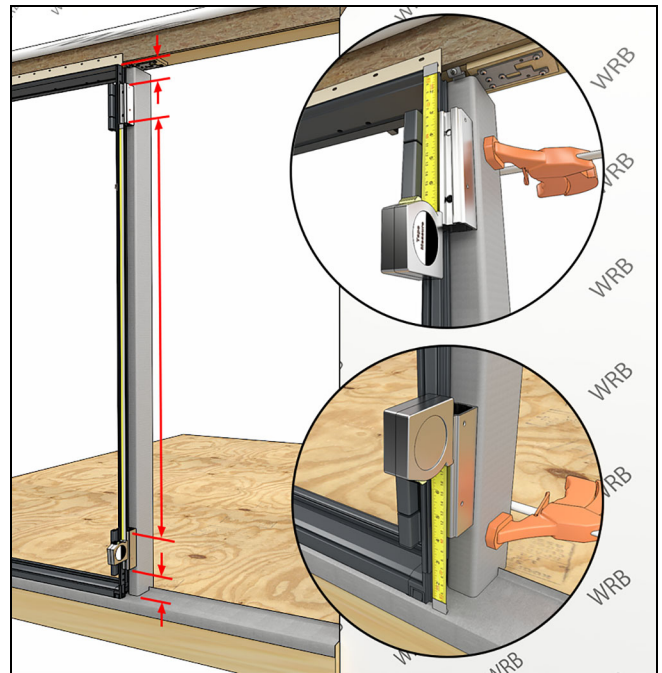

Figure 258

 **Tip**

Dry fit the vinyl mull fillers before proceeding. See [Figure 259](#).

See [Figure 261](#), [Figure 262](#), [Figure 263](#), [Figure 264](#), [Figure 265](#), and [Figure 266](#).

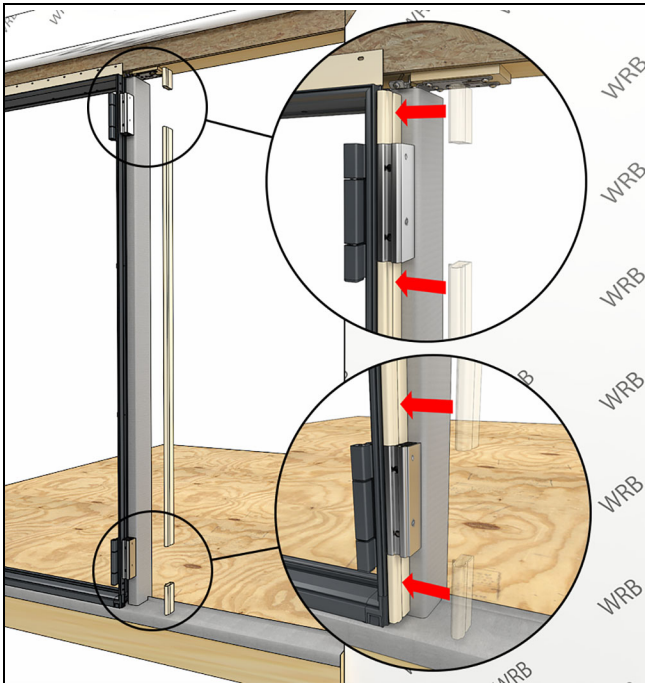

Figure 259 Dry-fit vinyl fillers on first unit.

4. Repeat previous steps for the next unit in the mull.

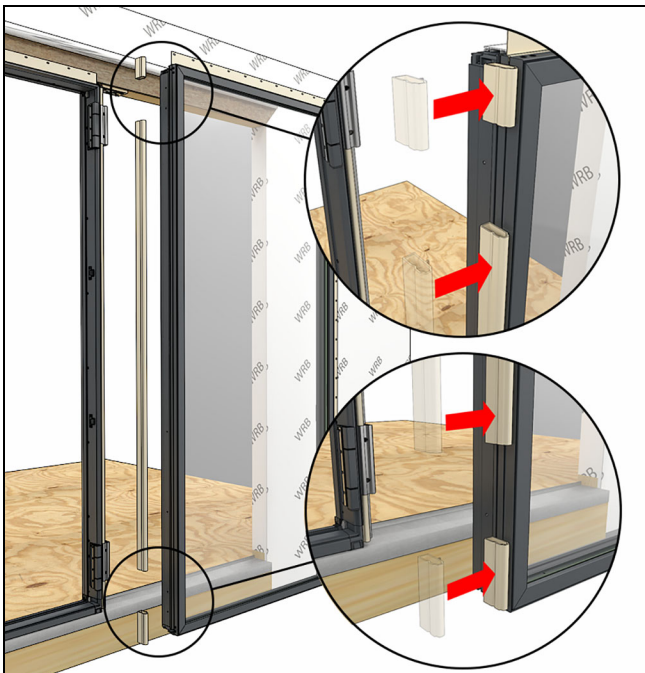

Figure 260 Dryfit fillers on second unit

5. Face seal the top surface of all mating mull filler blocks prior to installing the filler blocks onto the units.

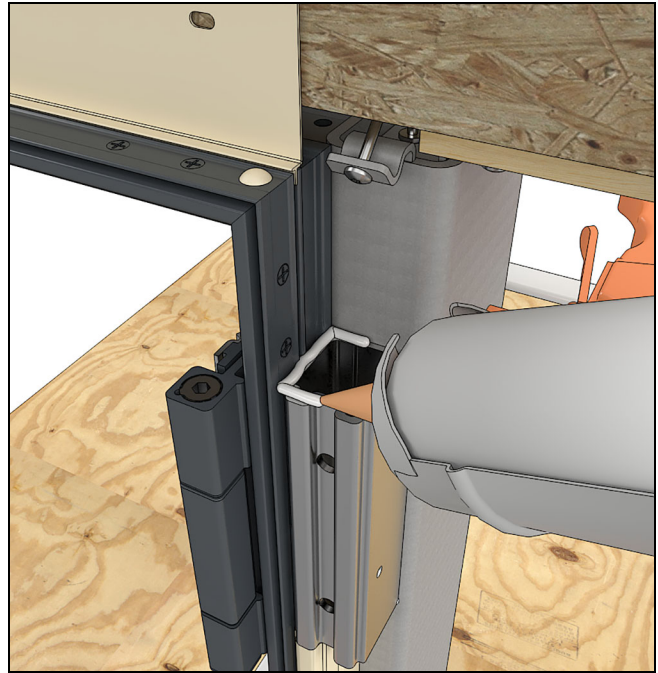

Figure 261

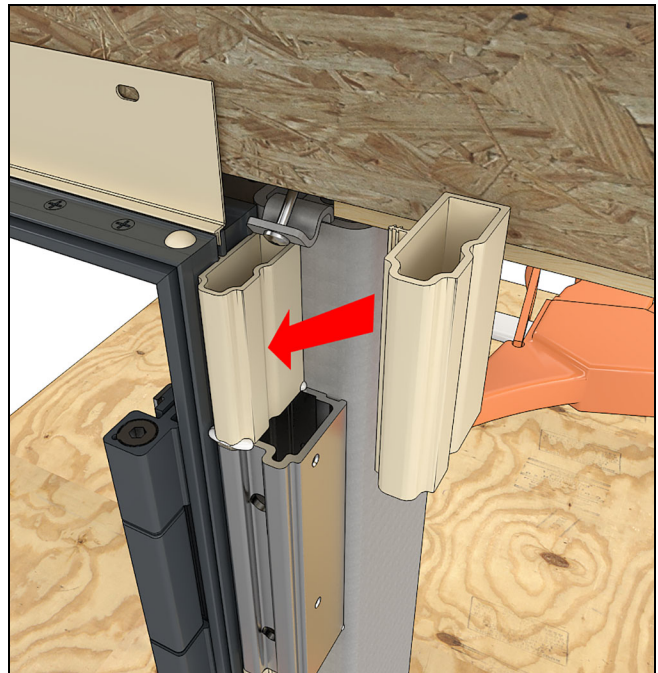

Figure 262

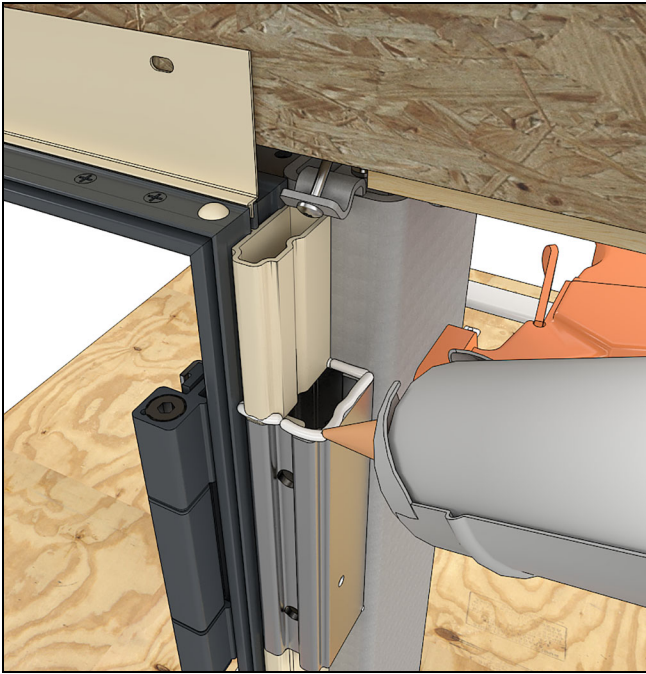

Figure 263

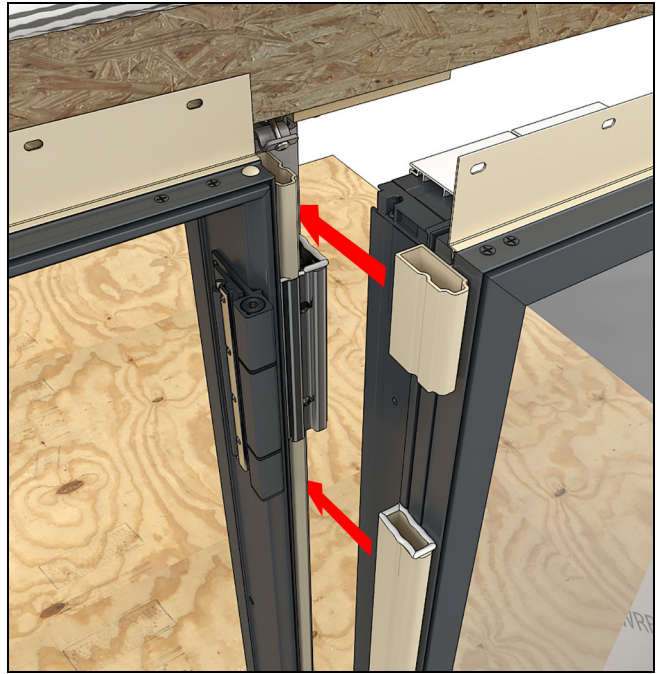

Figure 265



Figure 264

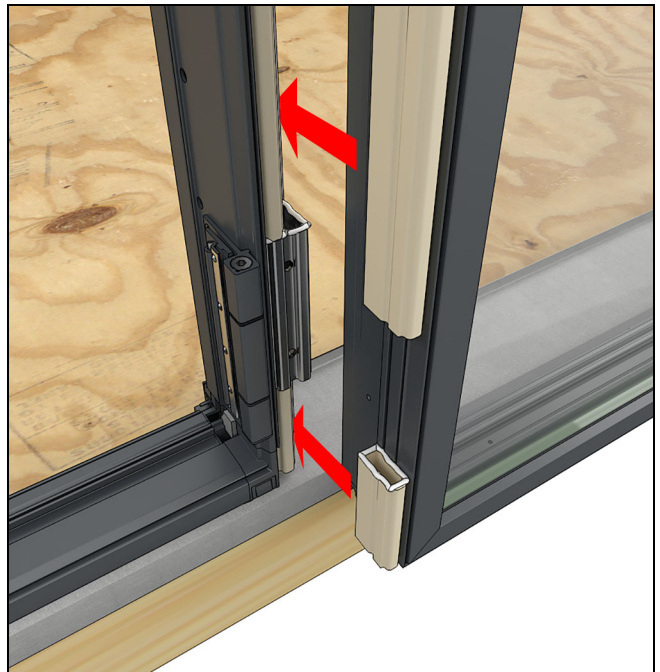

Figure 266

6. Install the second unit and fasten to the tube steel.

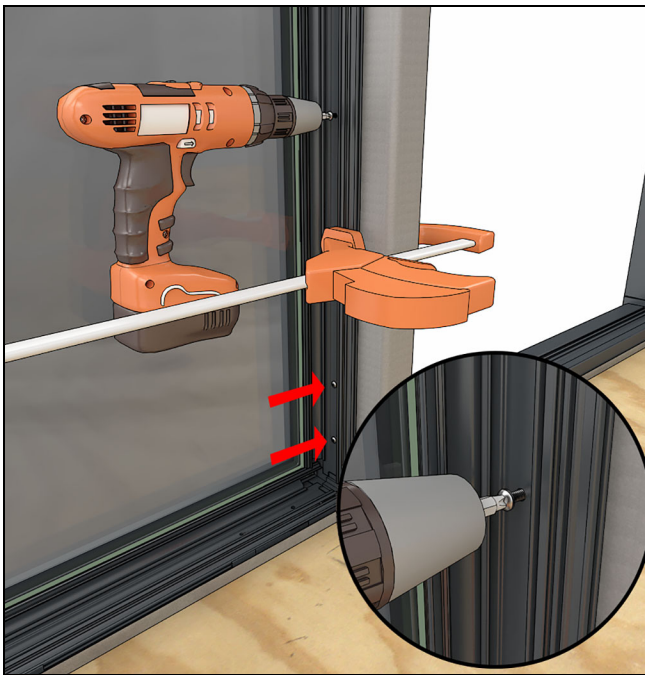

Figure 267



Tip

On a hinge to hinge mull, you will need to remove the aluminum mull fillers from the second unit. Reuse the screws to fasten the hinges to the aluminum mull filler on the first unit.

7. Follow the procedures starting with [step 24 on page 67](#) to seal the mull filler blocks.

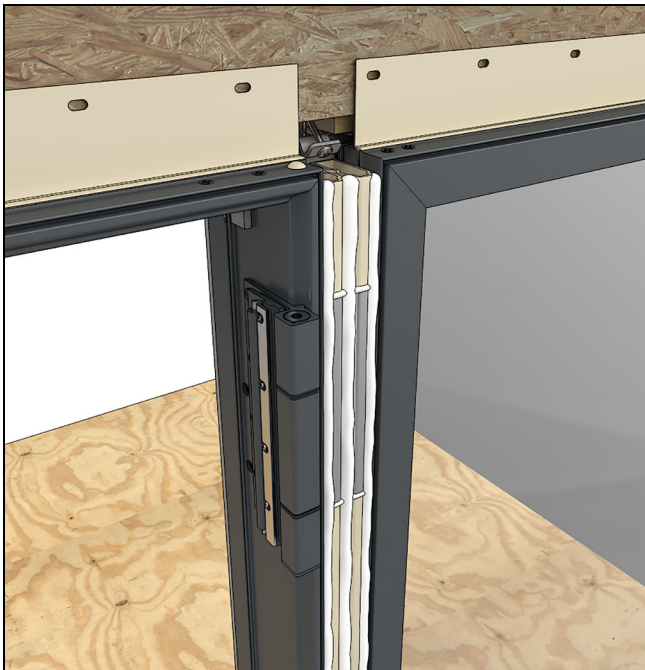

Figure 268 Show sealant with aluminum fillers and vinyl.

8. Install the mull covers following steps in the previous section.

Final Installation Details

Flashing Modern Window Installations

IMPORTANT

Nailing fin is not designed to be a weatherproof flashing.

IMPORTANT

Follow the flashing tape manufacturer's recommended instructions for attaching to the building material under the WRB. For example, priming wet or frozen wood, application temperature, etc.

1. If installed, seal behind the nailing fin at the jambs and head jamb. See [Figure 269](#) and [Figure 270](#).



Figure 269



Figure 270

2. On units that use nailing fin, apply a 2" x 4" strip of flashing material at 45 degrees to the corner, bridging the gap between the nailing fin. Do this at all 4 corners. See [Figure 271](#).

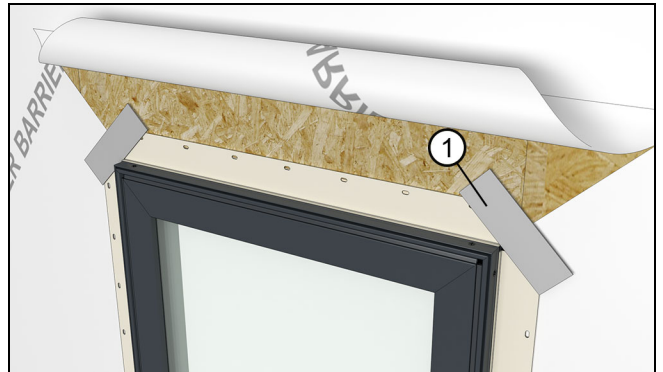

Figure 271

1	2" x 4" strip of flashing material
---	------------------------------------

3. Apply a bead of sealant between the gasket and the window exterior. Tool the sealant out. See [Figure 272](#).

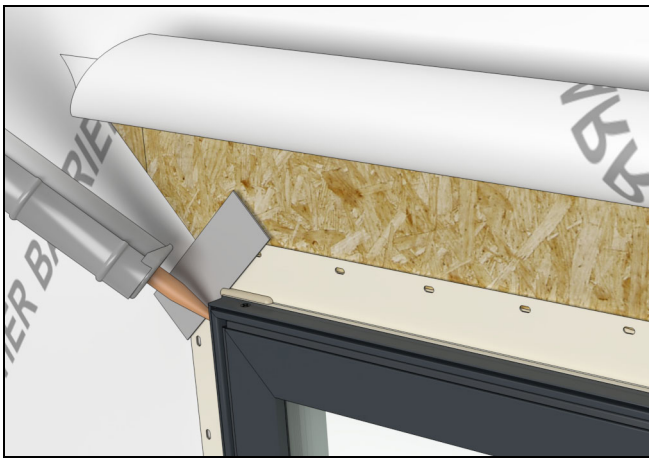

Figure 272

4. Install a rigid head flash. Apply sealant to all surfaces that will come in contact with the flashing. Flashing should extend past the window frame by at least 1/8" (3) on each side. See Figure 273.

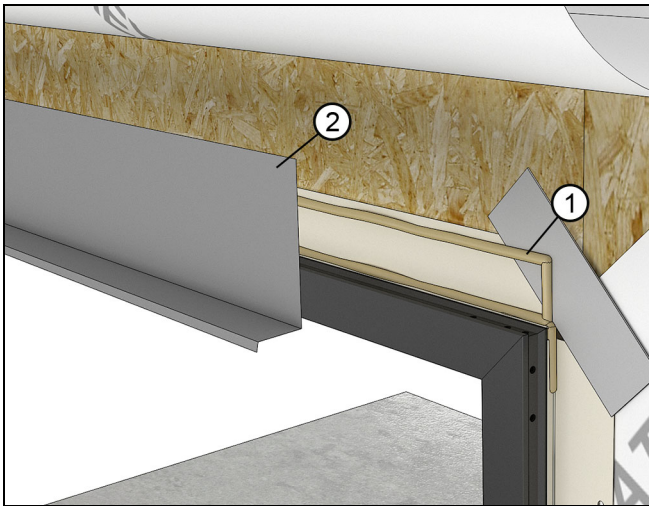

Figure 273

1	Sealant
2	Rigid head flash

5. **OPTIONAL SKIRT:** Install an optional "skirt" in applications with exposure to wind driven rain/climate. Use flashing material or a 12" (305) strip of WRB and attach to the sill of the window with seam seal tape or flashing tape. See Figure 274.

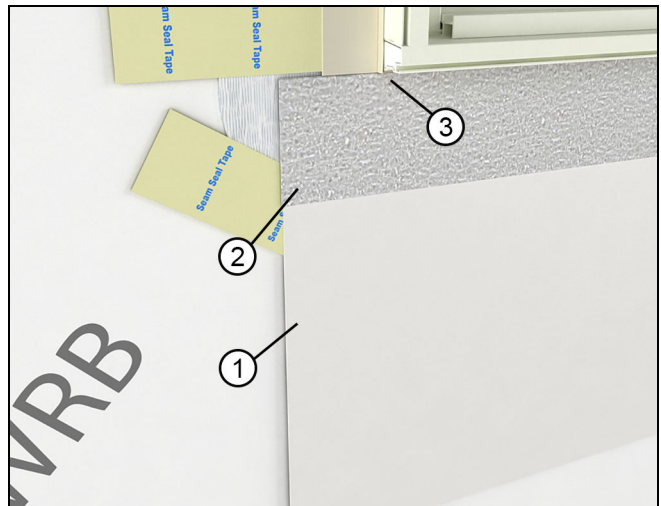

Figure 274

1	Skirt (WRB material or other)
2	Adhesive tape
3	Attached to sill of window

6. Lap vertical strips of adhesive flashing tape onto the window and out over the WRB. Make small diagonal cuts at the head jamb as in Figure 275 to allow the membrane to fold back onto the exterior and frame.

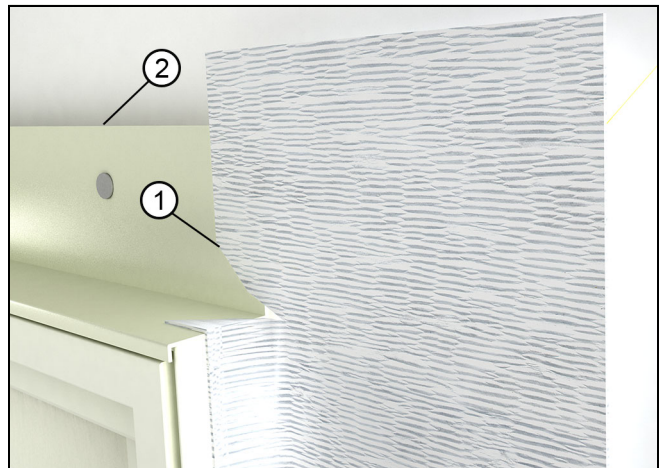

Figure 275

1	Diagonal cut in flashing
2	Rigid head flash

7. Install another layer of adhesive membrane lapping onto the rigid head flash of the window and over the sheathing. The membrane flashing at the head jamb should extend and cover the flashing previously installed at the jambs. Make relief cuts and fold down so that it wraps around the jamb. See Figure 276 and Figure 277.

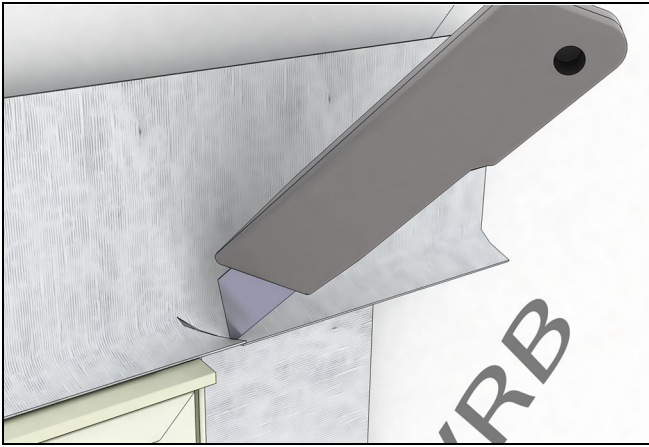

Figure 276

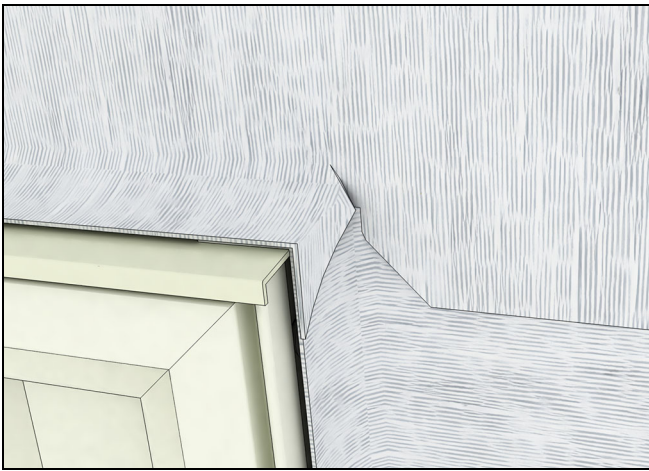

Figure 277

8. Tape the top edge of the head jamb flashing with seam seal tape. [See Figure 278.](#)



Figure 278

9. Seal the ends of the rigid head flash by injecting sealant at each end. [See Figure 279.](#)

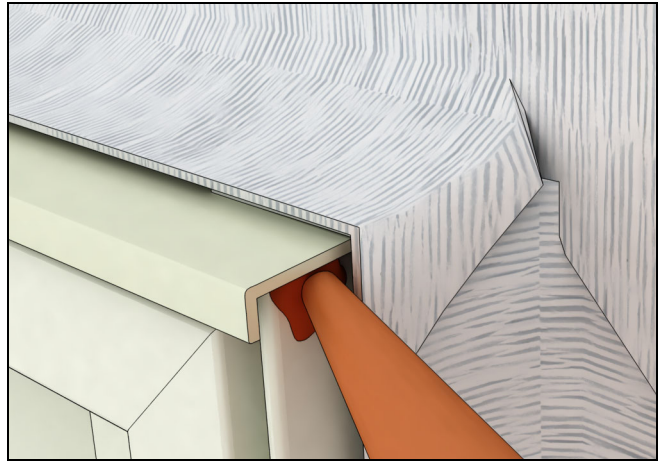

Figure 279

10. Fold the head jamb WRB down over the head jamb flashing. Apply seam seal tape over the diagonal cut in the WRB. Make sure the seam seal laps onto the window. Tape any seams and fasteners directly above the unit with seam seal tape. [See Figure 280.](#)

NOTE: This does not apply to self adhered WRB.

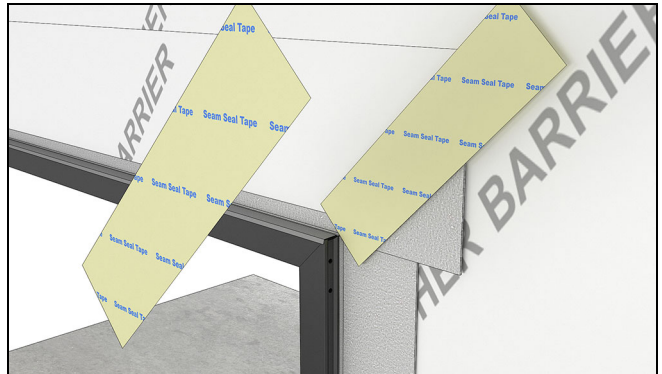

Figure 280