

ULTIMATE WOOD DOUBLE HUNG ULTIMATE WOOD DOUBLE HUNG INSERT

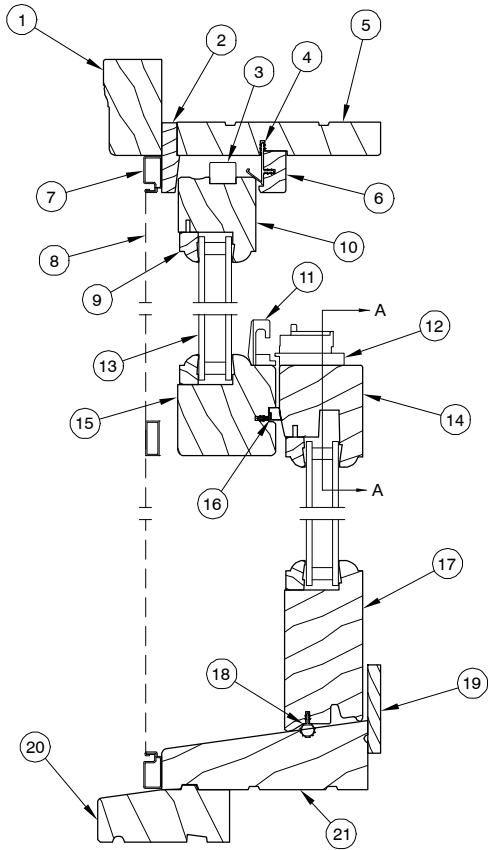
Table of Contents

	PAGE
History	2
Ultimate Wood Double Hung and Single Hung	
Part Identification – Ultimate Wood Double Hung	3
Part Identification – Ultimate Wood Single Hung	4
Part Identification – Ultimate Wood Double Hung Transom	5
Part Identification – Ultimate Wood Double Hung Picture 1 5/8 inch Sash	6
Part Identification – Ultimate Wood Double Hung Picture 2 inch Sash	7
Ultimate Wood Double Hung Insert	
Part Identification – Ultimate Wood Double Hung and Single Hung Insert	8
Part Identification – Ultimate Wood Double Hung Insert Transom	9
Part Identification – Ultimate Wood Double Hung Insert Picture	10
Parts – Ultimate Wood Double/Single Hung, Insert Units	
Hardware Parts – Ultimate Wood Double Hung/ Single Hung	11
Hardware Parts – Ultimate Wood Double Hung and Single Hung Insert	15
Balances – Ultimate Wood Double Hung and Single Hung	16
Jamb Carriers – Ultimate Wood Double Hung and Single Hung	18
Jamb Carrier Hardware Assemblies – Ultimate Wood Double Hung/Single Hung	19
Balances and Jamb Carrier Hardware Assemblies–Ultimate Wood Double Hung and Single Hung Insert	21
Wood Parts – Ultimate Wood Double Hung/Single Hung	22
Wood Parts – Ultimate Wood Double Hung Insert	23
Aluminum and Vinyl Parts – Ultimate Wood Double Hung/Single Hung and Insert	24
Weather Strip – Ultimate Wood Double Hung/Single Hung	25
Sash Replacement – Ultimate Wood Double Hung/Single Hung, Picture, Transom	26
Screens – Ultimate Wood Double Hung/Single Hung/Insert	27
Screens – Half Screen– Ultimate Wood Double Hung/Single Hung/Insert	28
Screen Parts – Ultimate Wood Double Hung/Single Hung	29
Screens – Optional Magnum– Ultimate Wood Double Hung/Single Hung	30
Screens Parts – Optional Magnum – Ultimate Wood Double Hung/Single Hung	31
Energy Panels and Parts – Ultimate Wood Double Hung	32
Combinations – Ultimate Wood Double Hung	33
Combination Parts – Ultimate Wood Double Hung	34
Mulling Kits and Parts – Ultimate Wood Double Hung Insert/Single Hung Insert	35
Exterior Trim Kits – Ultimate Wood Double Hung Insert/Single Hung Insert	36
Combination Parts – Limited Availability (LA) Pre 4/2001	37

ATTENTION:

- Specification and technical data are subject to change without notice.
- Numbers listed in parentheses () are metric equivalents in millimeters rounded to the nearest whole number.

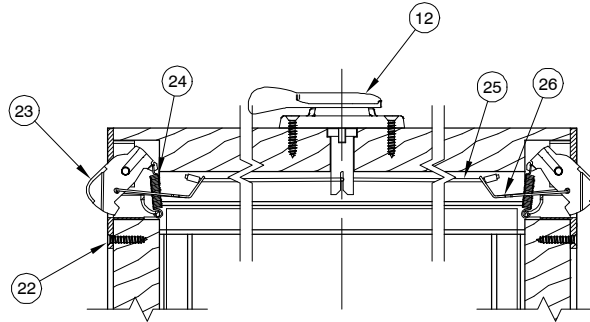
PRODUCED	UNIT TYPE	FEATURES OR CHANGES	STATUS
2001	Ultimate Wood Double Hung/Single Hung	1/15/01 Introduced (regionally to complement below) featuring tilt latch system operated at center sash lock on bottom operating sash. (DH/SH) Top operating sash released at top rail by two tilt latches. (DH) Rough opening heights are 1/16" less than Wood E-Z Tilt rough opening heights. A 1 5/8" sash with SG or .700" IG will be available in operating DH or SH units, limited picture sizes, all transom sizes and ADL units. A 2" sash with 1" IG will be available in any one-lite picture unit. A unique subsill design facilitates easy-to-mull assemblies.	Present
2003	Ultimate Wood Double Hung	3/31/03 Satin Taupe (TP) hardware replaces bronze as standard.	Present
2003	Ultimate Wood Double Hung Insert, Picture 1 5/8 inch Sash, Picture 2 inch Sash, Transom	10/03 -Wood frame and sash are designed to be installed into pre-existing window frame.	Current
2004	Ultimate Wood Double Hung	1/04 Added Oil Rubbed Bronze and Satin Chrome to available hardware finishes	Present
2004	Ultimate Wood Double Hung	6/14/04 Satin Nickel hardware introduced as a standard option. Polished Chrome hardware discontinued.	Present
2006	Ultimate Wood Double Hung	3/23/06 Both UWDH and UWDHM now use same jamb blind stop (W8950).	Present
2007	Ultimate Wood Double Hung	10/22/2007 Created new balance tube hanger. S-hooks are no longer used.	Present
2008	Ultimate Wood Double Hung	6/02/2008 Introduced charcoal colored high transparency screen mesh (CH HI-TRAN) as an option on all window and door products (including combinations).	Present
2011	All	04/25/2011 Added LoE-180™ as a standard option for all products. White painted interior finish option introduced for all products.	Present
2012	Ultimate Wood Double Hung	02-27-2012 Introduced taller sizes CN40 and 42 to the product line. Introduced the option magnum screen. 10/29/2012 Interior Square Sticking/Glazing Bead option introduced.	Present
2012	Ultimate Wood Double Hung	12-17-2012 Introduced Clear interior finish option on all products.	Present
2013	Ultimate Wood Double Hung	04/29/2013 Introduced interior stain options. Stain colors are Wheat, Honey, Leather, Hazelnut, Cabernet and Espresso.	Present
2017	All	10/30/2017 Discontinued EP colors with exception of Stone White and Bronze	Present
2020	All	04/27/2020 Discontinued (Disc-NA) combination colors with exception of Stone White and Bronze	Present



**Head Jamb
and Sill Detail**

Ultimate Wood Double Hung

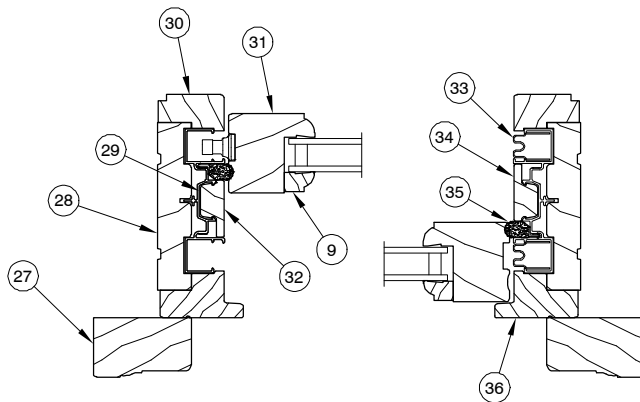
- | | |
|-------------------------------------|------------------------------------|
| 1. Top Brick Mould Casing, W1047 | 19. Sill Liner, W2146 |
| 2. Top Blind Stop, W2125 | 20. Subsill, W2134 |
| 3. Tilt Latch | 21. Sill |
| 4. Parting Stop Weather Strip, V945 | 22. End Plate |
| 5. Head Jamb | 23. Locking Blade |
| 6. Parting Stop, W2530 | 24. Extension Spring |
| 7. Screen Frame | 25. Operation Cord |
| 8. Screen | 26. Pull Yoke |
| 9. Glazing Bead | 27. Side Brick Mould Casing, W1047 |
| 10. Top Rail | 28. Side Jamb |
| 11. Sash Keeper | 29. Vinyl Jamb Carrier, V100 |
| 12. Sash Lock | 30. Jamb Liner |
| 13. Insulated Glass | 31. Stile |
| 14. Bottom Check Rail | 32. Top Wood Jamb Filler |
| 15. Top Check Rail | 33. Sash Balance Tube |
| 16. Check Rail Weather Strip, V031 | 34. Bottom Wood Jamb Filler |
| 17. Bottom Rail | 35. Frame Weather Strip, V2838 |
| 18. Bottom Rail Weather Strip, V147 | 36. Jamb Blind Stop, W8950 |



Section A-A

Bottom Sash

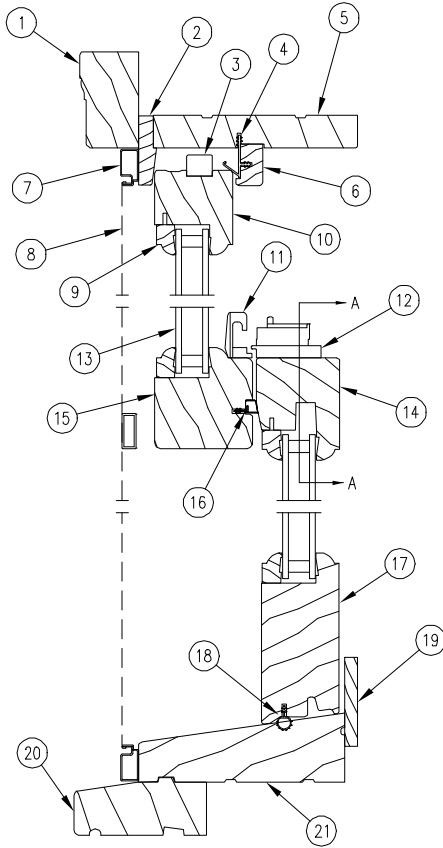
Top Sash



Jamb Detail

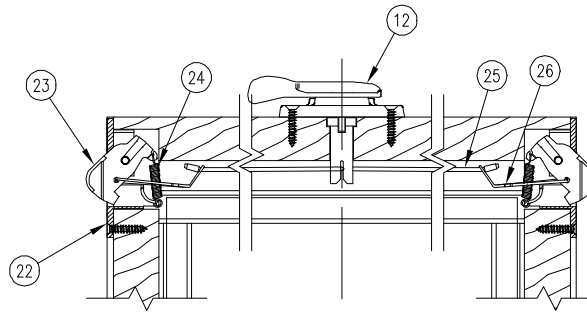
NOTE: Not to scale; specifications subject to change without notice.

Ultimate Wood Single Hung



**Head Jamb
and Sill Detail**

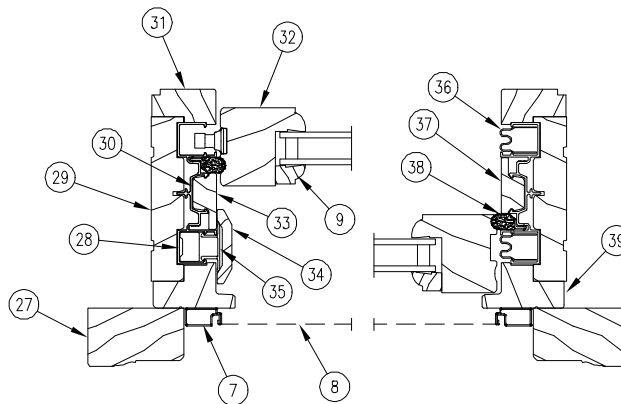
- | | |
|-------------------------------------|------------------------------------|
| 1. Top Brick Mould Casing, W1047 | 21. Sill |
| 2. Top Blind Stop, W2125 | 22. End Plate |
| 3. Tilt Latch | 23. Locking Blade |
| 4. Parting Stop Weather Strip, V945 | 24. Extension Spring |
| 5. Head Jamb | 25. Operation Cord |
| 6. Parting Stop, W2530 | 26. Pull Yoke |
| 7. Screen Frame | 27. Side Brick Mould Casing, W1047 |
| 8. Screen Mesh | 28. Sash Stop |
| 9. Glazing Bead | 29. Side Jamb |
| 10. Top Rail | 30. Vinyl Jamb Carrier, V100 |
| 11. Sash Keeper | 31. Jamb Liner, W2127 |
| 12. Sash Lock | 32. Stile |
| 13. Insulated Glass | 33. Top Wood Jamb Filler |
| 14. Bottom Check Rail | 34. Jamb Carrier Filler Cap |
| 15. Top Check Rail | 35. Aluminum Filler |
| 16. Check Rail Weather Strip, V031 | 36. Sash Balance Tube |
| 17. Bottom Rail | 37. Bottom Wood Jamb Filler, W2018 |
| 18. Bottom Rail Weather Strip, V147 | 38. Frame Weather Strip, V2838 |
| 19. Sill Liner, W2146 | 39. Jamb Blind Stop, W8950 |
| 20. Subsill, W2134 | |



Section A-A

Bottom Sash

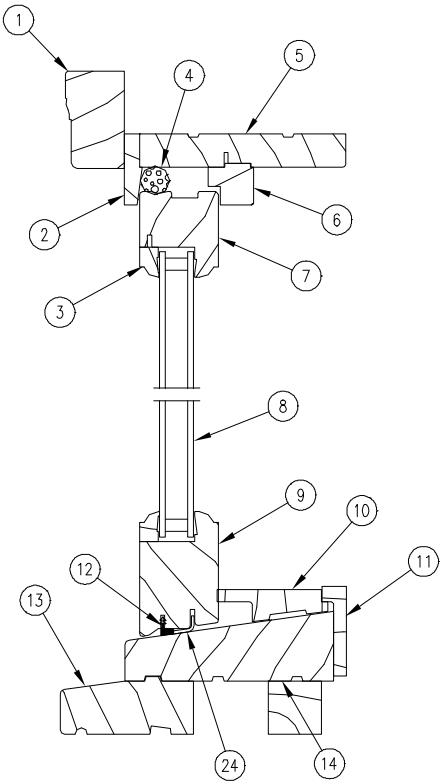
Top Sash



Jamb Detail

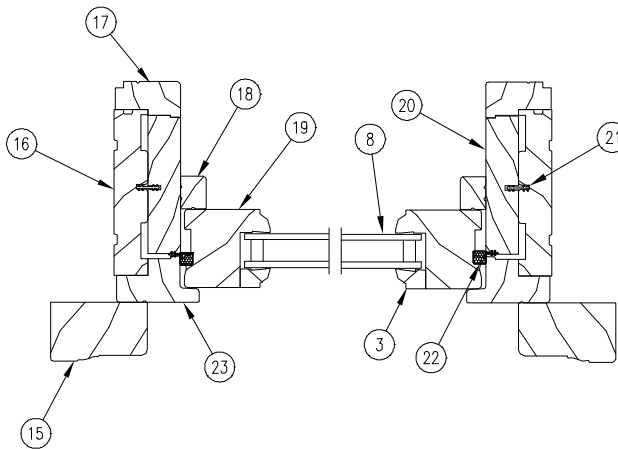
NOTE: Not to scale; specifications subject to change without notice.

Ultimate Wood Double Hung Transom



- 1. Top Brick Mould Casing, W1047
- 2. Top Blind Stop, W2125
- 3. Sash Glazing Bead
- 4. Foam Backer Rod
- 5. Head Jamb
- 6. Head Jamb Stop, W7136
- 7. Top Rail
- 8. Insulated Glass
- 9. Bottom Rail
- 10. Sill Filler, W7122
- 11. Sill Liner, W2179
- 12. Bottom Rail Weather Strip, V031
- 13. Subsill, W2134
- 14. Sill
- 15. Side Brick Mould Casing, W1047
- 16. Jamb
- 17. Interior Jamb Liner, W2127
- 18. Interior Stop, W7134
- 19. Stile
- 20. Jamb Filler, W7126
- 21. Connecting Barb
- 22. Jamb Weather Strip, V031
- 23. Exterior Blind Stop, W8950

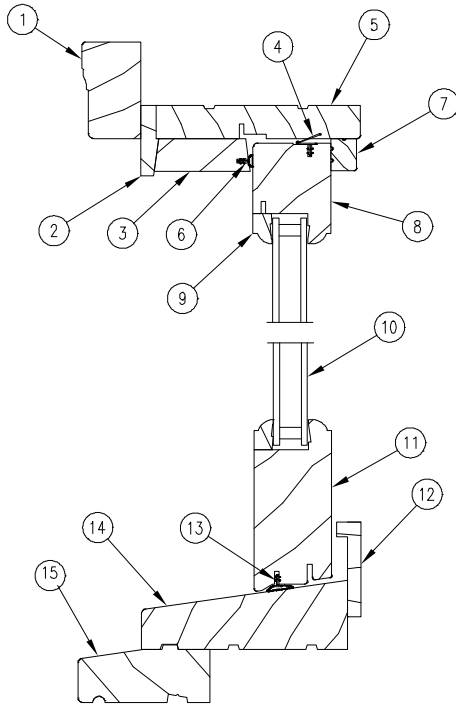
**Head Jamb
and Sill Detail**



Jamb Detail

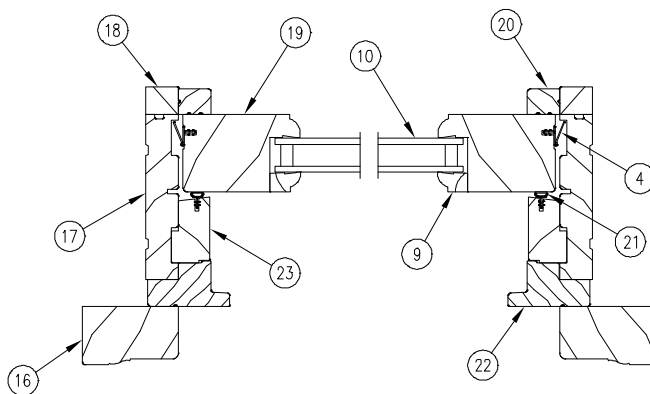
NOTE: Not to scale; specifications subject to change without notice.

Ultimate Wood Double Hung Picture 1 5/8 inch Sash



1. Top Brick Mould Casing
2. Top Blind Stop, W2125
3. Exterior Head Jamb Filler, W2175
4. Vinyl Retainer, V130
5. Head Jamb, W2173
6. Top Rail Weather Strip, V147
7. Interior Stop, W7134
8. Top Rail
9. Glazing Bead
10. Insulated Glass
11. Bottom Rail
12. Sill Liner, W2179
13. Bottom Rail Weather Strip, V147
14. Sill
15. Subsill, W2134

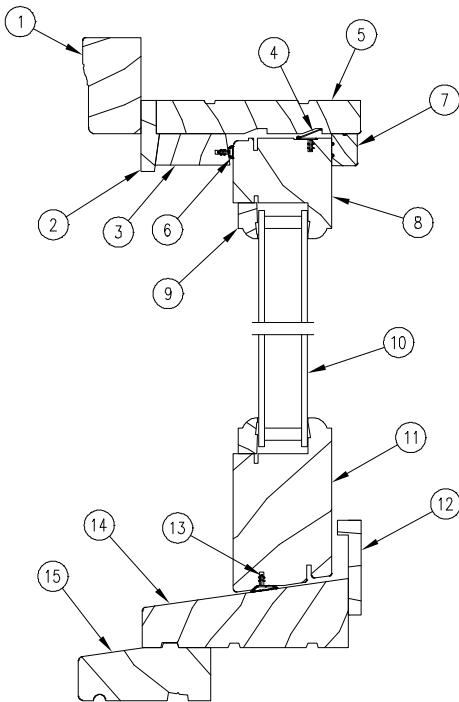
**Head Jamb
and Sill Detail**



Jamb Detail

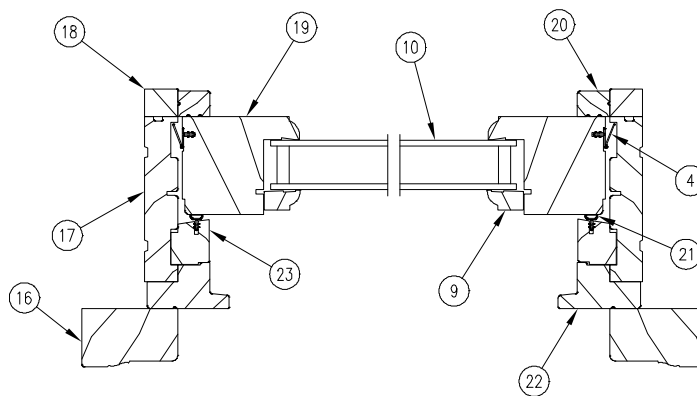
NOTE: Not to scale; specifications subject to change without notice.

Ultimate Wood Double Hung Picture 2 inch Sash



1. Top Brick Mould Casing, W1047
2. Top Blind Stop, W2125
3. Exterior Head Jamb Filler, W7128
4. Vinyl Retainer, V130
5. Head Jamb
6. Top Rail Weather Strip, V147
7. Interior Stop, W7134
8. Top Rail
9. Glazing Bead
10. Insulated Glass
11. Bottom Rail
12. Sill Liner, W2179
13. Bottom Rail Weather Strip, V147
14. Sill
15. Subsill, W2134
16. Side Brick Mould Casing, W1047
17. Jamb
18. Jamb Liner, W2143
19. Stile
20. Interior Stop, W7134
21. Sash Weather Strip, W147
22. Exterior Blind Stop, W8950
23. Exterior Filler, W7131

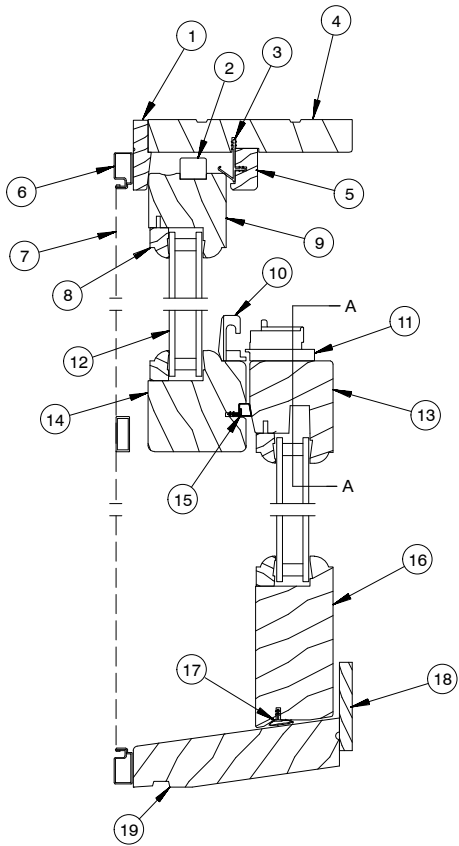
**Head Jamb
and Sill Detail**



Jamb Detail

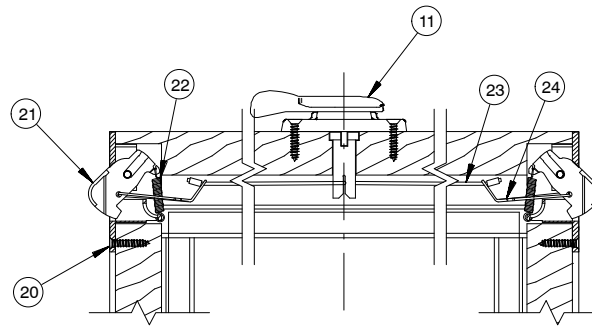
NOTE: Not to scale; specifications subject to change without notice.

Ultimate Wood Double Hung/Single Hung Insert



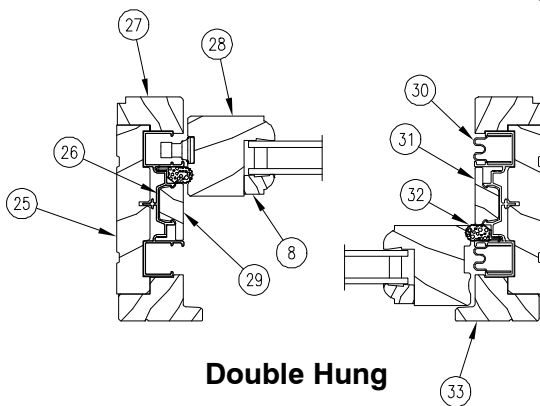
Head Jamb and Sill Detail

- | | |
|---------------------------------|-----------------------------|
| 1. Top Blind Stop | 19. Sill Liner |
| 2. Tilt Latch | 20. Sill |
| 3. Parting Stop Weatherstrip | 21. End Plate |
| 4. Head Jamb | 22. Locking Blade |
| 5. Parting Stop | 23. Extension Spring |
| 6. Screen Frame | 24. Operation Cord |
| 7. Screen Mesh | 25. Pull Yoke |
| 8. Glazing Bead | 26. Jamb |
| 9. Top Rail | 27. Vinyl Jamb Carrier |
| 10. Sash Keeper | 28. Jamb Liner |
| 11. Sash Lock | 29. Stile |
| 12. Insulated Glass | 30. Top Wood Jamb Filler |
| 13. Bottom Check Rail | 31. Sash Balance Tube |
| 14. Top Check Rail | 32. Bottom Wood Jamb Filler |
| 15. Top Check Rail Weatherstrip | 33. Frame Weatherstrip |
| 16. Bottom Rail | 34. Jamb Blind Stop |
| 17. Bottom Rail Weatherstrip | 35. Jamb Carrier Filler |

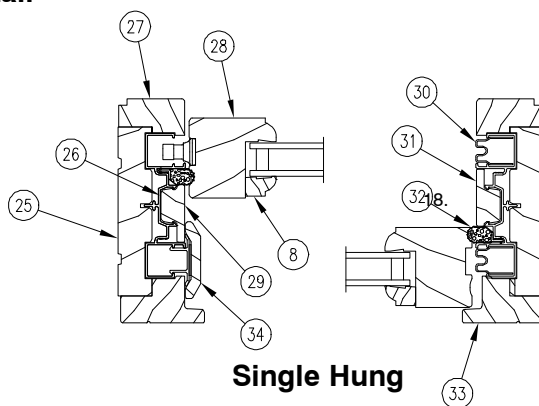


Section A-A

Jamb Detail



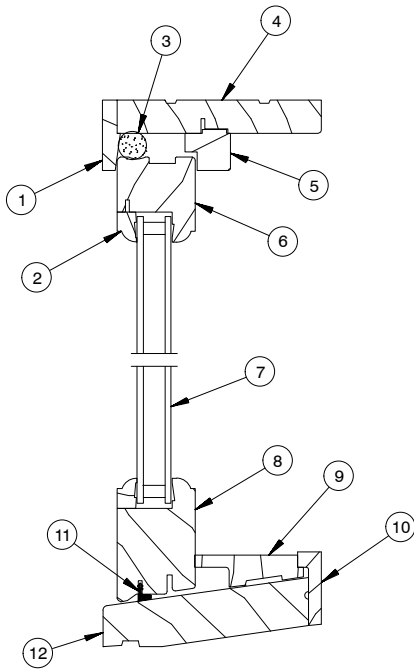
Double Hung



Single Hung

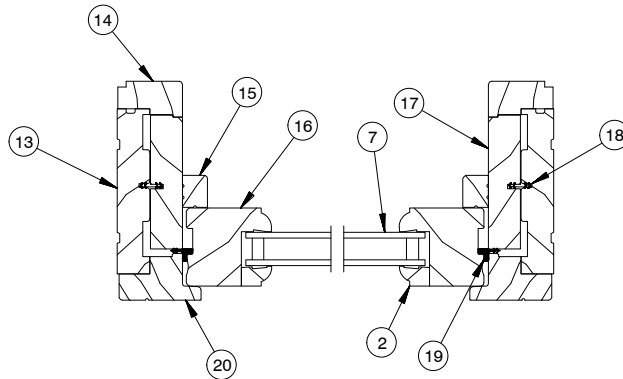
NOTE: Not to scale; specifications subject to change without notice.

Ultimate Wood Double Hung Insert Transom



- 1. Top Blind Stop
- 2. Sash Glazing Bead
- 3. Foam Backer Rod
- 4. Head Jamb
- 5. Head Jamb Stop
- 6. Top Rail
- 7. Insulated Glass
- 8. Bottom Rail
- 9. Sill Filler
- 10. Sill Liner
- 11. Bottom Rail Weatherstrip
- 12. Sill

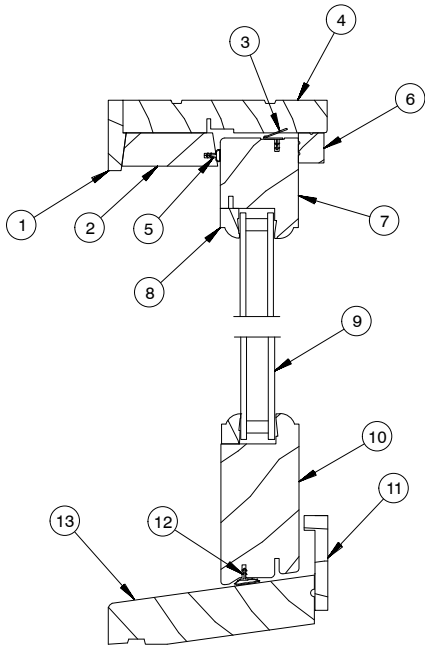
**Head Jamb
and Sill Detail**



Jamb Detail

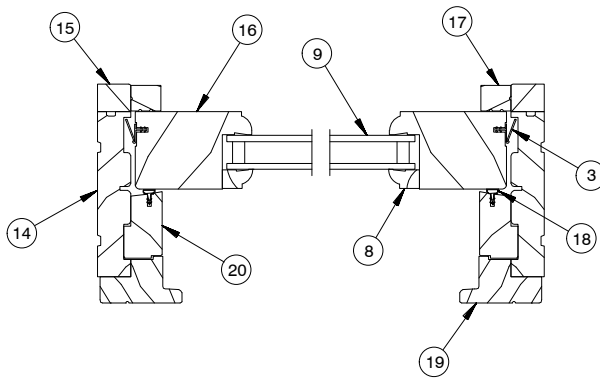
NOTE: Not to scale; specifications subject to change without notice.

Ultimate Wood Double Hung Insert Picture



- 1. Top Blind Stop
- 2. Exterior Head Jamb Filler
- 3. Vinyl Retainer
- 4. Head Jamb
- 5. Top Rail Weatherstrip
- 6. Interior Stop
- 7. Top Rail
- 8. Glazing Bead
- 9. Insulated Glass
- 10. Bottom Rail
- 11. Sill Liner
- 12. Bottom Rail Weatherstrip
- 13. Sill

**Head Jamb
and Sill Detail**



Jamb Detail

NOTE: Not to scale; specifications subject to change without notice.

When ordering parts specify:

1. original order number;
2. type of unit;
3. part number;
4. description.

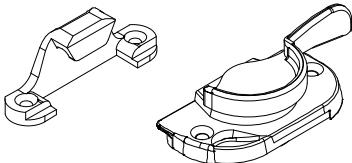
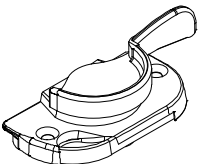
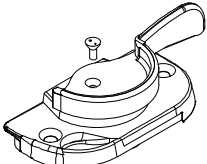
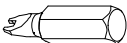
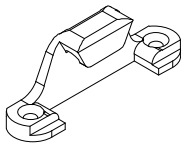
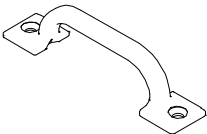
ILLUSTRATION NOT TO SCALE	DESCRIPTION	OPER./COLOR	PART NO.
	<p>Sash Lock and Keeper, Complete</p> <p><i>Includes:</i> 1 - Sash lock 1 - Keeper 4 - #7x7/8" Phillips flathead wood screws</p>	<p>Satin Taupe Bronze White</p>	<p>11869288 11869287 11869286</p>
	<p>Sash Lock</p> <p><i>Includes:</i> 1 - Sash lock 2 - #7x7/8" Phillips flathead wood screws</p>	<p>Satin Taupe Bronze White Brass Antique Brass Satin Chrome Satin Nickel Oil Rubbed Bronze Polished Chrome</p>	<p>10500669 10500668 10500662 10500783 10500789 10500784 10500788 10500787 10500785</p>
	<p>Custodial Sash Lock</p> <p><i>Includes:</i> 1 - Sash lock 2 - #7x7/8" Phillips flathead wood screws 1 - Tamper resistant screw</p>	<p>Satin Taupe Bronze White</p>	<p>10500544 10500545 10500546</p>
	<p>Tool Bit - Tampered Resistant Screw</p>		<p>10500543</p>
	<p>Keeper</p> <p><i>Includes:</i> 1 - Keeper 2 - #7x7/8" Phillips flathead wood screws</p>	<p>Satin Taupe Bronze White Brass Antique Brass Satin Chrome Satin Nickel Oil Rubbed Bronze Polished Chrome</p>	<p>10500676 10500674 10500670 10500793 10500799 10500794 10500798 10500797 10500795</p>
	<p>Sash Lift</p> <p><i>NOTE: Screws are included with part numbers listed on the right.</i></p> <p><i>Includes:</i> 1 - Sash lift 2 - #8 x 1" Slotted ovalhead sheet metal screws</p> <p><i>Part numbers listed below are for screws only.</i> Satin Taupe - 11800886, Bronze - 11800888, White - 11800887, Brass - 11800889, Antique Brass - 11800890, Satin Chrome - 11800891, Satin Nickel - 11800894, Oil Rubbed Bronze - 11800893, Polished Chrome - 11800892</p>	<p>Satin Taupe Bronze White Brass Antique Brass Satin Chrome Satin Nickel Oil Rubbed Bronze Polished Chrome</p>	<p>10500598 10500557 10500556 10500558 10500597 10500596 10500602 10500601 10500595</p>

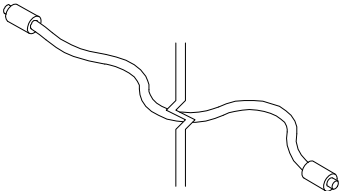
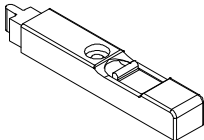
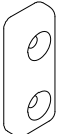
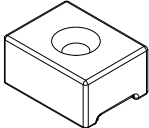
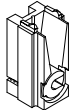
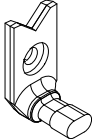
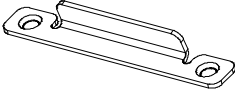
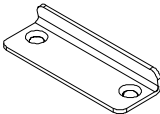
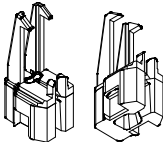
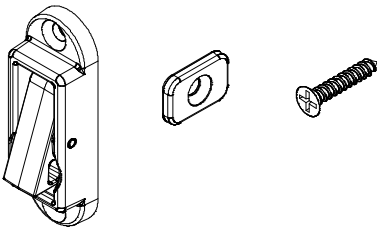
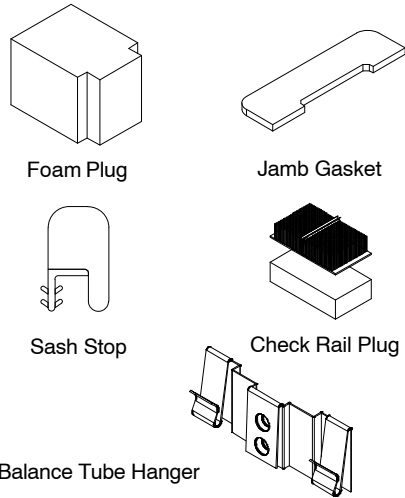
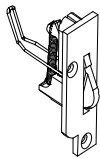
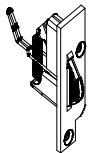
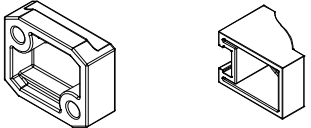
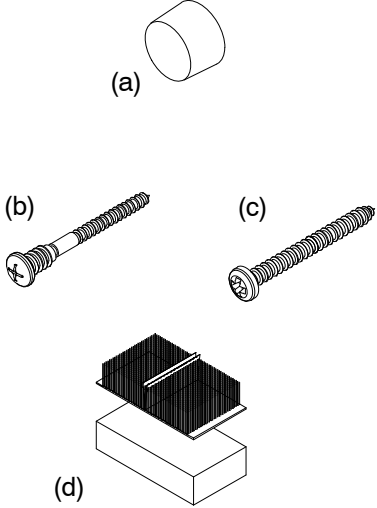

ILLUSTRATION NOT TO SCALE	DESCRIPTION	OPER./COLOR	PART NO.
	<p>Multi-Point Tilt Latch Operation Cord <i>Measure overall length for special sizes call Marvin to order</i></p> <p>CN16 CN20 CN24 CN26 CN28 CN30 CN32 CN36 CN40</p>		<p>10500616 10500620 10500624 10500626 10500628 10500630 10500632 10500636 10500640</p>
	<p>Top Sash Tilt Latch Assembly <i>Ultimate Wood usage 2000 – present</i> <i>Includes:</i> 1 – Tilt latch assembly 1 – #7x1 1/4" Phillips flathead wood screws</p>	Beige	10500555
	<p>Sash Limiter <i>Includes:</i> 1 – Sash limiter 2 – #7 x 3/4" Phillips stainless steel screws</p>	Beige	10500515
	<p>Sash Stop, Vinyl <i>Includes:</i> 1 – Sash Stop 1 – #8X1" Phillips flathead wood screw</p>	Beige	10500525
	<p>Clutch Assembly</p>		10500551
	<p>Clutch Pivot <i>Includes:</i> 1 – Clutch pivot 1 – #7x1 1/4" Phillips trimhead self tapping screw</p>		10500550
	<p>Sill Bracket <i>Includes fasteners:</i> 2 – #7x3/4" Phillips flathead SS screws (Beige- 11800763) (White-11800764)</p>	Beige White	11841103 11841104
	<p>Sill Bracket <i>Includes:</i> 1 – Sill bracket 2 – #7 x 7/8" Flathead stainless steel screws</p>		10500526
	<p>Balance Tube Shock Pad Assembly</p>		11860279

ILLUSTRATION NOT TO SCALE	DESCRIPTION	COLOR	PART NO.
	<p>Window Opening Control Device Kit Also used for Insert</p> <p><i>Includes:</i> 2 - Control Devices 2 - Strike Plates 6 - Color Match Screws, #7 x 7/8"</p>	<p>White Bronze Brass Satin Chrome Polished Chrome Antique Brass Satin Taupe Oil Rubbed Bronze Satin Nickel</p>	<p>11850640 11850641 11850642 11850643 11850644 11850645 11850646 11850647 11850648</p>
 <p>Foam Plug</p> <p>Jamb Gasket</p> <p>Sash Stop</p> <p>Check Rail Plug</p> <p>Balance Tube Hanger</p>	<p>Replacement Jamb Carrier Package</p> <p><i>Includes:</i> 2 - Foam Plug, Interior Jamb Carrier Track (10500504)* 2 - Foam Gasket Jamb Carrier(10500510)* 2 - Sash Stop V784 (used on bottom sash) (10500524 Beige, 10500523 White) 2 - Check rail plug & Pile weather strip (10500508 Beige, 10500509 White) 2 - Balance Tube Hanger (11860044) 2 - #7 x 7/8" A-17 FH screws (11800727) 1 - Instruction</p> <p>*Foam Plug available in white only. Foam Gasket available in beige only.</p>	<p>Beige White</p>	<p>11850125 11850124</p>

NOTE: Reference the End Plate Assembly chart to pair the correct replacement assembly with size of window.

ILLUSTRATION	DESCRIPTION	ILLUSTRATION	DESCRIPTION
 <p>LH shown</p>	<p>A. Wood Tilt Latch End Plate Assembly – Beige</p> <p><i>Includes fasteners: 2 – #6x5/8" Phillips flathead wood screws</i></p> <p>LH 10500666 RH 10500665</p>	 <p>RH shown</p>	<p>B. Wood Tilt Latch End Plate Assembly – BK Over mold</p> <p><i>Includes fasteners: 1 – #6x1 1/2" Phillips flathead screw Beige (11806136) 1 – #6x5/8" Phillips flathead screw (11800519)</i></p> <p>LH 10500704 RH 10500705</p>

End Plate Assembly Chart										
CN		16	20	24	26	28	30	32	36	40
	Wood FS	21 3/8	25 3/8	29 3/8	31 3/8	33 3/8	35 3/8	37 3/8	41 3/8	45 3/8
12	33	A	A	A	A	A	A	A	A	A
14	37	A	A	A	A	A	A	A	A	A
16	41	A	A	A	A	A	A	A	A	A
18	45	A	A	A	A	A	A	A	A	A
20	49	A	A	A	A	A	A	A	A	A
22	53	A	A	A	A	A	A	A	A	A
24	57	A	A	A	A	A	A	A	A	A
26	61	A	A	A	A	A	A	A	A	A
28	65	A	A	A	A	A	A	B	B	B
30	69	A	A	A	A	A	A	B	B	B
32	73	A	A	A	A	A	A	B	B	B
34	77	A	A	A	A	A	A	B	B	B
36	81	A	A	A	A	A	A	B	B	B
-	85	B	B	B	B	B	B	B	B	
40	89	B	B	B	B	B	B	B	B	
42	93	B	B	B	B	B	B	B	B	
-	97	B	B	B	B	B	B	B	B	

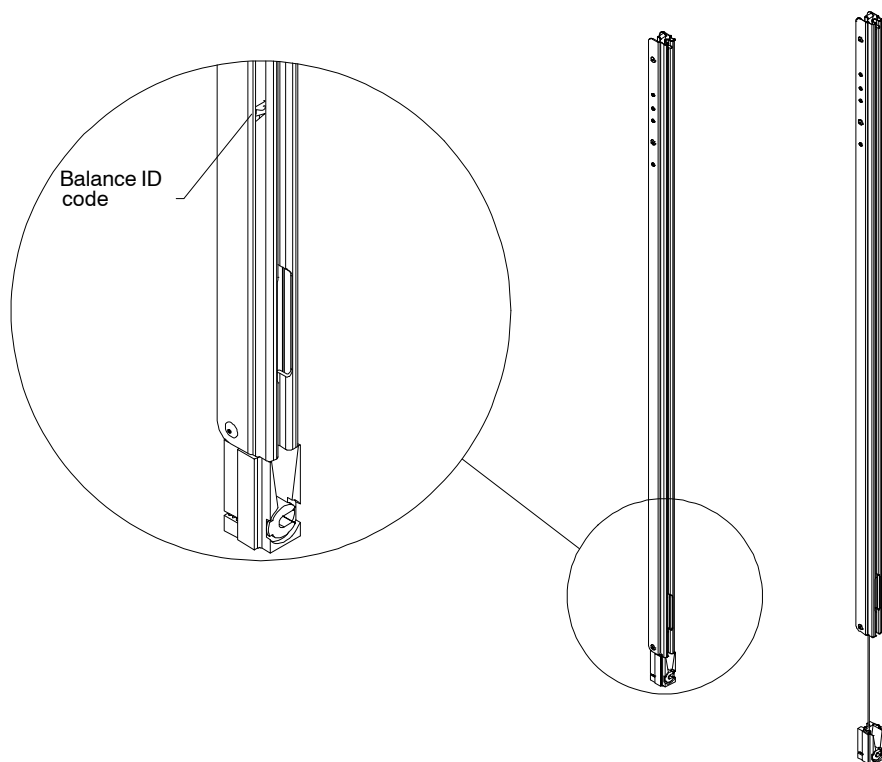
ILLUSTRATION NOT TO SCALE	DESCRIPTION	COLOR	PART NO.
 <p>Retainer Ogee Lug</p>	<p>Ogee Lug Kit <i>Includes:</i> 2 – Ogee Lugs – 10500673 2 – Retainers – 10500672 2 – #7 x 1 1/4" Panhead screws (11807119)</p>		11894145
 <p>(a) (b) (c) (d)</p>	<p>Installation Pkgs for Insert Units Only <i>Includes:</i> Operator 4 – 3/8" Flathead plugs (interior) (a) Wood Operator 2 – 5/16" #10 x 2 1/2" jamb jack screws (b)11882360 4 – #7 x 2" Phillips panhead installation screws (c)11807121 2 – Jamb liner check rail pads (d)</p> <p>Transom 4 – 3/8" Flathead plugs (interior) (a) 4 – #7 x 2" Phillips panhead installation screws (c)</p> <p>Picture 16 – #7 x 2" Phillips panhead installation screws (c)</p>	<p>Beige White</p>	<p>Operator 11900550 11900557</p> <p>Transom 11900537</p> <p>Picture 11900538</p>
	<p>3/8" Flat Head Plug – Insert Units</p>	<p>See Miscellaneous Mouldings and Extrusions chapter for available part numbers.</p>	

Balance tubes for standard units may be ordered by part number. To determine the part number, locate the ID code from the existing tube (see illustration below) and use the chart on the next page.

Balance tubes for special sized units or insert units are not available by part number.

When ordering balance tubes for special sized units, please provide **ALL** the following information:

1. Provide the original order number when possible
2. Provide glass height or tube assembly overall.
3. Provide balance ID code. The ID code is imprinted on the tube (see illustration).
NOTE: If the balance is oversized, a balance ID will not be available. In this case, provide the glass width, height, and makeup.
4. Specify top or bottom sash.
NOTE: The balance for the top sash is in the exterior track and has a mill finish color. The balance for the bottom sash is in the interior track and has a beige or white color.
5. If the tube is for the bottom sash, specify color (beige or white).
6. Specify quantity. Do **NOT** specify as pairs or sets. If one tube is needed, specify:quantity 1. If four tubes are needed, specify:quantity 4.



Part numbers listed below are for one balance only. Each sash requires two balances.

Mill Balance Tube Part Numbers for the Top Sash													
Spring Weight AA		Spring Weight A		Spring Weight B		Spring Weight C		Spring Weight D		Spring Weight E		Spring Weight F	
CN	Part #	CN	Part #	CN	Part #	CN	Part #	CN	Part #	CN	Part #	CN	Part #
12	10696612	12	10695012	12	10695112	12	10695212	12	10695312	-	-	-	-
14	10696614	14	10695014	14	10695114	14	10695214	14	10695314	14	10695414	-	-
16	10696616	16	10695016	16	10695116	16	10695216	16	10695316	16	10695416	-	-
18	10696618	18	10695018	18	10695118	18	10695218	18	10695318	18	10695418	-	-
20	10696620	20	10695020	20	10695120	20	10695220	20	10695320	20	10695420	-	-
22	10696622	22	10695022	22	10695122	22	10695222	22	10695322	22	10695422	22	10695522
24	10696624	24	10695024	24	10695124	24	10695224	24	10695324	24	10695424	24	10695524
26	10696626	26	10695026	26	10695126	26	10695226	26	10695326	26	10695426	26	10695526
28	10696628	28	10695028	28	10695128	28	10695228	28	10695328	28	10695428	28	10695528
30	10696630	30	10695030	30	10695130	30	10695230	30	10695330	30	10695430	30	10695530
32	10696632	32	10695032	32	10695132	32	10695232	32	10695332	32	10695432	32	10695532
34	10696634	34	10695034	34	10695134	34	10695234	34	10695334	34	10695434	34	10695534
36	10696636	36	10695036	36	10695136	36	10695236	36	10695336	36	10695436	36	10695536

Beige Balance Tube Part Numbers for the Bottom Sash													
Spring Weight AA		Spring Weight A		Spring Weight B		Spring Weight C		Spring Weight D		Spring Weight E		Spring Weight F	
CN	Part #	CN	Part #	CN	Part #	CN	Part #	CN	Part #	CN	Part #	CN	Part #
12	10696712	12	10696012	12	10696112	12	10696212	12	10696312	-	-	-	-
14	10696714	14	10696014	14	10696114	14	10696214	14	10696314	14	10696414	-	-
16	10696716	16	10696016	16	10696116	16	10696216	16	10696316	16	10696416	-	-
18	10696718	18	10696018	18	10696118	18	10696218	18	10696318	18	10696418	-	-
20	10696720	20	10696020	20	10696120	20	10696220	20	10696320	20	10696420	-	-
22	10696722	22	10696022	22	10696122	22	10696222	22	10696322	22	10696422	22	10696522
24	10696724	24	10696024	24	10696124	24	10696224	24	10696324	24	10696424	24	10696524
26	10696726	26	10696026	26	10696126	26	10696226	26	10696326	26	10696426	26	10696526
28	10696728	28	10696028	28	10696128	28	10696228	28	10696328	28	10696428	28	10696528
30	10696730	30	10696030	30	10696130	30	10696230	30	10696330	30	10696430	30	10696530
32	10696732	32	10696032	32	10696132	32	10696232	32	10696332	32	10696432	32	10696532
34	10696734	34	10696034	34	10696134	34	10696234	34	10696334	34	10696434	34	10696534
36	10696736	36	10696036	36	10696136	36	10696236	36	10696336	36	10696436	36	10696536

White Balance Tube Part Numbers for the Bottom Sash													
Spring Weight AA		Spring Weight A		Spring Weight B		Spring Weight C		Spring Weight D		Spring Weight E		Spring Weight F	
CN	Part #	CN	Part #	CN	Part #	CN	Part #	CN	Part #	CN	Part #	CN	Part #
12	10686712	12	10686012	12	10686112	12	10686212	12	10686312	-	-	-	-
14	10686714	14	10686014	14	10686114	14	10686214	14	10686314	14	10686414	-	-
16	10686716	16	10686016	16	10686116	16	10686216	16	10686316	16	10686416	-	-
18	10686718	18	10686018	18	10686118	18	10686218	18	10686318	18	10686418	-	-
20	10686720	20	10686020	20	10686120	20	10686220	20	10686320	20	10686420	-	-
22	10686722	22	10686022	22	10686122	22	10686222	22	10686322	22	10686422	22	10686522
24	10686724	24	10686024	24	10686124	24	10686224	24	10686324	24	10686424	24	10686524
26	10686726	26	10686026	26	10686126	26	10686226	26	10686326	26	10686426	26	10686526
28	10686728	28	10686028	28	10686128	28	10686228	28	10686328	28	10686428	28	10686528
30	10686730	30	10686030	30	10686130	30	10686230	30	10686330	30	10686430	30	10686530
32	10686732	32	10686032	32	10686132	32	10686232	32	10686332	32	10686432	32	10686532
34	10686734	34	10686034	34	10686134	34	10686234	34	10686334	34	10686434	34	10686534
36	10686736	36	10686036	36	10686136	36	10686236	36	10686336	36	10686436	36	10686536

ULTIMATE WOOD DOUBLE HUNG BALANCES FOR UNITS MANUFACTURED AFTER 1/15/01

ORDERING REPLACEMENT JAMB CARRIERS

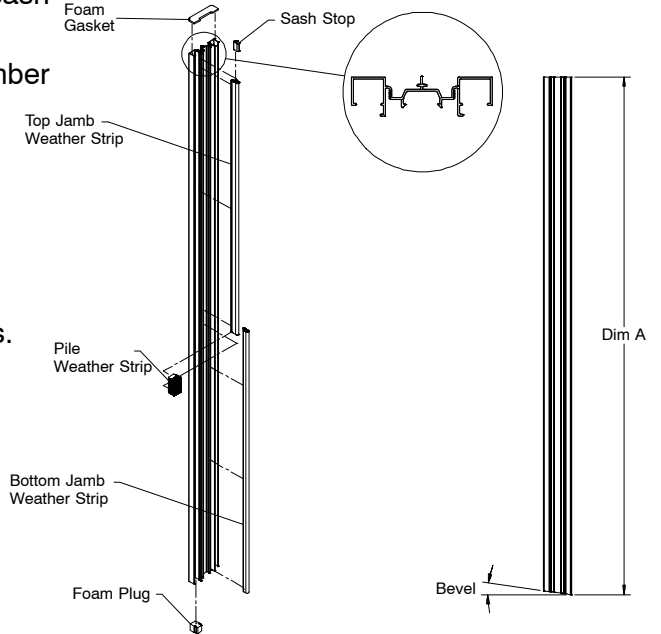
Replacement jamb carriers include a pair of vinyl jamb carriers, jamb weather strip, foam plugs, top gaskets, pile weather strip and sash stops.

Jamb carriers for standard units may be ordered by part number from the chart below.

When ordering jamb carriers for special sized units, please provide the following information:

1. Provide original order number, when available.
2. Provide length (see Dimension A as shown)
3. Provide color (beige or white).
4. If unequal glass heights, provide both glass heights.

NOTE: Jamb carriers must be ordered in pairs.



Glass Height (one sash)	Beige Part Number	White Part Number
12" pair	10697012	10696912
14" pair	10697014	10696914
16" pair	10697016	10696916
18" pair	10697018	10696918
20" pair	10697020	10696920
22" pair	10697022	10696922
24" pair	10697024	10696924
24/36" pair	10697060	10696960
26" pair	10697026	10696926
28" pair	10697028	10696928
30" pair	10697030	10696930
32" pair	10697032	10696932
34" pair	10697034	10696934
36" pair	10697036	10696936

NOTE: Balance tube hangers replaced S-hooks in February, 2008.

Replacement Jamb Carrier Hardware Assemblies Complete include a pair of vinyl jamb carriers, jamb weather strip, pile weather strip, foam plugs, top gaskets, sash stops, balance tube hangers and balance tubes.

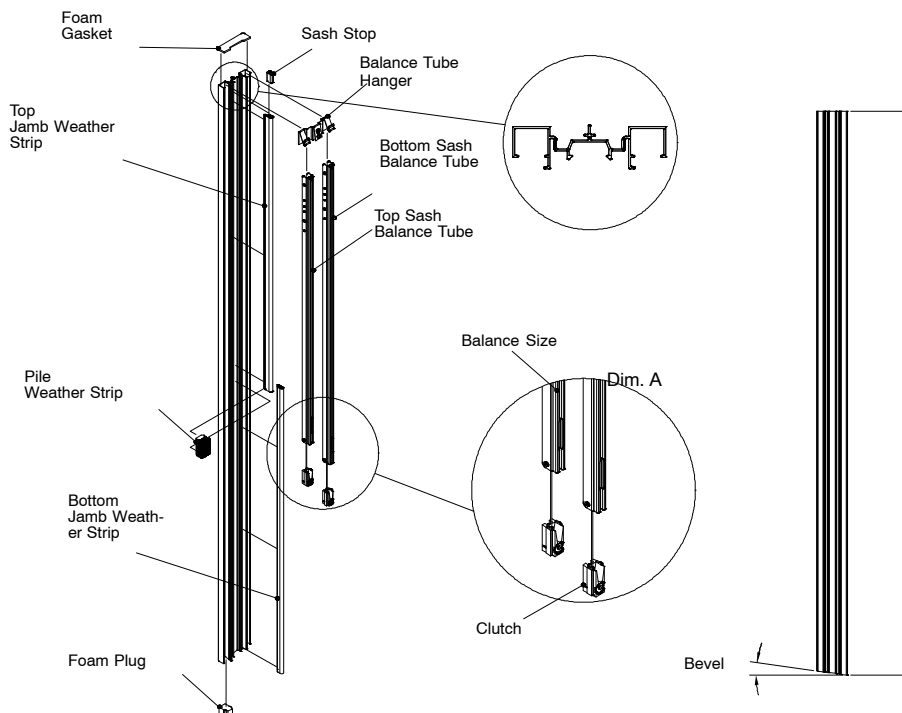
Assemblies for standard units may be ordered by part number from the chart on the next page. .

NOTE: Jamb carrier hardware assemblies must be ordered in pairs.

When ordering jamb carrier hardware assemblies complete for special units, include the following information:

1. Original order number, if available
2. Provide length (see dimension A as shown) or rough opening height.
3. If unequal glass heights, provide both heights.
4. Provide balance ID code (s)*. The ID code is imprinted on the tube (see illustration)
5. Provide jamb carrier hardware color (beige or white)

* If the balances are over sized, a balance ID will not be available. In this case, provide the glass width, height and makeup



Ultimate Wood Double Hung Jamb Carrier Hardware Assemblies

CN Height	Spring Weight A	Spring Weight B	Spring Weight C	Spring Weight D	Spring Weight E	Spring Weight F
12 pair Beige	10535012	10535112	10535212	10535312		
14 pair Beige	10535014	10535114	10535214	10535314	10535414	
16 pair Beige	10535016	10535116	10535216	10535316	10535416	
18 pair Beige	10535018	10535118	10535218	10535318	10535418	
20 pair Beige	10535020	10535120	10535220	10535320	10535420	
22 pair Beige	10535022	10535122	10535222	10535322	10535422	10535522
24 pair Beige	10535024	10535124	10535224	10535324	10535424	10535524
24/36 pair Beige	10535060	10535160	10535260	10535360	10535460	10535560
26 pair Beige	10535026	10535126	10535226	10535326	10535426	10535526
28 pair Beige	10535028	10535128	10535228	10535328	10535428	10535528
30 pair Beige	10535030	10535130	10535230	10535330	10535430	10535530
32 pair Beige	10535032	10535132	10535232	10535332	10535432	10535532
34 pair Beige	10535034	10535134	10535234	10535334	10535434	10535534
36 pair Beige	10535036	10535136	10535236	10535336	10535436	10535536
12 pair White	10534012	10534112	10534212	10534312		
14 pair White	10534014	10534114	10534214	10534314	10534414	
16 pair White	10534016	10534116	10534216	10534316	10534416	
18 pair White	10534018	10534118	10534218	10534318	10534418	
20 pair White	10534020	10534120	10534220	10534320	10534420	
22 pair White	10534022	10534122	10534222	10534322	10534422	10534522
24 pair White	10534024	10534124	10534224	10534324	10534424	10534524
24/36 pair White	10534060	10534160	10534260	10534360	10534460	10534560
26 pair White	10534026	10534126	10534226	10534326	10534426	10534526
28 pair White	10534028	10534128	10534228	10534328	10534428	10534528
30 pair White	10534030	10534130	10534230	10534330	10534430	10534530
32 pair White	10534032	10534132	10534232	10534332	10534432	10534532
34 pair White	10534034	10534134	10534234	10534334	10534434	10534534
36 pair White	10534036	10534136	10534236	10534336	10534436	10534536

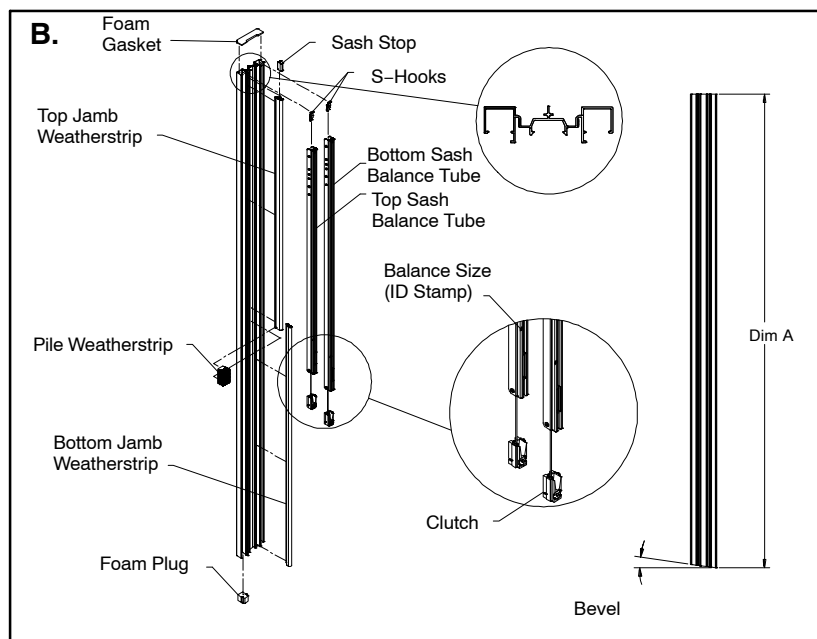
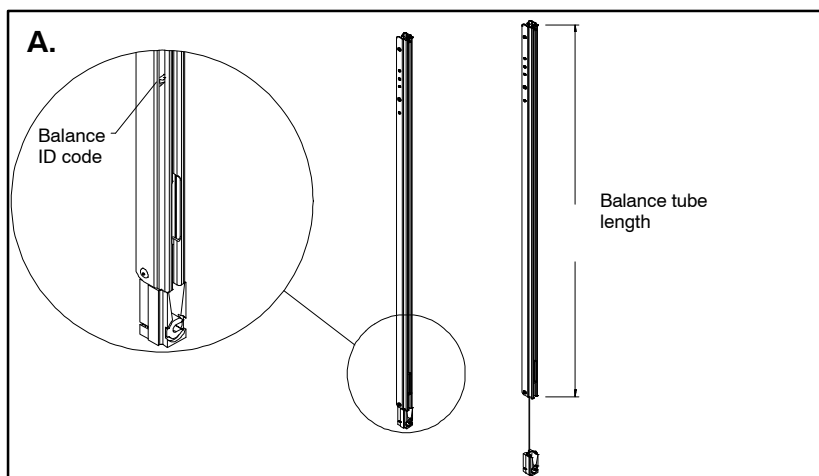
Balance Tubes or Jamb Carrier Hardware Assemblies for Insert units are not available by part number.

To order balances specify:

1. Original order number.
2. Balance tube length
3. Balance ID code; information is imprinted on tube, (see illustration A below).
4. Top or bottom sash. Balance in *exterior* track has a mill finish tube for top sash, balance in *interior* track has a beige color tube for bottom sash.

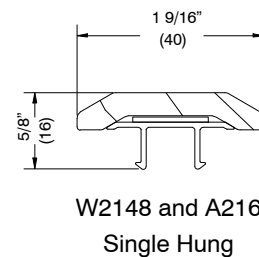
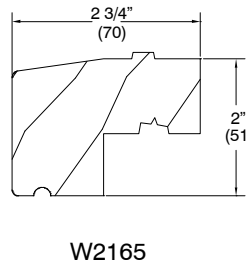
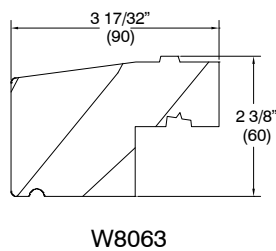
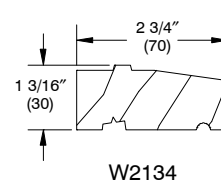
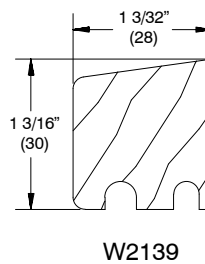
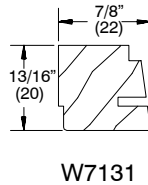
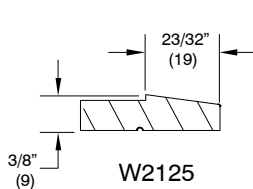
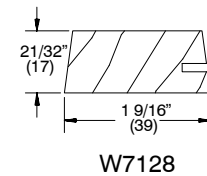
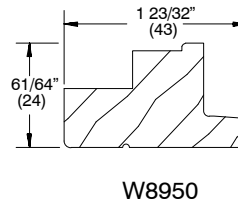
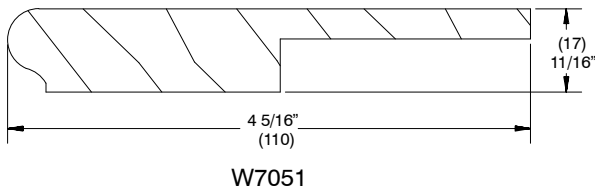
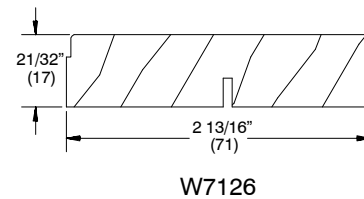
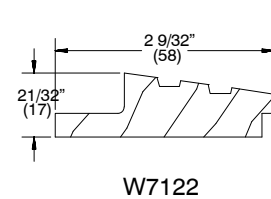
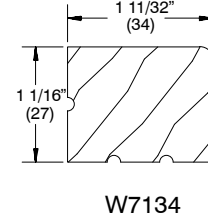
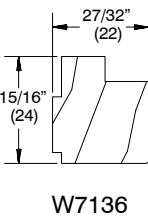
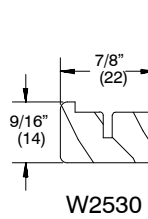
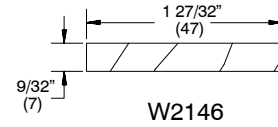
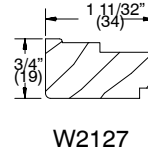
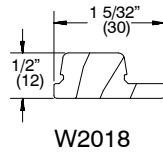
To order Jamb Carrier Hardware Assemblies specify:

1. Original order number.
2. Length(dimension A from illustration B)
3. Glass height and width of one sash (daylight opening + 1 1/16"). Measure both sash if they are not of equal size.
4. Tube ID stamp for top and bottom sash balance spring weights. (see illustration B for location of ID.)



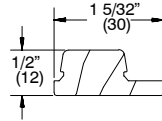
WOOD PARTS – ULTIMATE WOOD DOUBLE HUNG AND SINGLE HUNG

Ultimate Wood Double Hung and Single Hung	
Wood Jamb Filler Operator – longest length available is 60"	W2018
Jamb Liner	W2127
Sill Liner	W2146
Head Jamb Parting Stop – longest length available is 60"	W2530
Head Jamb Parting Stop/Transom – longest length available is 60"	W7136
Interior Sash Stop – Pic./Transom	W7134
Sill Filler – Transom	W7122
Jamb Filler – Transom	W7126
Stool Field Applied	W7051
Jamb Blind Stop	W8950
Header Jamb Exterior Filler 2" Pic.	W7128
Top Blind Stop	W2125
Jamb Exterior Filler, 2" Picture	W7131
Sill Nosing	W2139
Subsill	W2134
2" Extended Thick Simulated Subsill	W8063
2" Thick Simulated Subsill	W2165
Single Hung Jamb Carrier Filler used with A216 (shown)	W2148

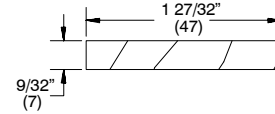


WOOD PARTS – ULTIMATE WOOD DOUBLE HUNG AND SINGLE HUNG INSERT

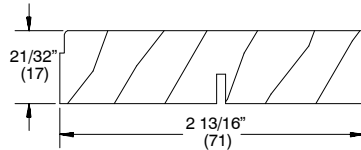
Ultimate Wood Double Hung Insert and Insert Single Hung	
Wood Jamb Filler Operator – longest length available is 60"	W2018
Sill Liner	W2146
Jamb Filler – Transom	W7126
Jamb Blind Stop	W8950
Sill Liner – Transom/Picture	W2179
Exterior Sill Trim	W8599
Exterior Side and Top Trim	W8601
Exterior Mull Trim – Vertical	W8602
Exterior Mull Trim – Vertical	W8604
Single Hung Jamb Carrier Filler used with A216 (shown)	W2148



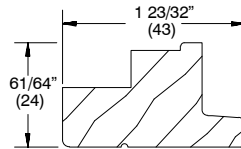
W2018



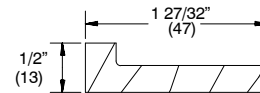
W2146



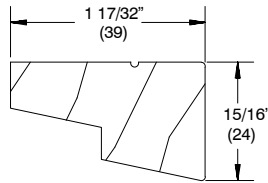
W7126



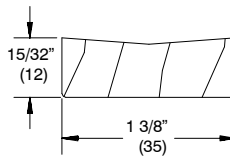
W8950



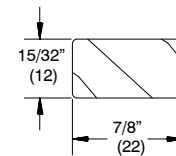
W2179



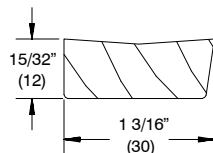
W8599



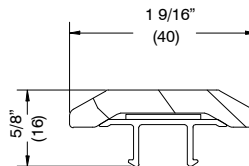
W8601



W8602



W8604

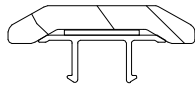


W2148
(shown with A216)
Single Hung

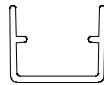
ULTIMATE WOOD DOUBLE HUNG AND SINGLE HUNG WOOD DOUBLE HUNG INSERT

When ordering parts specify:



1. Original order number
2. profile number;
3. call number or rough opening;
4. length;



A216 Jamb Liner
(shown with W2148)




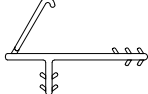
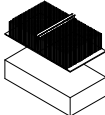
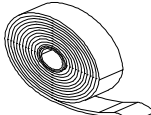
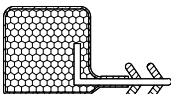
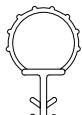
V1172
Top Sash Stop

ILLUSTRATION <i>NOT TO SCALE</i>	DESCRIPTION	COLOR	PART NO.
	Sash Retainer – Picture and Transom V130 – 100" (2540)		15350099
	Connecting Barb – Picture and Transom V803 – specify length per lineal foot		15812999

WEATHER STRIP ULTIMATE WOOD DOUBLE HUNG/SINGLE HUNG/INSERT UNITS

When ordering weather strip specify:

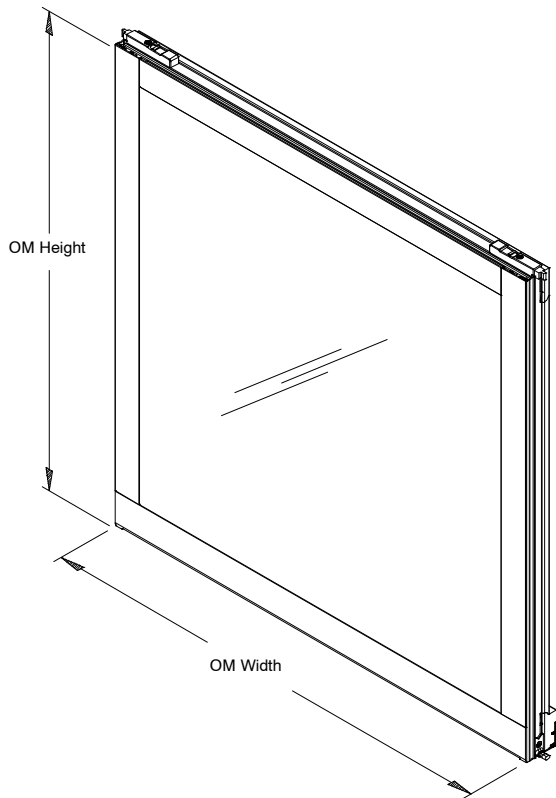
1. Original order number;
2. quantity;
3. part number;
4. description.

ILLUSTRATION <i>NOT TO SCALE</i>	DESCRIPTION	Length/Color	PART NUMBER
	Frame Weather Strip V2838 100" (2540)	Beige White	15356998 15356999
	Head Jamb Part Stop Weather Strip V945 70" (1778)	Beige	15352470
	Check Rail Plug & Pile Weatherstrip – Insert units 3/4" x 13/16" x 1 1/2"	Beige White	10500508 10500509
	Frame Weather Strip – Picture/Transom MISC – 03692 – Gray	25' Roll	11406223
	Top Check Rail and Transom Frame Weather Strip V031 – Beige	Specify Length	15351799
	Bottom Rail or Frame Weather Strip V147 – Beige	150" (3810)	15351699

ULTIMATE WOOD DOUBLE HUNG AND SINGLE HUNG AND PICTURE OR TRANSOM SASH

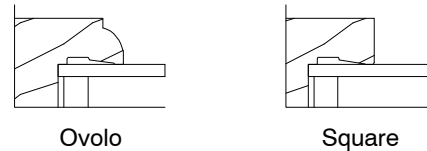
When ordering replacement sash specify:

1. Original order number;
2. which sash is being replaced for double/single hung – top, bottom or pair;
3. size
 - a. top or bottom (call number or OM of sash)
 - b. pair (call number or sash opening – indicate if unequal sash height)
4. size (Picture or Transom)–(call number or OM of sash)
5. glazing;
6. interior/exterior finish
7. Sticking (see illustration).
 - a. ovolo
 - b. square



Exterior View
 (top sash shown)

Sticking Profiles
Standard



ORDERING REPLACEMENT FULL SCREENS FOR ULTIMATE WOOD DOUBLE HUNG/SINGLE HUNG AND INSERT UNITS

Full screens are standard with aluminum surround and charcoal colored fiberglass 18 x 16 screen mesh. Aluminum mesh is available as an option in black, charcoal, bright aluminum or bright bronze. Determine the outside measurement of the existing screen and find the size that corresponds to the width and height indicated on the following charts. Insert units will use the conversions only, as they are all special sizes. Surrounds are available in bronze, stone white, brown, pebble gray and evergreen.

When ordering a screen specify:

1. Original order number
2. size; – If there is no existing screen to obtain the OM of the screen, determine the size of the screen by using the conversions and chart below. The daylight opening is the measurement of the visible glass.
3. surround color;
4. mesh type (if other than standard).

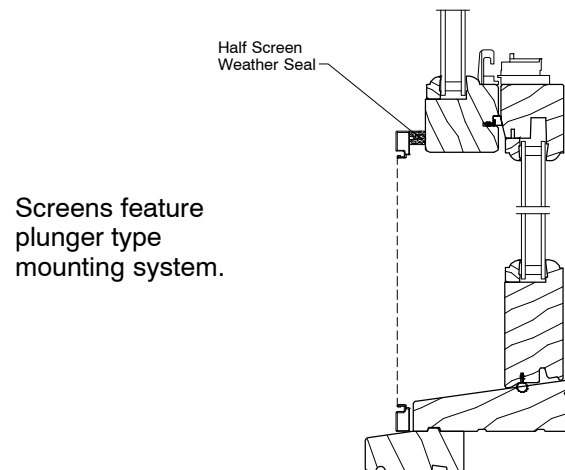
Screen Sizes for Ultimate Wood Double Hung Insert			
Daylight Opening of one sash to OM of screen (if equal height)			
Daylight Width + 4 31/32”(126) = OM Width of Screen Daylight Height x 2 + 9 9/32”(238)= OM Height of Screen			
Screen Sizes for Ultimate Wood Double Hung manufactured after 1/15/01.			
Daylight Opening of one sash (if equal height) to OM of screen.			
Daylight Width + 4 15/16” = OM Width of Screen Daylight Height x 2 + 9 9/32” = OM Height of Screen			
WIDTH		HEIGHT	
SIZE	OM-WIDTH	SIZE	OM-HEIGHT
CN 16	19 7/8”	CN 12	31 5/32”
CN 20	23 7/8”	CN 14	35 5/32”
CN 24	27 7/8”	CN 16	39 5/32”
CN 26	29 7/8”	CN 18	43 5/32”
CN 28	31 7/8”	CN 20	47 5/32”
CN 30	33 7/8”	CN 22	51 5/32”
CN 32	35 7/8”	CN 24	55 5/32”
CN 36	39 7/8”	CN 24/36	67 5/32”
CN 40	43 7/8”	CN 26	59 5/32”
		CN 28	63 5/32”
		CN 30	67 5/32”
		CN 32	71 5/32”
		CN 34	75 5/32”
		CN 36	79 5/32”

HALF SCREENS ULTIMATE WOOD SINGLE HUNG/INSERT SINGLE HUNG

Half screens are standard with aluminum surround and charcoal colored fiberglass 18 x 16 screen mesh. Aluminum mesh is available as an option in black, charcoal, bright aluminum, or bright bronze. Determine the outside measurement of the existing screen. Surrounds are available in bronze, stone white, brown, pebble gray and evergreen.

When ordering screen specify:

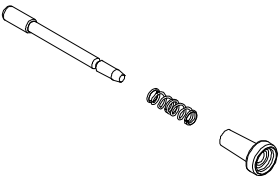
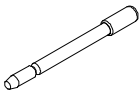


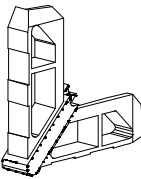



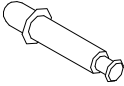


1. size; – If there is no existing screen from which to obtain the OM of the screen, determine the size of the screen by using the conversions below. The daylight opening is the measurement of the visible glass.
2. color;
3. mesh type (if other than standard).

**Ultimate Wood Single Hung/Insert
Single Hung Half Screen Application****Ultimate Wood Single Hung
Manufactured after 1/15/01
Ultimate Wood Single Hung Insert****Daylight Opening to OM of Half Screen**

Daylight Width + 4 15/16" = OM Width of Screen

Daylight Height + 5 13/16" = OM Height of Screen

When ordering parts specify part number and quantity.

ILLUSTRATION NOT TO SCALE	DESCRIPTION	COLOR	PART NO.
	Screen Plunger Kit – 3 pc. <i>Includes: 1 – Plunger Bolt (05070315) 1 – Plunger Spring (05070421) 1 – Plunger Cap (05070308-BK)</i>		11851054
	Screen Plunger Bolt	Mill Finish	05070315
	Spring, Plunger		05070421
	Screen Plunger Cap	Black	05070308
	Corner Key, Screen MISC 051	Stone White Bronze Pebble Bahama Brown Clear Evergreen	11867875 11867862 11867863 11867864 11867866 11867868
	Screen Surround, Aluminum Profile A135 Available in 150" (3810) length	Stone White Bronze Pebble Bahama Brown Evergreen	18801120 15231399 15231150 15231499 15230199
	Screen Crossbar, Aluminum Profile A131 Available in 144" (3658) length	Stone White Bronze Pebble Bahama Brown Evergreen	18801080 15233499 15233399 15233299 15233599
	1/2 Screen Foam Liner Available in 84" (2134) length	Black	10500028
	Top Rail Screen Pin M120	Clear	11867852
	Ultimate Wood Screen Mounting Receptacle M110	Clear	11867851
	Wood Insert Screen Kit Includes 4 screen receptacles and instructions	Clear	11900576

FULL AND HALF OPTIONAL SCREENS FOR ULTIMATE WOOD DOUBLE HUNG/SINGLE HUNG AND INSERT UNITS

Full screens are standard with aluminum surround and Hi-Transparency fiberglass mesh. Aluminum mesh is available as an option in black, charcoal, bright aluminum or bright bronze. Determine the outside measurement of the existing screen. Surrounds are available in all standard and select colors.

When ordering a replacement screen specify:

1. size; – Obtain the OM of the screen, from the exiting unit or determine the size of the screen by using the conversion charts below. The daylight opening is the measurement of the visible glass.
2. surround color;
3. mesh type (if other than standard).

NOTE: All screens feature plunger type mounting system.

FULL AND HALF SCREEN CONVERSIONS FOR ULTIMATE MAGNUM AND IZ3 UNITS

Full Magnum Screen

DLO of one sash (if equal height) to OM of screen.

DLO Width + 4 15/16" = OM Width of Screen
 DLO Height x 2 + 9 1/4" = OM Height of Screen

Full Magnum Screen for Insert

DLO Width + 4 31/32" = OM Width of Screen
 DLO Height x 2 + 9 9/32" = OM Height of Screen
 IO Width – 2 27/32" = OM Width of Screen
 IO Height (Flat Bottom Frame) – 1" or
 (8 degree) – 9/16" = OM Height of Screen

Half Magnum Screen

Daylight Opening to OM of Half Screen

Daylight Width + 4 15/16" = OM Width of Screen
 Daylight Height + 6 1/16" = OM Height of Screen

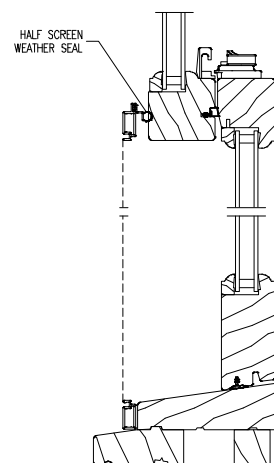
IZ3 Full and Half Magnum Screen

Daylight Opening to OM of Full Screen

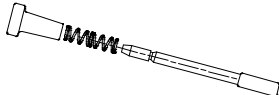
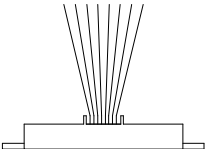


Daylight Width + 6 9/16" = OM Width of Screen
 Daylight Height x 2 + 10 1/16" = OM Height of Screen

Daylight Opening to OM of Half Screen

Daylight Width + 6 9/16" = OM Width of Screen
 Daylight Height + 6 3/32" = OM Height of Screen



When ordering parts specify quantity and part number.

ILLUSTRATION NOT TO SCALE	DESCRIPTION	COLOR	PART NO.
	<p>Plunger and Spring Assembly Used 2/2012 to present Includes: 1 - Plunger bolt (metal) 1 - Plunger bolt cap (black) 1 - Plunger bolt spring</p>	Black	10500706
	<p>Sash Pile Weather Strip V2173 Specify lineal foot</p>	Gray	15607501
	<p>1/2 Screen Weather Strip V2113 Specify lineal foot</p>	Beige	15361399
	<p>Screen Mounting Kit Includes: 6 - Screen Mounting Receptacles (11867851) 1 - Instruction Sheet</p>	Clear	11851128

ORDERING REPLACEMENT ENERGY PANELS FOR ULTIMATE WOOD DOUBLE HUNG AND SINGLE HUNG

If you are replacing an existing energy panel, determine the outside measurement of the existing energy panel. Find the sizes that correspond to the width and height indicated on the following chart. Energy panels are available for Ultimate Wood Double Hung and Single Hung with bronze or stone white aluminum surrounds Replacement parts and turn buttons are available in the Misc Moulding chapter.

When ordering energy panels specify:

1. size; If there is no existing EP to obtain the OM of the panel, determine the size of the EP using the conversion chart below. The daylight opening is a measurement of visible glass.
2. color of surround;
3. glass type.

Ultimate Wood Double Hung and Single Hung			
Units manufactured 1/15/01 to present.			
Daylight Opening to OM of EP			
Daylight Width + 1 1/8" = OM Width of EP		Daylight Height + 1 1/8" = OM Height of EP	
Units manufactured before April 2, 1984			
Daylight Width + 7/8" = OM Width of EP		Daylight Height + 7/8" = OM Height of EP	
NOTE: OM should not include lip.			
WIDTH		HEIGHT	
SIZE	OM WIDTH	SIZE	OM HEIGHT
CN 16	16 1/16"	CN 12	12 1/16"
CN 20	20 1/16"	CN 14	14 1/16"
CN 24	24 1/16"	CN 16	16 1/16"
CN 26	26 1/16"	CN 18	18 1/16"
CN 28	28 1/16"	CN 20	20 1/16"
CN 30	30 1/16"	CN 22	22 1/16"
CN 32	32 1/16"	CN 24	24 1/16"
CN 36	36 1/16"	CN 26	26 1/16"
CN 40	40 1/16"	CN 28	28 1/16"
		CN 30	30 1/16"
		CN 32	32 1/16"
		CN 34	34 1/16"
		CN 36	36 1/16"

ORDERING REPLACEMENT COMBINATIONS AND/OR INSERTS FOR ULTIMATE WOOD DOUBLE HUNG

Combination units are composed of two glass panels and a screen insert. One of the storm panels slides up for self storage when the screen is in use.

To order replacement combinations and/or inserts determine the outside measurement of the existing items or use the following conversions if none exists. Use the following charts based on daylight openings of the primary window sash to determine combination size and component sizes. Aluminum surround on combinations are available in Bronze and Stone White. Charcoal aluminum wire screen is standard. Fiberglass mesh screen is available as an option.

When ordering replacement combinations specify:

1. size; – If there is no existing combination to obtain the OM of the combination, use the conversion charts below. The daylight opening is the measurement of the double hung sash visible glass (provide measurements of both sash if unequal height).
2. color;
3. mesh type (if other than standard);
4. glass type.

Ultimate Wood Double Hung Combination Units.

Ultimate Wood Double Hung units manufactured after 04/16/01

Daylight Opening to OM of Combination

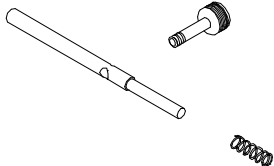

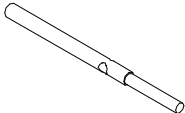


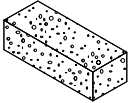
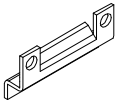


Daylight Width + 4 15/16" = OM Width of
Combination

Daylight Height x 2+9 7/16" = OM Height
of Combination

Width				
Call Number	Combination OM Width	Stationary Panel OM Width	Operator Panel OM Width	Screen OM Width
CN 16	19 7/8"	16 5/8"	17 1/4"	16 5/8"
CN 20	23 7/8"	20 5/8"	21 1/4"	20 5/8"
CN 24	27 7/8"	24 5/8"	25 1/4"	24 5/8"
CN 26	29 7/8"	26 5/8"	27 1/4"	26 5/8"
CN 28	31 7/8"	28 5/8"	29 1/4"	28 5/8"
CN 30	33 7/8"	30 5/8"	31 1/4"	30 5/8"
CN 32	35 7/8"	32 5/8"	33 1/4"	32 5/8"
CN 36	39 7/8"	36 5/8"	37 1/4"	36 5/8"
CN 40	43 7/8"	40 5/8"	41 1/4"	40 5/8"
Height				
Call Number	Combination OM Height	Stationary Panel OM Height	Operator Panel OM Height	Screen OM Height
CN 12	31 5/16"	12 7/16"	13"	12 7/16"
CN 14	35 5/16"	14 7/16"	15"	14 7/16"
CN 16	39 5/16"	16 7/16"	17"	16 7/16"
CN 18	43 5/16"	18 7/16"	19"	18 7/16"
CN 20	47 5/16"	20 7/16"	21"	20 7/16"
CN 22	51 5/16"	22 7/16"	23"	22 7/16"
CN 24	55 5/16"	24 7/16"	25"	24 7/16"
CN 24/36	67 5/16"	24 7/16"	37"	36 7/16"
CN 26	59 5/16"	26 7/16"	27"	26 7/16"
CN 28	63 5/16"	28 7/16"	29"	28 7/16"
CN 30	67 5/16"	30 7/16"	31"	30 7/16"
CN 32	71 5/16"	32 7/16"	33"	32 7/16"
CN 34	75 5/16"	34 7/16"	35"	34 7/16"
CN 36	79 5/16"	36 7/16"	37"	36 7/16"

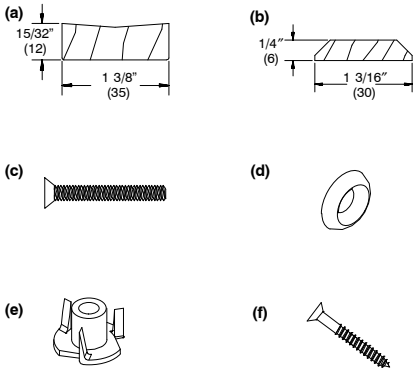
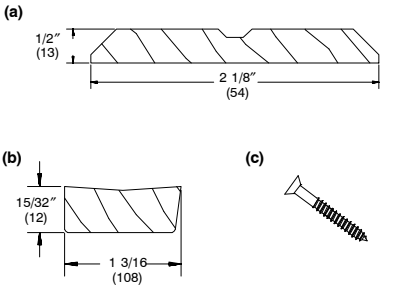
When ordering parts specify:

1. part number;
2. quantity.

ILLUSTRATION NOT TO SCALE	DESCRIPTION	OPERATION COLOR	PART NO.
	<p>Knob, Bolt and Spring Assembly Includes: 2 – Aluminum knobs – 1/2" length 2 – Combination bolt and spring assemblies</p>		11900515
	<p>Knurl Knob For bolt and spring assembly Includes: 2 – Knobs – 1/2" length</p>	Aluminum Stainless Steel	11101705 03050111
	<p>Bolt For bolt and spring assembly</p>	Aluminum Stainless Steel	11101700 03050112
	<p>Turn Latch M062 Wood only</p>	LH RH	11860411 11860311
	<p>Hook, Long Includes: 1 – Hook 2 – Rivets (01060758)</p>	Mill Finish	11040100
	<p>Pad, Hook M601 3/8"x1/2"x1 5/16"</p>	White	10500201
	<p>Strike, Stationary Panel M600 Includes: 1 – Strike 2 – Rivets (01060758)</p>	Mill Finish	11040365
	<p>Dual Seal Weather Strip, Center Rail V116 Color: White</p>	84" (2134)	15828400
	<p>Operator Panel Track V057 NOTE: Specify left, right, top, bottom or set</p>	Black White	15222200 15222100

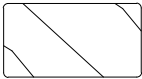
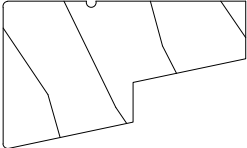
When ordering kits and parts specify original order number and:

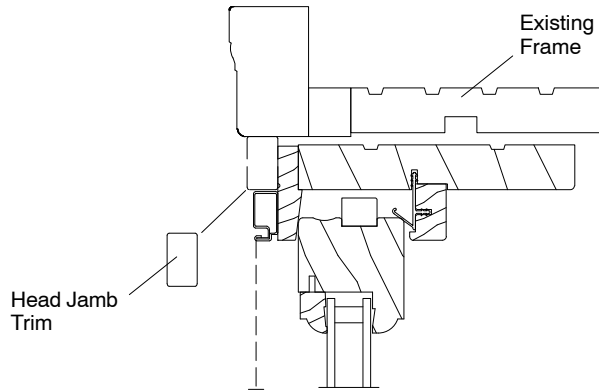
1. Part number
2. Quantity

ILLUSTRATION NOT TO SCALE	DESCRIPTION	PART NO.
	<p>Wood 120" Vertical Mull Kits</p> <p>Includes:</p> <ul style="list-style-type: none"> 1-Exterior Vertical Mull Trim 120" (3048) W8601(a) 30328399 1-Interior Vertical Mull Trim 120" (3048) W1065 (b) 30803098 1-#10 x 1 1/4" Machine Screw (c) 05060500 1-Finish Washer (d) 05080311 1-#10 - 24 Tee Nut (e) 05080251 5-#7 x 7/8" - Phillips Flathead Wood Screw (f) 11800778 	<p>11900553</p>
	<p>Wood 120" Horizontal Mull Kits</p> <p>Includes:</p> <ul style="list-style-type: none"> 1 - Interior Horizontal Mull Trim 120" (3048) W1243 (a) 33730399 1 - Exterior Horizontal Mull Trim 120" (3048) W8604 (b) 30328199 5-#7 x 7/8" - Phillips Flathead Wood Screw (c) 11800778 	<p>11900554</p>

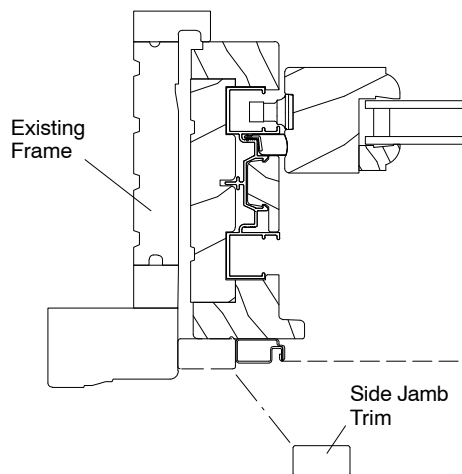
When ordering Kits specify original order number and:

1. Part number
2. Quantity

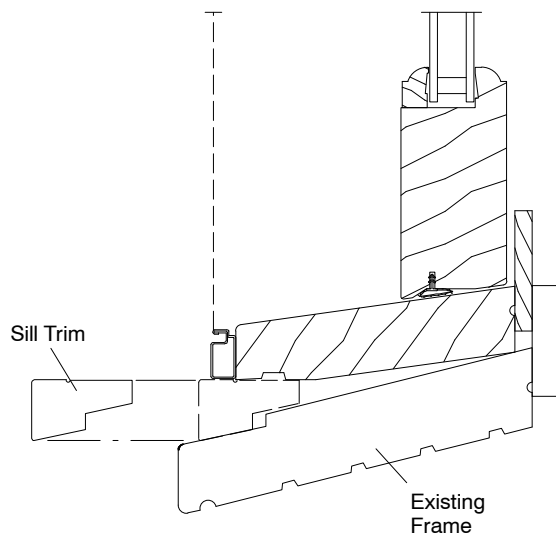
Illustrations (not to scale)	DESCRIPTION	PART NO.
 <p data-bbox="186 510 586 537">Exterior Side and Top Trim (W8602)</p>	<p data-bbox="740 365 1240 392">Wood 36" x 57" Exterior Trim Kit, Insert</p> <p data-bbox="740 401 837 426">Includes:</p> <ul style="list-style-type: none"> <li data-bbox="773 432 1224 457">1 – Exterior Top Trim Sill W8602 – 36" (914) <li data-bbox="773 464 1252 489">2 – Exterior Side Trim W8602 – 57 1/4" (1454) <li data-bbox="773 495 1182 520">1 – Exterior Sill Trim W8599 – 37" (940) 	<p data-bbox="1382 428 1500 453">11900573</p>
 <p data-bbox="245 795 529 823">Exterior Sill Trim (W8599)</p>	<p data-bbox="740 539 1240 567">Wood 44" x 77" Exterior Trim Kit, Insert</p> <p data-bbox="740 575 837 600">Includes:</p> <ul style="list-style-type: none"> <li data-bbox="773 606 1235 632">1 – Exterior Top Trim Sill W8602 – 44" (1118) <li data-bbox="773 638 1252 663">2 – Exterior Side Trim W8602 – 77 1/4" (1962) <li data-bbox="773 669 1192 695">1 – Exterior Sill Trim W8599 – 45" (1143) 	<p data-bbox="1382 598 1500 623">11900574</p>
	<p data-bbox="740 709 1182 737">Wood 120" Exterior Trim Kit, Insert</p> <p data-bbox="740 745 837 770">Includes:</p> <ul style="list-style-type: none"> <li data-bbox="773 777 1252 802">1 – Exterior Top Trim Sill W8602 – 120" (3048) <li data-bbox="773 808 1224 833">2 – Exterior Side Trim W8602 – 120" (3048) <li data-bbox="773 840 1208 865">1 – Exterior Sill Trim W8599 – 120" (3048) 	<p data-bbox="1382 768 1500 793">11900575</p>



Head Jamb Trim



Side Jamb Trim



Sill Trim

FOR ULTIMATE WOOD UNITS MANUFACTURED PRIOR TO 4/2001

Combination units are composed of two glass panels and a screen insert. One of the storm panels slides up for self storage when the screen is in use.

When ordering parts specify:

1. part number;
2. quantity.

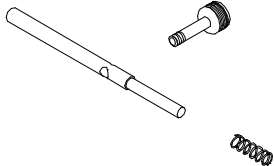




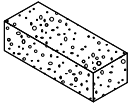

ILLUSTRATION NOT TO SCALE	DESCRIPTION	OPERATIONCOL- OR	PART NO.
	<p>Knob, Bolt and Spring Assembly <i>Includes:</i> 2 - Aluminum knobs - 1/2" length 2 - Combination bolt and spring assemblies</p>	<p>Mill Finish</p>	<p>11900521</p>
	<p>Knob, Aluminum For bolt and spring assembly <i>Includes:</i> 2 - Aluminum knobs - 1/2" length</p>	<p>Mill Finish</p>	<p>11101701</p>
	<p>Knob, Stainless Steel For bolt and spring assembly - 1/2" length</p>	<p>Stainless Steel</p>	<p>03050113</p>
	<p>Leaf Spring M0104</p>		<p>11868835</p>
	<p>Finger Pull, Clear V254</p>		<p>11860350</p>

ILLUSTRATION NOT TO SCALE	DESCRIPTION	PART NUMBER	
	Pad, Top Rail M601 Color: White	3/8"x1/2"x1 5/16"	10500201
	Pad, Bottom Rail M601 Color: White	3/8"x1/2"x1 7/16"	NA
	Dual Seal Weather Strip, Center Rail V116 Color: White	84" (2134)	15828400

When ordering panel track specify:

1. profile;
2. call number or OM of combination;
3. color;
 - a. V057 – black 15222200
 - b. V057 – white 15222100
 - c. V158 – white only 16186400
4. left, right, top or bottom or set.



V057
Operator Panel Track



V158
Stationary Panel Track