

Essential Through Jamb Drilling

Field Applied Instruction



IMPORTANT: These instructions are intended to be used in the event that installation holes were not pre-drilled at the factory.

Tools and Parts Needed

Safety Glasses	Power Drill
Drill Jig (included with kit)	Pencil
Tape Measure	Utility Knife
3/16", 11/32", and 3/8" Drill Bits	

Note: Do not install the unit prior to drilling holes. Remove any interior accessories prior to drilling.

Note on Direct Glaze Polygon and Round Top units: Drilling jig must be modified prior to use. See modifying jig on bottom of this page..

Note: Drilling jig has limited use. Recommend one jig per unit. Jig cannot be used for Casement/Awning units.

Hole Spacing Chart

Use this chart as a reference for proper installation hole spacing.

Product	Jamb Spacing	Head Jamb Spacing
Direct Glaze Polygon	4" (102) from each end. Additional holes evenly spaced along jamb, not to exceed 18 3/4" (476) between brackets.	4" (102) from each end. Additional holes evenly spaced along head jamb, not to exceed 18 3/4" (476) between brackets.
Sliding Window Pictures and Transoms	4" (102) from each end (Units with a frame height larger than 29 1/2" (749) need additional jamb hole at center.)	Units with a frame width equal to or greater than 41 1/2" (1054) will need 2 holes at head jamb spaced 14 9/16" (370) from center.
Gliders	4" (102) from each end (Units with a frame height larger than 29 1/2" (749) need additional hole at center.)	Units with a frame width greater than 47 1/2" (1207) will need a hole at center of head jamb.
Gliders – Triple Sash	4" (102) from each end (Units with a frame height larger than 29 1/2" (749) need additional hole at center.)	2 holes spaced 14 9/16" (370) from center.
Double Hung/ Single Hung	4"(102) from each end (Units with a frame height larger than 29 1/2" (749) need additional jamb hole placed 1 1/2" (38) above check rail on each jamb.)	N/A

Note: Swinging Window Picture and Transom, Casement/Awning and Round Top information is on page 2.

Drilling Holes

- Using the chart above for proper hole placement, mark lightly on the jamb where each hole should be placed.
NOTE: You may need to remove your sash stop.
- Place the jig on the frame at marked locations shown. Use the 3/16" bit to drill through both walls of Ultrex.
- Use the 11/32" drill bit to drill through only the **interior wall of Ultrex**.

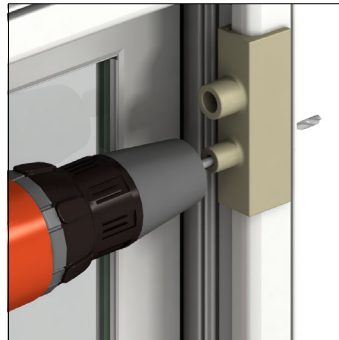
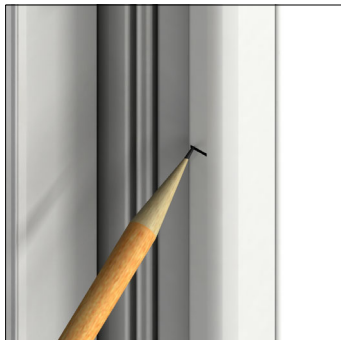

Modifying Jig for Direct Glaze Polygon and Round Top Units

- Before using the drilling jig on direct glaze units, cut off the small return leg on the jig with a sharp utility knife.

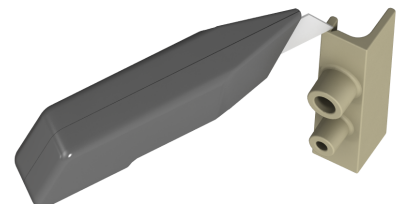

Hole Spacing Chart

Use this chart as a reference for proper installation hole spacing.

Product	Jamb Spacing	Head Jamb Spacing
Casement, Awning, Swinging Window Pictures and Transoms	4" (102) from each end. Additional holes evenly spaced along jamb, not to exceed 31 3/4" (806) between holes. See illustration for screw placement.	4" (102) from each end. Additional holes evenly spaced along head jamb, not to exceed 32" (813) between holes. Center holes in screen channel.

Drilling Holes – Head Jamb

1. Mark hole locations in screen channel using spacing chart above. Carefully drill marked holes through screen channel using a 3/16" drill bit.
2. Install unit following supplied installation instructions. When unit is properly installed, apply #8 x 3" Phillips pan head screws through screen channel into framing at drilled locations. See figure 1.

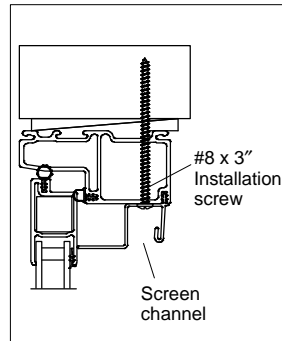

Figure 1

Drilling Holes – Jamb

1. Mark hole locations in side jamb using spacing chart above. See figure 2. Carefully drill marked holes through the screen channel and jamb cavity using a 3/16" drill bit.
2. Enlarge the 3/16" screen channel hole by using a 3/8" drill bit to carefully drill through the interior wall of the screen channel **only**. The jamb cavity hole is not enlarged. See figure 2.
3. Install unit following supplied installation instructions. When unit is properly installed, apply #8 x 3" Phillips pan head screws through side jamb into framing at drilled locations. See figure 2.

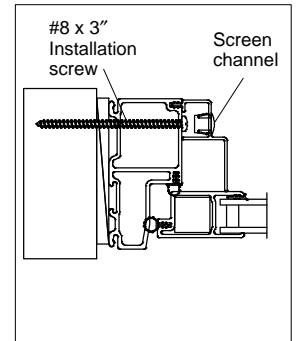

Figure 2

Hole Spacing Chart

Use this chart as a reference for proper installation hole spacing.

Product	Head Jamb Spacing
Round Top Units	4" (102) up from each end and two screws 4" (102) apart at the apex. On units over RO 54" (1372) place screws at each quarter point. See illustration 3A for screw placement.

Drilling Holes – Round Top

1. Mark hole locations on the interior edge of the unit. Place the small hole in the jig over the mark and drill a 3/16" hole through the frame of the round top unit. See figure 3A.
2. Place the large hole in the jig directly over the 3/16" hole and drill a 11/32" hole through the first layer only. See figure 3A.
3. Install unit following supplied installation instructions. When unit is properly installed, apply #8 x 3" Phillips pan head screws through head jamb into the framing at drilled locations. See figure 3B.

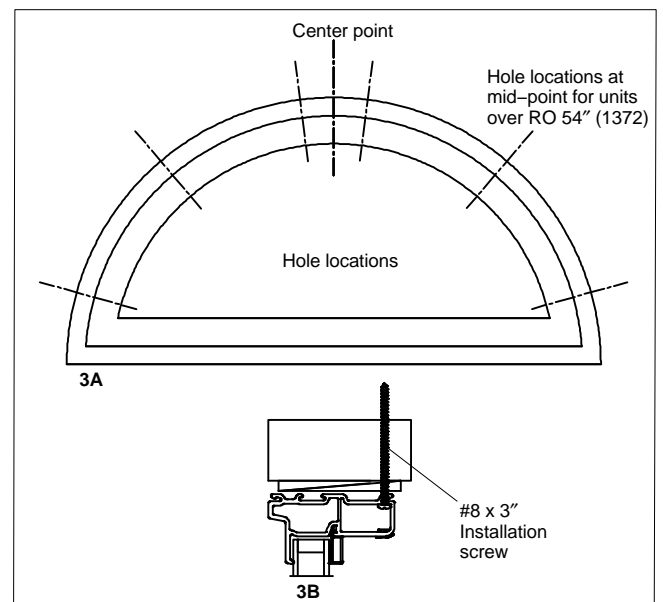

Figure 3